

KENWOOD
HI/FI STEREO COMPONENTS

SERVICE MANUAL

**KD-2070
(KD-2077)**

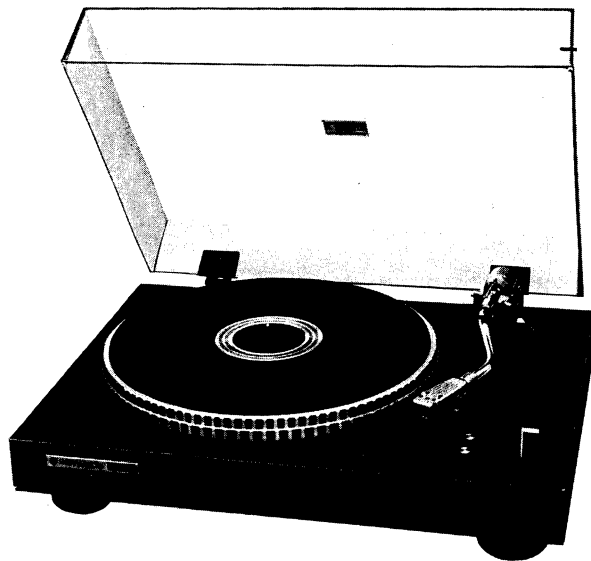

STEREO TURNTABLE

EXTERNAL VIEW

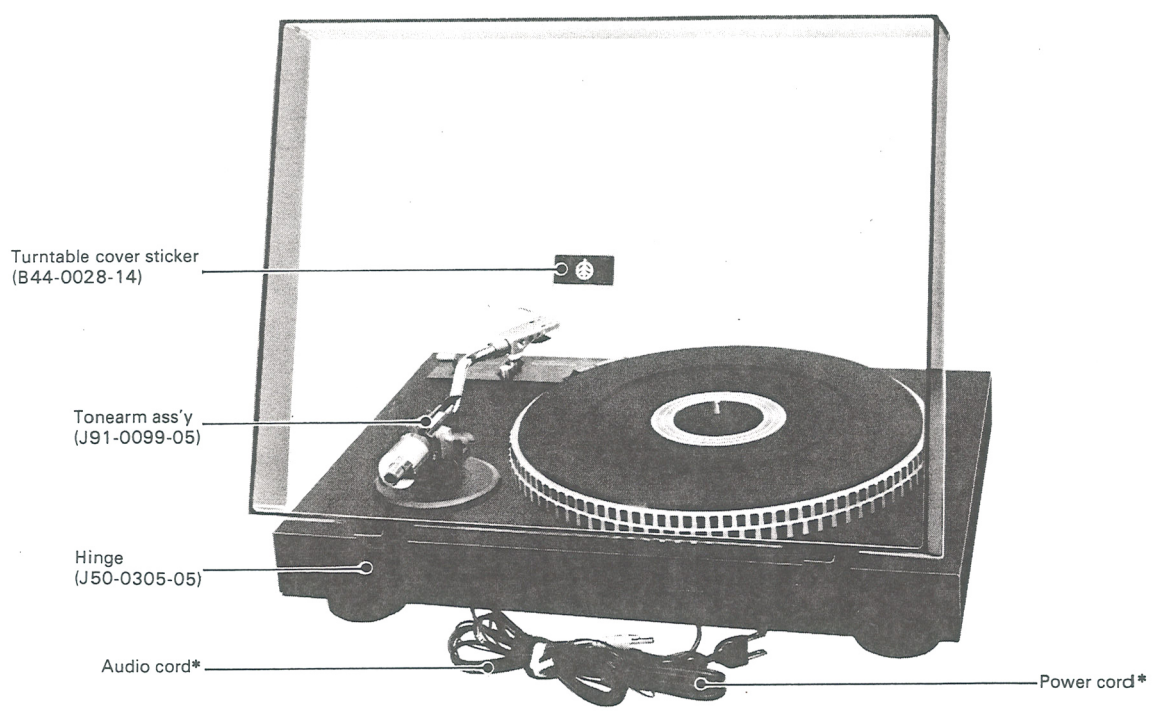
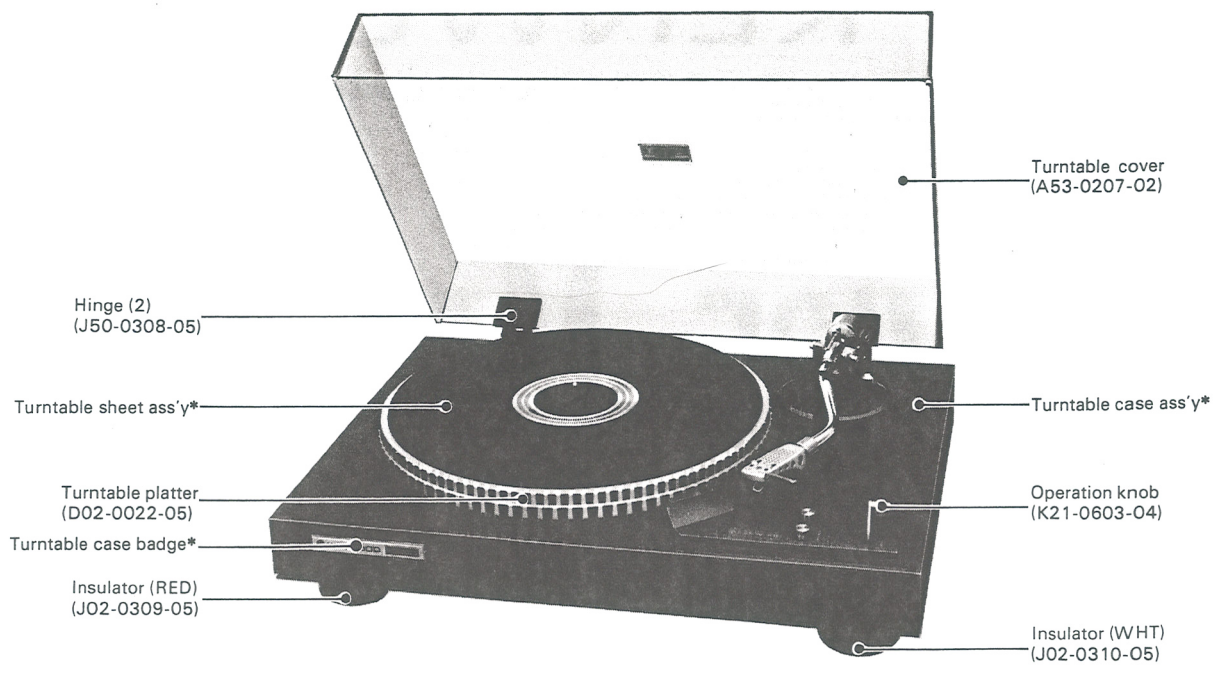

* Refer to Destinations' Parts List.

INTERNAL VIEW

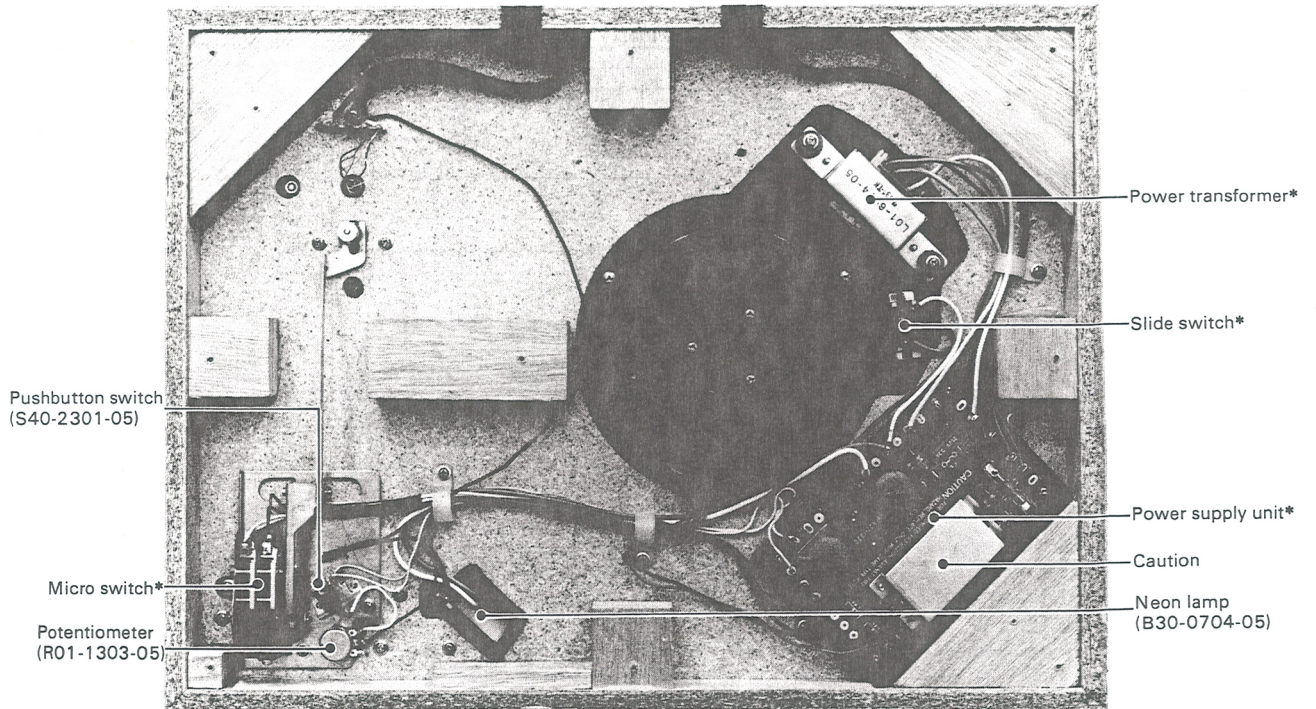
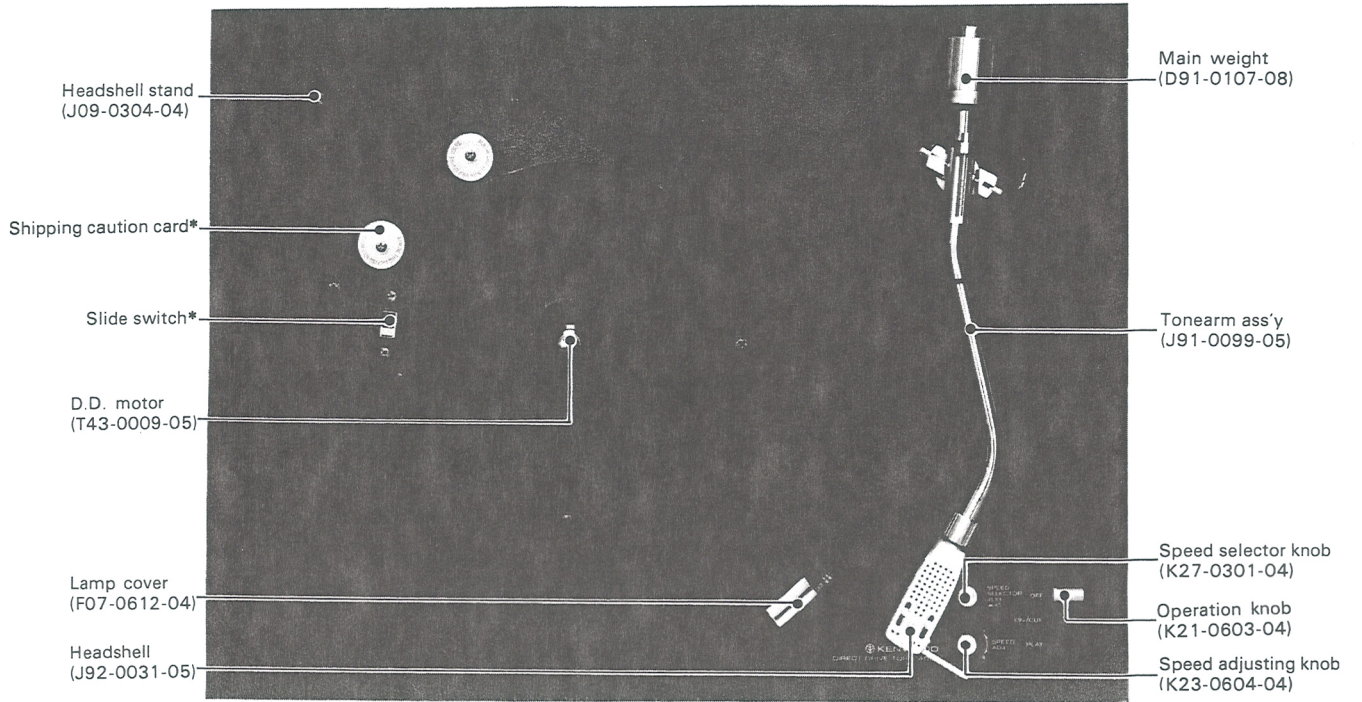

CAUTION: When the power switch is on the power voltage will be present at the heat sink. * Refer to Destinations' Parts List. Be careful that you don't touch and short-circuit the heat sink.

REPAIR/MECHANISM OPERATION/ADJUSTMENT

REPAIR

Insulator

KD-2070 employs 2 kinds of insulators, which have 2 colors as below figure; white and red.

When mounting the white insulator, should make it at the right-front on the bottom board.

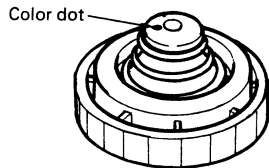

FUNCTIONS OF ELEVATION MECHANISM

OPERATING LEVER (Fig 1; overleaf)

1. When the power is in its OFF position, the operating lever is locked in the "b1" position. While the spring A is compressed and the spring B is set in free state; the elevation shaft is raised by the pressure of the spring A.
2. When the operating lever is in its ON/CUE position, the operating cam is locked in the "b2" position where the spring A remains compressed, though it is slightly loosened. The spring B is also compressed but the tension of this spring is smaller than that of the spring A. The elevation shaft remains raised.
3. When the operating lever is in its PLAY position, the operating cam is locked in the "b3" position while the spring A is set in free state and the spring B remains compressed where the elevation shaft is lowered.

From CUE position to PLAY position, the tension of the spring A and spring B are changed. Accordingly, the shaft moves up and down at optimum speed with the damping action of the silicone oil (#100,000) contained in it, regardless of the speed of the operating lever.

ADJUSTMENTS

Elevation Speed

This adjustment is made with the elevation bar setting nut. The DOWN speed of the shaft becomes faster as the setting position of the adjusting nut is turned to clockwise.

Note: After the adjustment, be sure to check the UP speed.

TURNTABLE SPEED

The turntable speed can be adjusted by the knob of the operation panel ass'y which is on the right-bottom of the turntable base. If not, turn the knob to its mechanical center position and turn the PC trimmer potentiometer of DD motor. As the bottom board has 2 holes for adjusting the turntable speed, it can be adjust without removing the bottom board.

Note: When DD motor is defective, don't disassemble and replace with new one even if schematic is drawn as below.

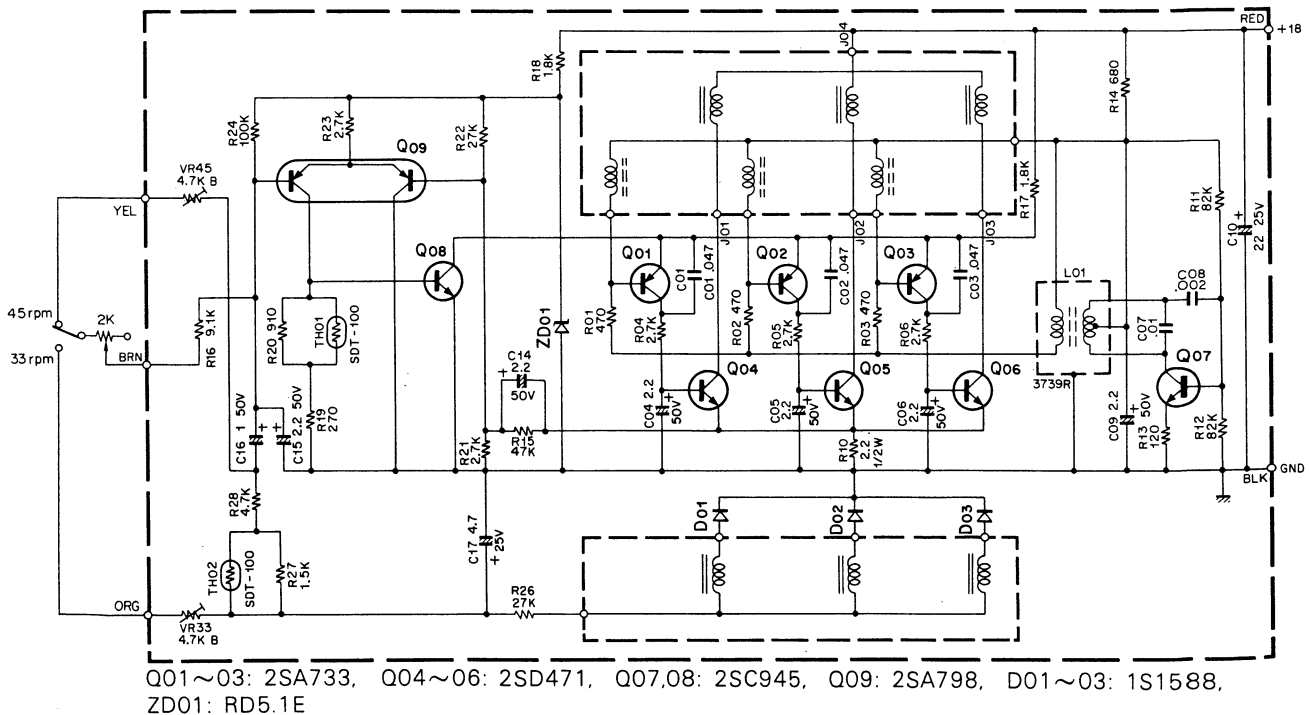

Q01~03: 2SA733, Q04~06: 2SD471, Q07,08: 2SC945, Q09: 2SA798, D01~03: 1S1588, ZD01: RD5.1E

< SCHEMATIC FOR DD MOTOR >

ADJUSTMENT/PACKING

ADJUSTMENT

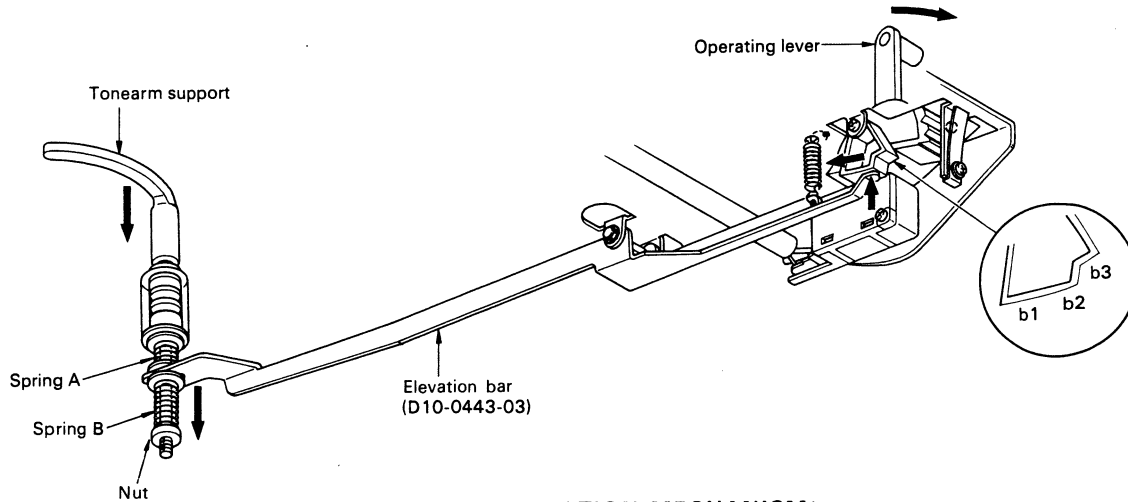

< Fig 1 ELEVATION MECHANISM >

PACKING

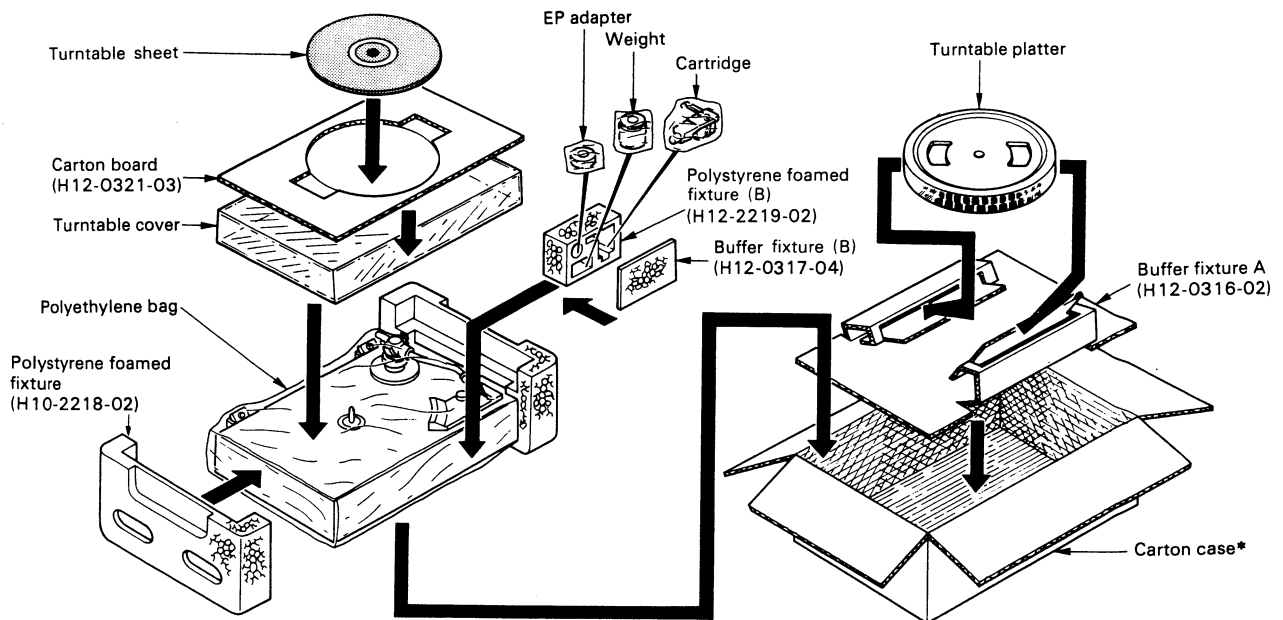

* Refer to Destinations' Parts List

EXPLODED VIEW

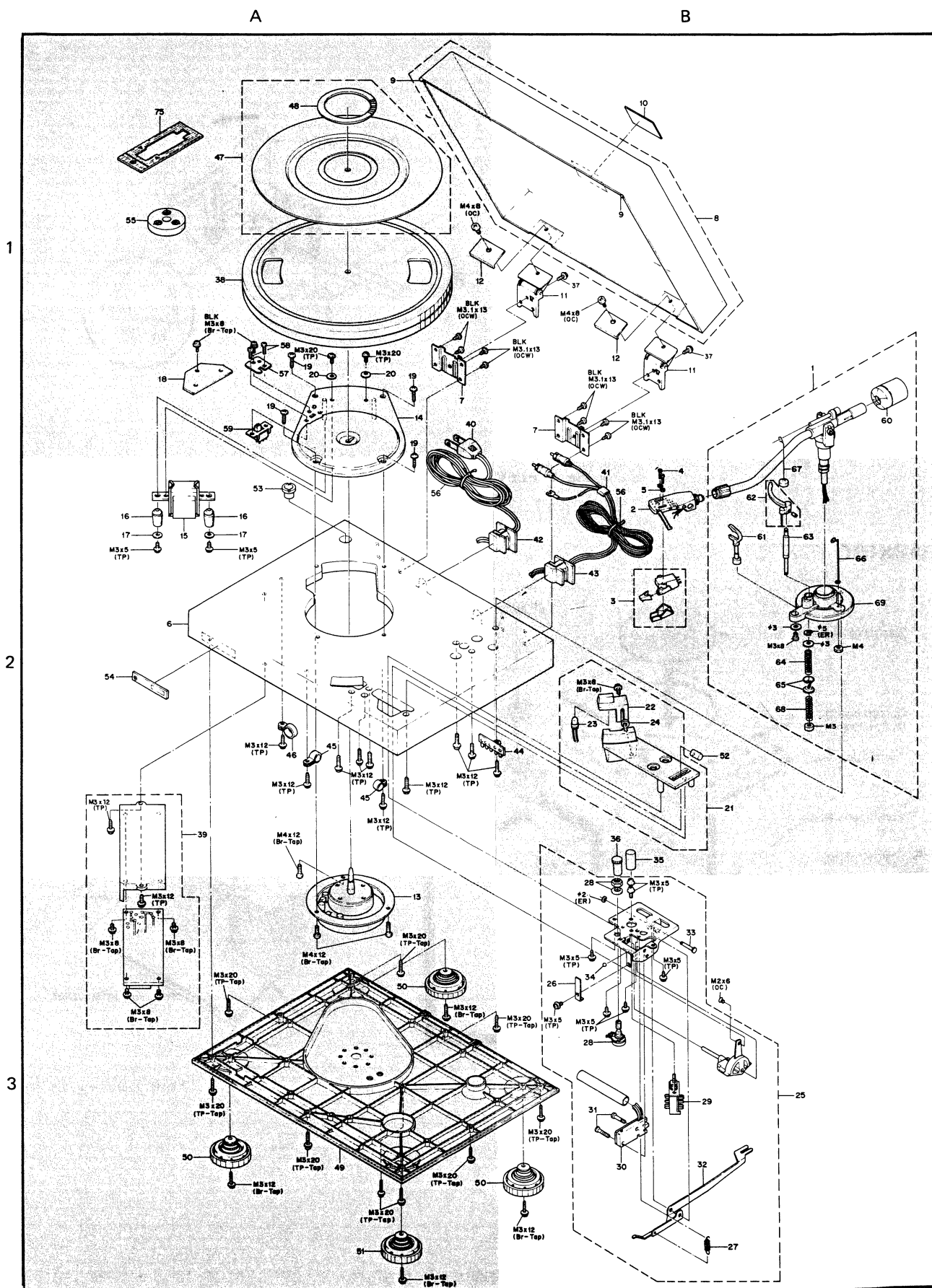

EXPLODED VIEW PARTS LIST

☆: New Parts ★: See Destinations' Parts List (overleaf)

Fig. No.	Parts No.	Description	Remarks
1	J91-0099-05	Tonearm ass'y	☆ 1B
2	J92-0031-05	Headshell	☆ 2B
3	★	Cartridge	☆ 2B
4	★	Cartridge mounting screw	☆ 2B
5	★	Washer	☆ 2B
6	★	Turntable case ass'y	☆ 2A
7	J50-0305-05	Hinge	☆ 1A,1B
8	A53-0207-02	Turntable cover	☆ 1B
9	G13-0405-04	Cushion	1A,1B
10	B44-0028-14	Turntable cover sticker	☆ 1B
11	J50-0307-05	Hinge (1)	☆ 1B
12	J50-0308-05	Hinge (2)	☆ 1A,1B
13	T43-0009-05	DD motor	☆ 3A
14	F07-0608-05	Motor cover	☆ 1A
15	★	Power Transformer	☆ 2A
16	G13-0069-04	Rubber cushion	2A
17	N19-0186-14	Washer (φ12 × φ3.3 × t1)	2A
18	★	Hole cover plate	☆ 1A
19	N09-0574-04	Flat head tapping screw	☆ 1A
20	★	Shipping caution card	1A
21	★	Operation panel ass'y	☆ 2B
22	F07-0612-04	Lamp cover	☆ 2B
23	B30-0704-05	Neon lamp	☆ 2B
24	E23-0083-05	Lug	2B
25	★	Operation mechanism ass'y	☆ 3B
26	G02-0303-04	Leaf spring	☆ 3B
27	G01-0618-04	Tension spring	☆ 3B
28	R01-1303-05	Potentiometer 2 kΩ	☆ 3B
29	S40-2301-05	Pushbutton switch	☆ 3B
30	★	Micro switch	☆ 3B
31	N09-0275-04	Polycarbonate screw (M3 × 25)	3B
32	D10-0443-03	Elevation bar	☆ 3B
33	D21-0614-04	Elevation bar shaft	☆ 3B
34	D90-0001-04	Steel ball (φ3.9688)	3B
35	K27-0301-04	Speed selector knob	☆ 2B
36	K23-0604-04	Speed adjusting knob	☆ 2B
37	N08-0402-05	Dress screw	☆ 1B
38	D02-0022-05	Turntable platter	☆ 1A
39	★	Power supply unit	☆ 2A
40	★	Power cord	1A
41	★	Audio cord	2B
42	J42-0304-05	Cord bushing (A)	☆ 2B
43	★	Cord bushing (B)	☆ 2B
44	E22-0416-05	Lug type terminal strips	2B
45	J61-0301-05	Nylon cable cramps (NK-6N)	2A
46	J61-0059-05	Nylon cable cramps (NK-10N)	2A
47	★	Turntable sheet ass'y	☆ 1A
48	D09-0202-04	Strobo scope	☆ 1A
49	A40-0512-02	Bottom board	☆ 3A
50	J02-0309-05	Insulator ass'y (red)	☆ 3A
51	J02-0310-05	Insulator ass'y (white)	☆ 3A
52	K21-0603-04	Operation knob	☆ 2B
53	J09-0304-04	Headshell stand	2A
54	★	Turntable case badge	☆ 2A
55	W01-0057-14	EP adapter	1A
56	J61-0054-05	Vinyl tie (white)	2A,2B
57	★	Switch stopper	1A

Fig. No.	Parts No.	Description	Remarks
58	★	Polycarbonate screw	1A
59	★	Slide switch (power voltage selector)	1A
60	D91-0107-08	Main weight ass'y	☆ 1B
61	D39-0066-08	Tonearm rest	☆ 2B
62	D39-0064-08	Tonearm support ass'y	☆ 2B
63	D21-0616-08	Elevation shaft	☆ 2B
64	G01-0617-08	Compression spring	☆ 2B
65	N19-0273-18	Washer	2B
66	J19-1219-08	Inside force canceller stand	☆ 2B
67	D91-0108-08	Canceller weight ass'y	☆ 2B
68	G01-0625-08	Compression spring	☆ 2B
69	J19-1245-08	Tonearm base	☆ 2B
70	B23-0004-04	Over-hang gage	1A

Power Supply (X27-1220-01)

Ref. No.	Parts No.	Description	Remarks
CAPACITOR			
C1, 2	★	Ceramic	
C3, 4	CE02W1E331	Electrolytic 330μF 25WV	☆
C5	CE04W1E470	Electrolytic 47μF 25WV	
C6	CE04W1E100	Electrolytic 10μF 25WV	
RESISTOR			
R1, 2	★	Carbon 12Ω ±10% 1/2W	
R4	RS14AB3A123J	Metal film 12kΩ ±5% 1W	
SEMICONDUCTOR			
Q1	V03-0343-05	Transistor 2SC1419 (C)	
Q2	V03-0293-05	Transistor 2SC945 (Q)	
D1~3	V11-0200-05	Diode V06C	
D4	V11-0308-05	Zener diode WZ-192	
MISCELLEOUS			
—	F01-0603-04	Heat sink	☆
—	J13-★	Holder socket × 2	☆

Fig. No.	Parts No.	Description	Remarks
M2 × 6 (OC)	N33-2006-41	Oval countersunk head screw	
M3 × 5 (TP)	N90-3005-46	TP screw	
M3 × 8	N30-3008-46	Pan head screw	
M3 × 8 (Br-Tap)	N87-3008-46	Brazier tap tight screw	
M3 × 8 (Br-Tap) BLK	N87-3008-47	Black brazier tap tight screw	
M3 × 12 (TP)	N90-3012-46	TP screw	
M3 × 12 (Br-Tap)	N87-3012-46	Brazier tap tight screw	
M3 × 20 (TP)	N90-3020-46	TP screw	
M3.1 × 13 (OCW) BLK	N61-3113-47	Black oval countersunk head wood screw	
M4 × 8 (OC)	N33-4008-47	Oval countersunk head screw	
M4 × 12 (Br-Tap)	N87-4012-46	Brazier tap tight screw	
M3	N10-2030-46	Nut	
M4	N10-2040-46	Nut	
φ2 (ER)	N24-3020-40	E washer	
φ3	N15-1030-46	Washer	
φ5 (ER)	N24-3050-60	E washer	

DESTINATIONS' PARTS LIST

Fig. No.	U.S.A. (K)	Canada (P)	PX (KD-2077)	Australia (X)	Europe (W)	Scandinavia (L)	England (T)	South Africa (S)	Other Area (M)	Audio Club (KD-2077)	Description
6	A03-0512-02 A21-0648-03	A03-0512-02 A21-0648-03	A03-0512-02 A21-0648-03	A03-0512-02 A21-0648-03	A03-0512-02 A21-0648-03	A03-0512-02 A21-0648-03	A03-0512-02 A21-0560-03	A03-0512-02 A21-0648-03	A03-0512-02 A21-0648-03	A03-0518-02 A21-0648-03	Turntable case ass'y ☆ Operation panel ass'y ☆
54	B43-0517-03 B46-0061-10	B43-0517-03 B46-0055-20	B43-0517-03 B46-0062-10	B43-0517-03 B46-0062-10	B43-0517-03 B46-0062-10	B43-0517-03 B46-0062-10	B43-0520-03 B46-0060-00	B43-0517-03 B46-0062-10	B43-0517-03 B46-0062-10	B43-0521-03 B46-0051-00 B46-0062-10	Turntable case badge ☆ Warranty card Warranty card
—	B50-2238-00	B50-2241-00	B50-2238-00	B50-2238-00	B50-2238-00	B50-2238-00	B50-2242-00	B50-2238-00	B50-2238-00	B50-2260-00	Instruction manual ☆
—	B59-0020-04	B59-0301-04	B59-0020-04	B59-0020-04	B59-0020-04	B59-0020-04	B59-0020-04	B59-0020-04	B59-0020-04	B59-0018-00 B59-0020-04	KENWOOD service stations' list Shipping caution card
C1 C1,2	C91-0302-05	C91-0024-05	—	—	—	—	—	—	—	—	Ceramic 0.047μF AC 125V Ceramic 0.01μF 2KV
57	—	—	C91-0309-05	C91-0309-05	C91-0309-05	C91-0309-05	—	C91-0309-05	C91-0309-05	C91-0309-05	Ceramic 0.047μF 1kV ☆
25	D40-0421-02	D40-0421-02	D40-0421-02	D40-0421-02	D40-0425-02	D40-0425-02	D40-0425-02	D40-0421-02	D40-0421-02	D40-0421-02	Switch stopper Operation mechanism ass'y
40	E30-0181-05	E30-0181-05	E30-0185-05	E30-0185-05	E30-0459-05	E30-0459-05	E30-0587-05	E30-0587-05	E30-1317-05	E30-1317-05	Power cord
41	E30-1309-15	E30-1318-05	E30-1318-05	E30-1318-05	E30-1318-05	E30-1318-05	E30-1318-05	E30-1318-05	E30-1318-05	E30-1318-05	Audio cord
18	F07-0610-04	F07-0610-04	F07-0610-04	F07-0610-04	F07-0610-04	F07-0610-04	F07-0610-04	F07-0610-04	F07-0610-04	F07-0610-04	Hole cover plate ☆
F1 F2	F05-3011-05	F05-3011-05	F05-8015-05	F05-8015-05	F05-8012-05	F05-8012-05	F05-8021-05	F05-8015-05	F05-8015-05	F05-8015-05	Fuse (800mA) Fuse (300mA)
47	G16-0308-03	G16-0312-03	G16-0312-03	G16-0312-03	G16-0312-03	G16-0312-03	G16-0312-03	G16-0312-03	G16-0312-03	G16-0312-03	Turntable sheet ass'y ☆
—	H01-2241-04	H01-2243-04	H01-2244-04	H01-2241-04	H01-2241-04	H01-2241-04	H01-2242-04	H01-2241-04	H01-2241-04	H01-2244-04	Carton case ☆
—	J13-0050-05	J13-0050-05	J13-0052-05	J13-0052-05	J13-0052-05	J13-0052-05	J13-0052-05	J13-0052-05	J13-0052-05	J13-0052-05	Holder socket x 2
43	J42-0305-05	J42-0305-05	J42-0305-05	J42-0305-05	J42-0305-05	J42-0305-05	J42-0305-05	J42-0305-05	J42-0305-05	J42-0305-05	Cord bushing (B) ☆
2	—	J92-0031-05	J92-0031-05	J92-0031-05	J92-0031-05	J92-0031-05	—	J92-0031-05	J92-0031-05	J92-0031-05	Headshell ☆
15	L01-6071-05	L01-6071-05	L01-6074-05	L01-6074-05	L01-6074-05	L01-6074-05	L01-6074-05	L01-6074-05	L01-6074-05	L01-6074-05	Power transformer ☆
58	—	—	N09-0078-05	—	N09-0078-05	N09-0078-05	—	N09-0078-05	N09-0078-05	N09-0078-05	Polycarbonate screw x 2
4	N09-0594-08	N09-0592-05	N09-0265-05	N09-0592-05	N09-0592-05	N09-0592-05	N09-0593-08	N09-0592-05	N09-0592-05	N09-0592-05	Cartridge mounting screw
—	N14-0405-05	N14-0108-05	—	—	—	—	N09-0594-08	—	—	—	Cartridge mounting screw
5	N19-0227-08	N19-0516-05	—	—	—	—	N14-0405-05 N19-0227-08	—	—	—	Cartridge mounting nut Cartridge mounting washer
R1	RC05GF2H-120K	RC05GF2H-120K	RC05GF2H-120K	RC05GF2H-120K	RC05GF2H-120K	RC05GF2H-120K	RC05GF2H-120K	RC05GF2H-120K	RC05GF2H-120K	RC05GF2H-120K	Carbon resistor, 120 ± 10% 1/2W
R2	—	—	—	—	RC05GF2H-120K	RC05GF2H-120K	—	RC05GF2H-120K	RC05GF2H-120K	RC05GF2H-120K	Carbon resistor, 120 ± 10% 1/2W
30	S50-1304-05	S50-1304-05	S50-1304-05	S50-1304-05	S50-1304-05 x 2	S50-1304-05 x 2	S50-1304-05	S50-1304-05	S50-1304-05	S50-1304-05	Micro switch
59	—	—	S31-2001-05	—	S31-2001-05	S31-2001-05	—	S31-2001-05	S31-2001-05	S31-2001-05	Slide switch (Power voltage selector)
3	—	T21-0062-05	T21-0061-05	T21-0061-05	T21-0061-05	T21-0061-05	—	T21-0061-05	T21-0061-05	T21-0061-05	Cartridge ☆
39	X27-1220-01	X27-1220-05	X27-1220-04	X27-1220-04	X27-1220-03	X27-1220-03	X27-1220-02	X27-1220-04	X27-1220-04	X27-1220-04	Power supply unit ☆

SCHEMATIC DIAGRAM

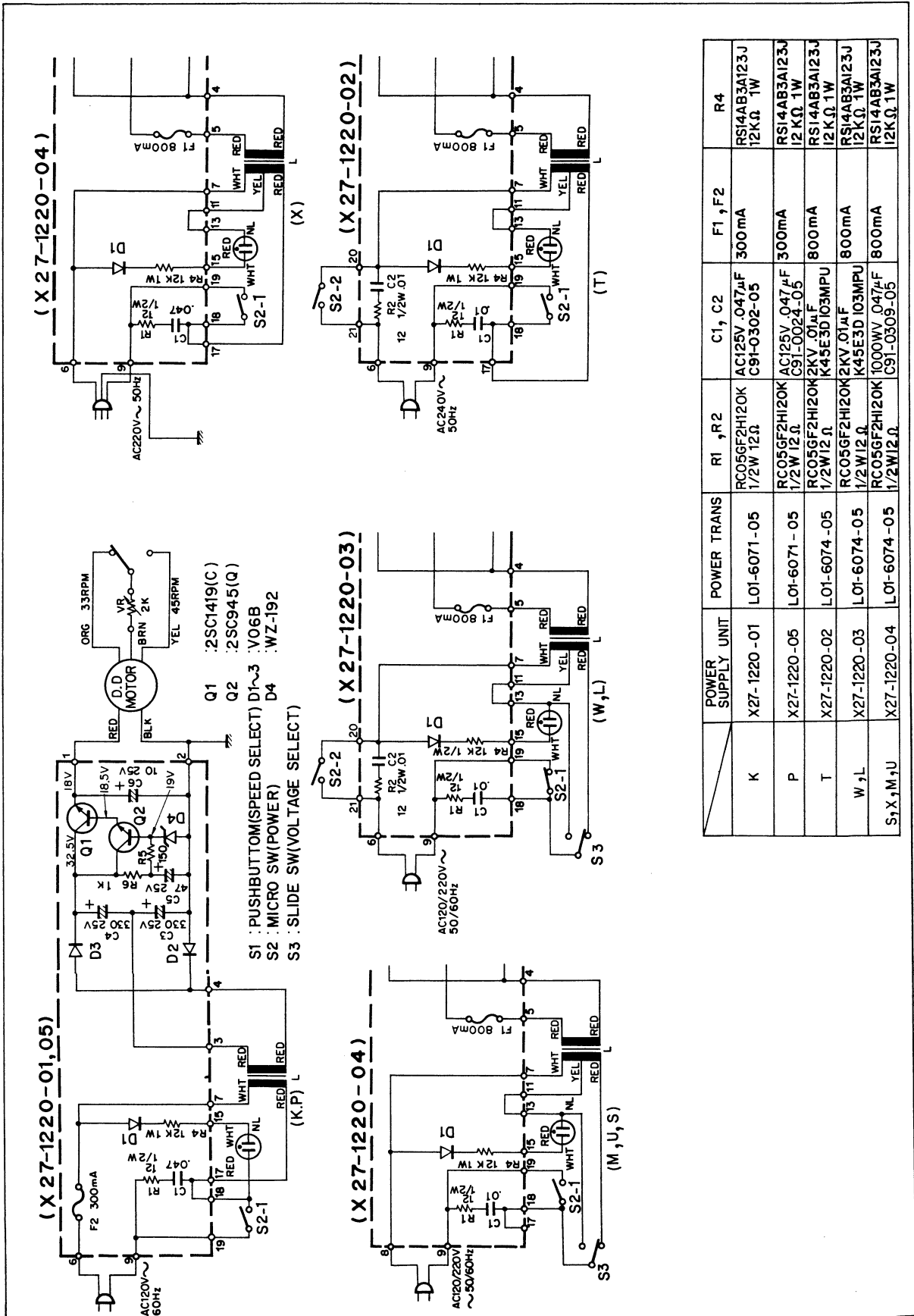

SPECIFICATIONS

MOTOR AND TURNTABLE

Drive System	Direct drive system
Motor	20-pole 30-slot D.C. servo motor
Turntable Platter	31 cm (12-3/16") diameter Aluminum Alloy Die-Cast Weight 1.1 kg (2.4 lbs)
Speeds	2 speeds, 33-1/3 and 45 rpm
Speeds Control Range	Within $\pm 3\%$
Wow and Flutter	Less than 0.04% (WRMS)
Rumble: (DIN weighted) (DIN unweighted)	Better than -65 dB Better than -45 dB

TONARM

Type	Static-balance type, S-shaped pipe arm
Effective Tonearm Length	225 mm (8-7/8")
Overhang	15 mm (9/16")
Tracking Error	± 1.5 degree
Stylus Pressure Variable Range	0 to 3 grams
Usable Cartridge Weight	4 to 10 grams

CARTRIDGE

Furnished Cartridge	V-47 (Moving Magnet type) (Certain destination models are not equipped with the V-47 cartridge.)
Stylus	N-47 with 0.5 mil Diamond
Frequency Response	20 Hz to 20,000 Hz
Output Voltage	2.0 mV (1,000 Hz, 5 cm/sec.)
Optimum Tracking Force	2.0 \pm 0.5 grams

Load Impedance	50k ohms
Replacement Stylus	N-47

ADDITIONAL FEATURES

Viscous-damped cueing device.
Anti-skating device.
Stroboscope with lamp.
Fine speed adjusting controls.
Head shell stand.
Free-stop action dust cover

MISCELLANEOUS

Power Requirement	AC 120V, 60 Hz — USA and Canada Model AC 240V, 50 Hz — U.K. Model AC 220V, 50 Hz — Australia Model AC 120/220V, 50/60 Hz (Switchable — other countries)
Power Consumption	7.0 watts
Dimensions	W 468 mm (18-7/16") H 147 mm (5-3/4") D 365 mm (14-3/8")
Weight	7.0 kg (15.4 lbs)
Accessories	EP adapter, overhang gauge

Note: Kenwood follows a policy of continuous advancements in development. For this reason specifications may be changed without notice.

KENWOOD ELECTRONICS, INC.

- 15777 SOUTH BROADWAY, GARDENA, CALIFORNIA 90248 U.S.A.
- 75 SEAVIEW DRIVE SECAUCUS, NEW JERSEY 07094 U.S.A.

TRIO-KENWOOD ELECTRONICS N.V.

- LEUVENSESTEENWEG 184, B-1930 ZAVENTEM, BELGIUM.

TRIO-KENWOOD ELECTRONICS GmbH.

- 6056 HEUSENSTAMM, RUDOLF-BRAAS-STR. 20, WEST GERMANY.

TRIO-KENWOOD FRANCE S.A.

- 15, RUE PAUL BERT, 94200 IVRY-SUR-SEINE, PARIS, FRANCE.

TRIO-KENWOOD CORPORATION

- 3-6-17 AOBADAI, MEGURO-KU, TOKYO, JAPAN.