

Pioneer

Service Manual

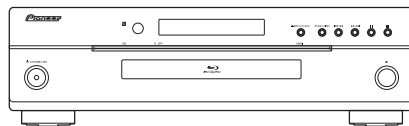

BDP-51FD

ORDER NO.
RRV3874

Blu-ray Disc PLAYER

BDP-51FD

THIS MANUAL IS APPLICABLE TO THE FOLLOWING MODEL(S) AND TYPE(S).

Model	Type	Power Requirement	DVD Region No.	BD Region No.	Remarks
BDP-51FD	WYXJ5	AC 220 V to 240 V	2	B	
BDP-51FD	WVXJ5	AC 220 V to 240 V	2	B	
BDP-51FD	WSXJ5	AC 220 V to 240 V	5	C	
BDP-51FD	TLXJ	AC 110 V to 240 V	3	A	
BDP-51FD	WPWXJ	AC 220 V to 240 V	4	B	



For details, refer to "Important Check Points for good servicing".

PIONEER CORPORATION 4-1, Meguro 1-chome, Meguro-ku, Tokyo 153-8654, Japan
PIONEER ELECTRONICS (USA) INC. P.O. Box 1760, Long Beach, CA 90801-1760, U.S.A.
PIONEER EUROPE NV Haven 1087, Keetberglaan 1, 9120 Melsele, Belgium
PIONEER ELECTRONICS ASIACENTRE PTE. LTD. 253 Alexandra Road, #04-01, Singapore 159936

©PIONEER CORPORATION 2008

T-ZZY-001 SEPT. 2008 Printed in Japan

SAFETY INFORMATION



This service manual is intended for qualified service technicians; it is not meant for the casual do-it-yourselfer. Qualified technicians have the necessary test equipment and tools, and have been trained to properly and safely repair complex products such as those covered by this manual. Improperly performed repairs can adversely affect the safety and reliability of the product and may void the warranty. If you are not qualified to perform the repair of this product properly and safely, you should not risk trying to do so and refer the repair to a qualified service technician.



WARNING!

THE LASER COMPONENT IS CAPABLE OF EMITTING RADIATION EXCEEDING THE LIMIT FOR CLASS 1.
A SPECIALLY INSTRUCTED PERSON SHOULD DO SERVICING OPERATION OF THE APPARATUS.

Laser Pickup specifications and Laser characteristics

For BD	Wave length : 405 nm Operating output : 0.95 mW CW, Class 1M Maximum output : Class 2 (under fault condition)
For DVD	Wave length : 660nm Operating output : 1.06 mW CW, Class 1M Maximum output : Class 2M (under fault condition)
For CD	Wave length : 785 nm Operating output : 1.34 mW CW, Class 1M Maximum output : Class 1M (under fault condition)

LABEL CHECK

The following caution label appears on your unit.
Location: inside of the unit

CAUTION CLASS 3B VISIBLE AND INVISIBLE LASER RADIATION
WHEN OPEN, AVOID EXPOSURE TO THE BEAM.
ATTENTION RADIATIONS LASER VISIBLES ET INVISIBLES DE CLASSE 3B
QUAND OUVERT, EVITEZ TOUT EXPOSITION AU FAISCEAU.
ADVARSEL KLASSE 3B SYNLIG OG USYNLIG LASERSTRÅLING VED ÅBNING.
UNDGÅ UDSÆTTELSE FOR STRÅLING.
VARNING KLASSE 3B SYNLIG OCH USYNLIG LASERSTRÅLNING NÄR DENNA
DEL ÄR ÖPPNAD. UNDVIK ATT UTSÄTTA DIG FÖR STRÅLEN.
VORSICHT BEI GEÖFFNETER ABDECKUNG IST SICHTBARE UND UNSICHTBARE
LASERSTRAHLUNG DER KLASSE 3B IM GERÄTENNEREN
VORHANDEN. NICHT DEM LASERSTRAHL AUSSETZEN!
PRECAUCIÓN CUANDO SE ABRE HAY RADIACIÓN LÁSER DE CLASE 3B VISIBLE
E INVISIBLE. EVITE LA EXPOSICIÓN A LOS RAYOS LÁSER.
VARO! AVATTAESSÄ OLET ALTTIINA NÄKYVÄLLÄ JA
NÄKYMÄTTÖMÄLLÄ LUOKAN 3B LASERSATELYLLE.
ÄLÄ KATSO SÄTEESEEN.
注意 ここを開くと CLASS 3B の可視レーザー光及び不可視レーザー
光が出ます。ビームを直接見たり、触れたりしないこと。

DRW2282 - A

For TLXJ

注意：打開時會有CLASS 3B可見和不可見
鐳射輻射、請勿受鐳射束輻射。

VRW2383

(Printed on the Rear Panel)

CLASS 1
LASER PRODUCT

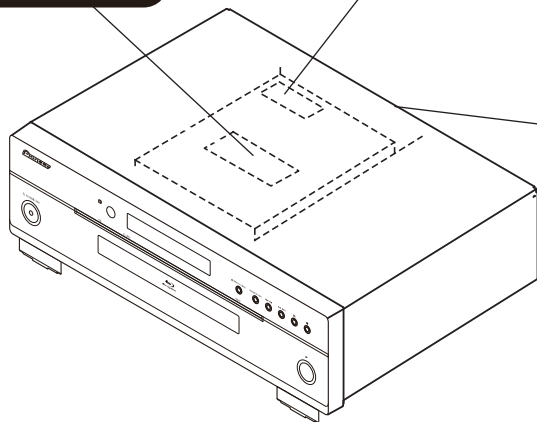

BDP-51FD

[Important Check Points for Good Servicing]

In this manual, procedures that must be performed during repairs are marked with the below symbol. Please be sure to confirm and follow these procedures.

1. Product safety



Please conform to product regulations (such as safety and radiation regulations), and maintain a safe servicing environment by following the safety instructions described in this manual.

- ① Use specified parts for repair.

Use genuine parts. Be sure to use important parts for safety.

- ② Do not perform modifications without proper instructions.

Please follow the specified safety methods when modification (addition/change of parts) is required due to interferences such as radio/TV interference and foreign noise.

- ③ Make sure the soldering of repaired locations is properly performed.

When you solder while repairing, please be sure that there are no cold solder and other debris. Soldering should be finished with the proper quantity. (Refer to the example)

- ④ Make sure the screws are tightly fastened.

Please be sure that all screws are fastened, and that there are no loose screws.

- ⑤ Make sure each connectors are correctly inserted.

Please be sure that all connectors are inserted, and that there are no imperfect insertion.

- ⑥ Make sure the wiring cables are set to their original state.

Please replace the wiring and cables to the original state after repairs. In addition, be sure that there are no pinched wires, etc.

- ⑦ Make sure screws and soldering scraps do not remain inside the product.

Please check that neither solder debris nor screws remain inside the product.

- ⑧ There should be no semi-broken wires, scratches, melting, etc. on the coating of the power cord.

Damaged power cords may lead to fire accidents, so please be sure that there are no damages. If you find a damaged power cord, please exchange it with a suitable one.

- ⑨ There should be no spark traces or similar marks on the power plug.

When spark traces or similar marks are found on the power supply plug, please check the connection and advise on secure connections and suitable usage. Please exchange the power cord if necessary.

- ⑩ Safe environment should be secured during servicing.

When you perform repairs, please pay attention to static electricity, furniture, household articles, etc. in order to prevent injuries. Please pay attention to your surroundings and repair safely.

2. Adjustments



To keep the original performance of the products, optimum adjustments and confirmation of characteristics within specification. Adjustments should be performed in accordance with the procedures/instructions described in this manual.

3. Lubricants, Glues, and Replacement parts



Use grease and adhesives that are equal to the specified substance. Make sure the proper amount is applied.

4. Cleaning



For parts that require cleaning, such as optical pickups, tape deck heads, lenses and mirrors used in projection monitors, proper cleaning should be performed to restore their performances.

5. Shipping mode and Shipping screws



To protect products from damages or failures during transit, the shipping mode should be set or the shipping screws should be installed before shipment. Please be sure to follow this method especially if it is specified in this manual.

CONTENTS

	SAFETY INFORMATION	2
	1. SERVICE PRECAUTIONS	5
A	1.1 NOTES ON SOLDERING	5
	2. SPECIFICATIONS	6
	2.1 ACCESSORIES	6
	2.2 SPECIFICATIONS.....	7
	2.3 DISC/CONTENT FORMAT	8
	2.4 PANEL FACILITIES	12
	3. BASIC ITEMS FOR SERVICE.....	15
	3.1 CHECK POINTS AFTER SERVICING.....	15
	3.2 PCB LOCATIONS	16
	3.3 JIGS LIST	17
	4. BLOCK DIAGRAM.....	18
	4.1 OVERALL WIRING DIAGRAM.....	18
B	4.2 BLOCK DIAGRAM	20
	4.3 POWER BLOCK DIAGRAM.....	21
	5. DIAGNOSIS.....	22
	5.1 POWER ON SEQUENCE	22
	5.2 RESET ON SEQUENCE.....	23
	6. SERVICE MODE	24
	6.1 OSD	24
	7. DISASSEMBLY.....	34
	8. EACH SETTING AND ADJUSTMENT	41
	8.1 NECESSARY ADJUSTMENT POINTS	41
	8.2 MODEL SETTING.....	42
C	8.3 CPRM ID NUMBER AND DATA SETTING.....	44
	8.4 FIRMWARE UPDATE.....	46
	9. EXPLODED VIEWS AND PARTS LIST	48
	9.1 PACKING SECTION	48
	9.2 EXTERIOR SECTION.....	50
	9.3 FRONT PANEL SECTION	52
	10. SCHEMATIC DIAGRAM	54
	10.1 MAIN ASSY (1/10)(GUIDE PAGE).....	54
	10.2 MAIN ASSY (2/10)(GUIDE PAGE).....	60
	10.3 MAIN ASSY (3/10).....	66
	10.4 MAIN ASSY (4/10).....	68
	10.5 MAIN ASSY (5/10).....	70
D	10.6 MAIN ASSY (6/10).....	72
	10.7 MAIN ASSY (7/10).....	74
	10.8 MAIN ASSY (8/10).....	76
	10.9 MAIN ASSY (9/10).....	77
	10.10 MAIN ASSY (10/10)(GUIDE PAGE).....	78
	10.11 FLKY AND PSWB ASSYS.....	84
	10.12 AUJB ASSY (1/2).....	86
	10.13 AUJB ASSY (2/2).....	88
	10.14 SYPS ASSY.....	90
	10.15 WAVEFORMS.....	92
	11. PCB CONNECTION DIAGRAM	94
	11.1 MAIN ASSY	94
E	11.2 FLKY AND PSWB ASSYS.....	98
	11.3 AUJB ASSY	102
	11.4 SYPS ASSY.....	104
	12. PCB PARTS LIST	106

1. SERVICE PRECAUTIONS

1.1 NOTES ON SOLDERING

- For environmental protection, lead-free solder is used on the printed circuit boards mounted in this unit.
Be sure to use lead-free solder and a soldering iron that can meet specifications for use with lead-free solders for repairs accompanied by reworking of soldering. A
- Compared with conventional eutectic solders, lead-free solders have higher melting points, by approximately 40 °C. Therefore, for lead-free soldering, the tip temperature of a soldering iron must be set to around 373 °C in general, although the temperature depends on the heat capacity of the PC board on which reworking is required and the weight of the tip of the soldering iron.

Do NOT use a soldering iron whose tip temperature cannot be controlled.

Compared with eutectic solders, lead-free solders have higher bond strengths but slower wetting times and higher melting temperatures (hard to melt/easy to harden). B

The following lead-free solders are available as service parts:

- Parts numbers of lead-free solder:
 - GYP1006 1.0 in dia.
 - GYP1007 0.6 in dia.
 - GYP1008 0.3 in dia.

A

B

C

D

E

F

2. SPECIFICATIONS

2.1 ACCESSORIES

Remote Control
(VXX3318)

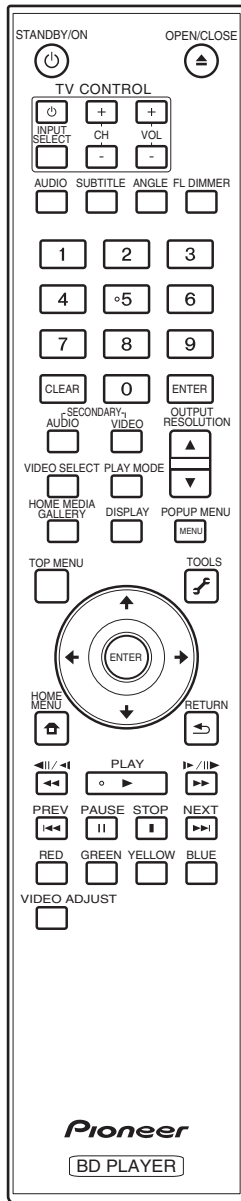

Audio Cable (white/red plugs) x 1
(XDE3045)
L=1.5m

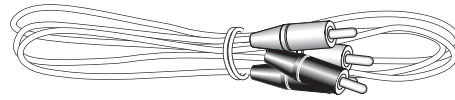

Video Cable (yellow plugs) x 1
(XDE3046)
L=1.5m

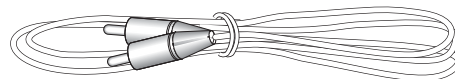

Power Cable x 1
(ADG7062 : /WYXJ5, /WSXJ5)

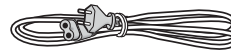

(ADG7104 : /WVXJ5, /TLXJ)

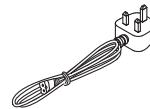

(ADG7100 : /WPWXJ)

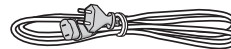

AA/R6 dry cell batteries x 2

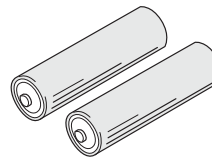

Warranty Card

Operating Instructions
(VRB1511 : /WYXJ5, /WVXJ5)
(VRB1512 : /TLXJ, /WPWXJ)
(VRC1530 : /WSXJ5 Only)
(VRC1526 : /WYXJ5 Only)
(VRC1527 : /WYXJ5 Only)
(VRC1528 : /WYXJ5 Only)
(VRC1529 : /WYXJ5 Only)
(VRC1532 : /TLXJ Only)

5

6

7

8

2.2 SPECIFICATIONS

Model		BDP-51FD
Type		Blu-ray Disc PLAYER
Rated voltage		AC 220 V to 240 V (/TLXJ only : AC 110 V to 240 V)
Rated frequency		50 Hz/60 Hz
Power consumption		34 W
Power consumption (standby)		0.5 W
Weight		5.6 kg
External dimensions (including projecting parts)		420 mm (W) x 124 mm (H) x 361 mm (D)
Tolerable operating temperature		+5 °C to +35 °C
Tolerable operating humidity		5 % to 85 % (no condensation)
Output terminals	Video outputs	
	Video	1 set, RCA jack (1.0 Vp-p (75 Ω))
	S-Video	1 set, S-Video jack: Y (luminance): 1.0 Vp-p (75 Ω) C (color): 0.300 Vp-p (75 Ω, PAL), 0.286 Vp-p (75 Ω, NTSC)
	Component video	1 set, RCA jacks: Y: 1.0 Vp-p (75 Ω) PB, PR: 0.7 Vp-p (75 Ω)
	HDMI	1 set, 19-pin (5 V, 150 mA)
Audio outputs	2-channel (stereo)	Number of channels: 2, RCA jacks
	7.1-channel (multi-channel: front left/right, surround left/right, center, surround back left/right, subwoofer)	Number of channels: 8, RCA jacks
	Audio output level	200 mVrms (1 kHz, -20 dB)
	Frequency response	4 Hz to 88 kHz (192 kHz sampling)
	S/N ratio	115 dB
	Dynamic range	103 dB
	Total harmonic distortion	0.0015 %
Wow & flutter	Below measurable limits (±0.001 % W. PEAK)	
Digital audio outputs	Optical	1 set, Optical digital jack
	Coaxial	1 set, RCA jack
Control	Input	1 set, Minijack (3.5 ø)

Note

- The specifications and design of this product are subject to change without notice.
- This product includes FontAvenue® fonts licensed by NEC Corporation. FontAvenue is a registered trademark of NEC Corporation.

BDP-51FD

5

6

7

8

7

2.3 DISC/CONTENT FORMAT

[1] Playable discs

Discs with the logo marks below indicated on the disc label, package or jacket can be played.

Disc type	Logo	Application format						
		BDMV ¹	BDAV	DVD-Video	DVD VR	CD-DA DTS-CD	DATA-DISC ²	
BD	BD-ROM		✓	✓	X	X	X	X
	BD-R		✓	✓	X	X	X	X
	BD-RE		✓	✓	X	X	X	X
DVD	DVD-ROM		✓	X	✓	X	X	✓
	DVD-R		✓	X	✓	✓	X	✓
DVD	DVD-R DL (Dual Layer)		✓	X	✓	✓	X	✓
	DVD-RW		✓	X	✓	✓	X	✓
	DVD+R		✓	X	✓	X	X	✓
	DVD+RW		✓	X	✓	X	X	✓
CD	CD-DA (Music CD)		X	X	X	X	✓	X
	CD-R		X	X	X	X	✓	✓
	CD-RW		X	X	X	X	✓	✓
	CD-ROM		X	X	X	X	✓	✓

1. Including the AVCHD format.

2. Discs on which movie files or music files are recorded

❖ Discs that cannot be played

- HD DVDs
- DVD Audio discs
- DVD-RAM discs
- Non-finalized DVD-R/DVD-RW/DVD+R/DVD+RW discs in the DVD-Video format and AVCHD format
- Non-finalized Dual Layer DVD-R discs in the DVD VR format

- SACDs
- Video CDs
- SVCDs

“Blu-ray Disc” and  are trademarks.

 is a trademark of DVD Format/Logo Licensing Corporation.



Note

- Some discs cannot be played, even if one of the above logo marks is indicated.
- To play 8 cm discs, set the disc in the 8 cm disc depression in the center of the disc tray. No adapter is necessary. 8 cm BD-ROMs cannot be played.

❖ About audio formats

The following audio formats are supported on this player:

- Dolby TrueHD
- Dolby Digital Plus
- Dolby Digital
- DTS-HD Master Audio
- DTS-HD High Resolution Audio
- DTS Digital Surround
- MPEG
- MPEG-2 AAC
- Linear PCM

To enjoy the surround sound of Dolby TrueHD, Dolby Digital Plus, DTS-HD Master Audio and DTS-HD High Resolution Audio, it is recommended to connect the player to an AV receiver or amplifier compatible with these audio formats using an HDMI cable. After loading a BD containing sound in one of these audio formats, select the audio format on the menu screen.



Manufactured under license from Dolby Laboratories. Dolby and the double-D symbol are trademarks of Dolby Laboratories.



Manufactured under license under U.S. Patent #: 5,451,942; 5,956,674; 5,974,380; 5,978,762; 6,487,535 & other U.S. and worldwide patents issued & pending. DTS is a registered trademark and the DTS logos, Symbol, DTS-HD and DTS-HD Advanced Digital Out are trademarks of DTS, Inc. © 1996-2007 DTS, Inc. All Rights Reserved.

❖ Playing BDs

- BDs (BDMV) compatible with the formats below can be played.
 - Blu-ray Disc Read-Only (ROM) Format Version 2
 - Blu-ray Disc Recordable (R) Format Version 2
 - Blu-ray Disc Rewritable (RE) Format Version 3

This player supports BD-ROM Profile 1 Version 1.1. BONUSVIEW Functions such as playback of secondary video (Picture-in-Picture) and secondary audio can be used. For details on secondary video and secondary audio playback, refer to the disc's instructions.

BONUSVIEW™

"BONUSVIEW" is trademark of Blu-ray Disc Association.

When a BD-ROM is played, additional data may be stored in the player's memory area (local storage). If the message indicating low memory (local storage) appears, erase the BDMV data.

- BDs (BD-RE) compatible with the formats below can be played.
 - Blu-ray Disc Recordable (R) Format Version 1
 - Blu-ray Disc Rewritable (RE) Format Version 2
- Dual Layer BDs can be played.
- Movie and music files recorded on BDs cannot be played.
- 8 cm BD-ROMs cannot be played.

❖ Playing DVDs

- DVD-Video can be played.
- DVD-R/-RW/+R/+RW discs recorded in the DVD-Video format can be played (finalize them before playing them on this player).
- DVD-R/-RW discs recorded in the VR format (Video Recording format) can be played.
- This label indicates playback compatibility with DVD-RW discs recorded in VR format (Video Recording format). However, for discs recorded with a record-only-once encrypted program, playback can only be achieved using a CPRM compatible device.



- DVDs recorded in the AVCHD format can be played (finalize them before playing them on this player).



"AVCHD" and the "AVCHD" logo are trademarks of Matsushita Electric Industrial Co., Ltd. and Sony Corporation.

- Movie and music files recorded on DVD-R/-RW/+R/+RW discs can be played.
- Dual Layer DVDs can be played. However, Non-finalized Dual Layer DVD-R discs recorded in the VR format cannot be played (finalize them before playing them on this player).
- HD DVD, DVD Audio and DVD-RAM discs cannot be played.

❖ About region numbers

A Blu-ray Disc Player and BD-ROM or DVD-Video discs are assigned region numbers according to the region in which they are sold.

This player's region numbers are:

- BD-ROM :
 - /WYXJ5, WVXJ5, WPWXJ : B
 - /WSXJ5 : C
 - /TLXJ : A
- DVD-Video :
 - /WYXJ5, WVXJ5 : 2
 - /WSXJ5 : 5
 - /TLXJ : 3
 - /WPWXJ : 4

B

Discs not including these numbers cannot be played. Discs playable on this player are as shown below.

- BDs:
 - /WYXJ5, WVXJ5, WPWXJ : B (including B) and ALL



- /WSXJ5 : C (including C) and ALL



- /TLXJ : A (including A) and ALL



D

- DVDs:
 - /WYXJ5, WVXJ5 : 2 (including 2) and ALL



- /WSXJ5 : 5 (including 5) and ALL



- /TLXJ : 3 (including 3) and ALL



- /WPWXJ : 4 (including 4) and ALL



F

❖ Playing CDs

- Music CDs (CD-DAs and DTS-CDs) can be played.
- Movie and music files recorded on CDs can be played. See [2] *Playable files* below.
- SACD, Video CD and Super VCD discs cannot be played.
- Regarding copy protected CDs: This player is designed to conform to the specifications of the Audio CD format. This player does not support the playback or function of discs that do not conform to these specifications.

❖ DualDisc playback

A DualDisc is a new two-sided disc, one side of which contains DVD content — video, audio, etc. — while the other side contains non-DVD content such as digital audio material.

The DVD side of a DualDisc will play on this player (excluding any DVD-Audio content).

The non-DVD, audio side of the disc is not compatible with this player.

It is possible that when loading or ejecting a DualDisc, the opposite side to that being played will be scratched. Scratched discs may not be playable.

For more detailed information on the DualDisc specification, please refer to the disc manufacturer or disc retailer.

❖ Playing discs created on computers

- It may not be possible to play DVD-R/-RW or CD-R/-RW discs recorded using a personal recorder or computer. (This can be due to various reasons, including disc properties, scratches, dirt on the disc, dirt on the player's lens, condensation and so on.)
- It may not be possible to play discs recorded using a computer due to the application settings or environment. Record discs in the proper format. For details, contact the dealer.

[2] Playable files

Movie and music files recorded on DVDs and CDs can be played.



Caution

- In DVD, only the one recorded by the ISO 9660 file system can be played.
- Some files may not be playable.
- For some files, it may not be possible to use certain functions during playback.
- It may not be possible to play some files, even if they have the extension of a file playable on this player.
- Files protected by DRM (Digital Rights Management) cannot be played (not including DivX VOD files).

❖ Supported movie file formats

• DivX

DivX is a media technology created by DivX, Inc. DivX media files contain not only video but also advanced media features like subtitles and alternate audiotracks, etc.

Conform to the size under 720 x 576 pixels/720 x 480 pixels. DivX files encoded with GMC/Qpel option cannot be played. Only audio signals with MP3 or Dolby Digital (AC3) format are output.

Note that files other than the ones containing DivX video cannot be played, even if they have the extension “.avi”.



Official DivX[®] Certified product.

Plays all versions of DivX[®] video (including DivX[®] 6) with standard playback of DivX[®] media files.

DivX, DivX Certified, and associated logos are trademarks of DivX, Inc. and are used under license.



Note

- DivX VOD files are protected by DRM. They can only be played on registered devices.
- You may be requested by the file distributor to input the DivX VOD registration code for authorization of the player in order to play DivX VOD files. This player's DivX VOD registration code can be checked at **Initial Setup → Options → DivX VOD → Registration Code**.
- DivX VOD files for which the player's DivX VOD registration code is not authorized cannot be played (**Authorization Error** is displayed).
- The number of views is restricted for some DivX VOD files. When such files are played on this player, the remaining number of views is displayed. Files for which the remaining number of views has reached 0 cannot be played (**Rental Expired** is displayed). Files for which the number of views is not restricted can be played as many times as you like (the remaining number of views is not displayed).

❖ Supported music file formats

• Windows Media™ Audio 9 (WMA9)

Bit rate: Up to 192 kbps

Sampling frequencies: 22.05 kHz, 32 kHz, 44.1 kHz and 48 kHz

Windows Media is either a registered trademark or trademark of Microsoft Corporation in the United States and/or other countries.

This product includes technology owned by Microsoft Corporation and cannot be used or distributed without a license from Microsoft Licensing, Inc.

• MPEG-1 Audio Layer 3 (MP3)

Bit rate: Up to 320 kbps

Sampling frequencies: 8 kHz, 11.025 kHz, 12 kHz, 16 kHz, 22.05 kHz, 24 kHz, 32 kHz, 44.1 kHz and 48 kHz

❖ Playable file extensions

• Movie files

.divx and .avi

• Music files

.wma and .mp3

2.4 PANEL FACILITIES

[1] Front Panel

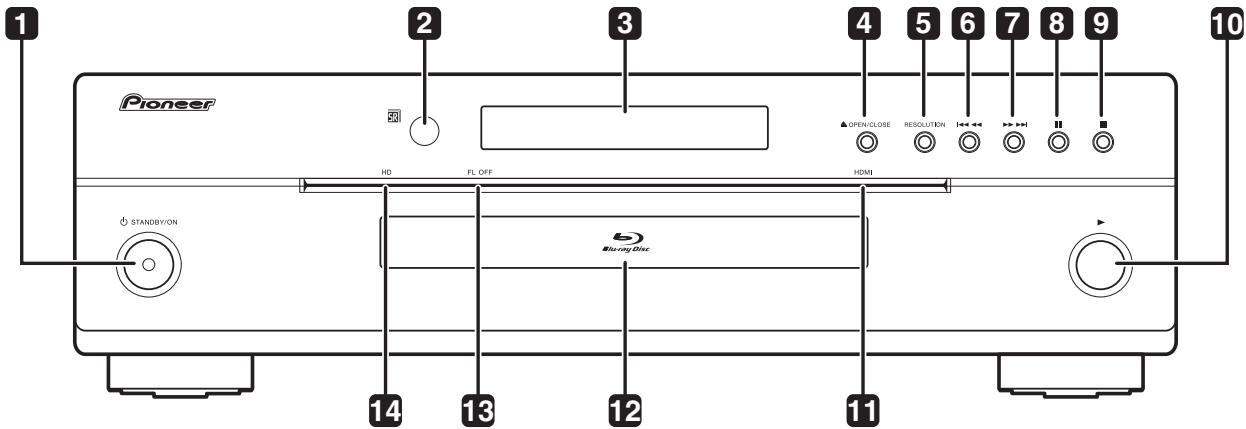

1 STANDBY/ON

Press to turn the power on and off.

2 **Remote control sensor**

Point the remote control to this, then operate it within approximately 7 m.

The player may have trouble capturing remote control signals if there is a fluorescent light nearby. If this happens, move the player away from the fluorescent light.

3 **Front panel display**

4 OPEN/CLOSE

Press to open and close the disc tray.

5 **RESOLUTION**

Press to switch the output video resolution from the **HDMI OUT** or **COMPONENT VIDEO** output terminals.

6

Press to skip to the beginning of the previous title/chapter/track/file. Press and hold to start reverse scanning.

7

Press to skip to the beginning of the next title/chapter/track/file. Press and hold to start forward scanning.

8

Press during playback to pause. Press again to restart playback.

9

Press to stop playback.

10

Press to start playback.

11 **HDMI indicator**

This lights when video signals from the **HDMI OUT** terminal is output.

12 **Disc tray**

13 **FL OFF indicator**

This lights when **Off** is selected with **FL DIMMER**

14 **HD indicator**

This lights when an HDMI cable is connected and video signals are being output with a resolution of 1080/50i, 1080/50p, 720/50p, 1080/24p, 1080/60i, 1080/60p or 720/60p. It also lights when a component video cable is connected and video signals are being output with a resolution of 1080/60i or 720/60p.

[2] Remote control unit

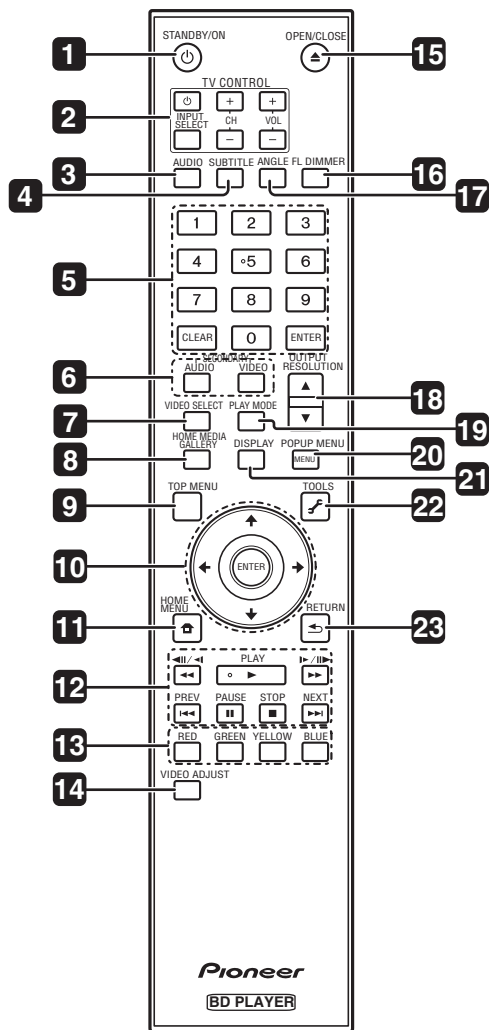

1 STANDBY/ON

Press to turn the power on and off.

2 TV CONTROL

Your TV can be controlled using the player's remote control.

- Press to turn the TV's power on and off.
- INPUT SELECT** – Press to switch the TV's input.
- CH +/-** – Press to select the TV channel.
- VOL +/-** – Press to adjust the volume.

3 AUDIO

Press to switch the audio streams/channels.

4 SUBTITLE

Press to switch the subtitles.

5 Number buttons – Use these to select and play the title/ chapter/track you want to watch or listen to and to select items from menus.

- CLEAR** – Press to clear the numeric number, etc.
- ENTER** – Press to execute the selected item or enter a setting that has been changed, etc.

6 SECONDARY AUDIO – When playing a BD-ROM on which secondary audio is recorded, press to switch to the secondary audio.

SECONDARY VIDEO – When playing a BD-ROM on which secondary video (Picture-in-Picture) is recorded, press to switch to the secondary video.

7 VIDEO SELECT

Press to switch the terminal from which the video signals are output. Use to switch between digital output (**HDMI OUT** terminal) and analog output (**COMPONENT VIDEO**, **S-VIDEO** or **VIDEO** output terminals) (**the signals are only output from the selected video output terminal**).

8 HOME MEDIA GALLERY

Press to display/hide the Home Media Gallery screen.

9 TOP MENU

Press to display the top menu of the BD-ROM or DVD-Video.

10 – Use to select items, change settings and move the cursor.

ENTER – Press to execute the selected item or enter a setting that has been changed, etc.

11 HOME MENU

Press to display/hide the Home Menu.

12 **PLAY** – Press to start playback.

II PAUSE – Press to pause playback. Press again to restart playback.

■ STOP – Press to stop playback.

◀◀ PREV/▶▶ NEXT – Press to skip to the beginning of the previous/next title/chapter/track/file.

◀◀/◀||/▶||/▶▶ – Press during playback to start reverse scanning. While playback is paused, press for step reverse playback. Press and hold while playback is paused for reverse slow motion playback.

▶||/▶▶/▶▶ – Press during playback to start forward scanning. While playback is paused, press for step forward playback. Press and hold while playback is paused for forward slow motion playback.

13 RED/GREEN/BLUE/YELLOW

Use these to navigate BD-ROM menus.

14 VIDEO ADJUST

Press to display/hide the Video Adjust menu.

15 OPEN/CLOSE

Press to open and close the disc tray.

16 FL DIMMER

Press to switch the brightness of the front panel display. The **FL OFF** indicator lights when **Off** is selected.

17 ANGLE

Press to switch the BD-ROM or DVD-Video camera angles.

18 OUTPUT RESOLUTION

Use these to switch the output video resolution from the **HDMI OUT** terminal or **COMPONENT VIDEO** output terminals.

19 PLAY MODE

Press to display/hide the Play Mode screen.

20 POP UP MENU/MENU

Press to display the BD-ROM or DVD-Video menus.

21 DISPLAY

Press to display disc information.

22 TOOLS

Press to display/hide the **TOOLS** menu.

23 RETURN

Press to return to the previous screen.

[3] Front Panel Display

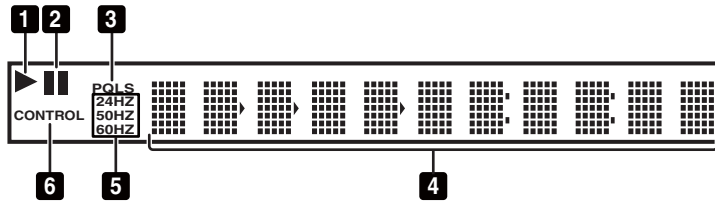

1 ▶
Lights during playback.

2 ▮
Lights when playback is paused.

3 PQLS
Lights when the PQLS function is activated.

4 Character display
Displays the title/chapter/track number, elapsed time, etc.

5 24HZ/50HZ/60HZ
The frequency of the video frame or field being output lights.

6 CONTROL
Lights when the HDMI Control function is activated.

[4] Rear Panel

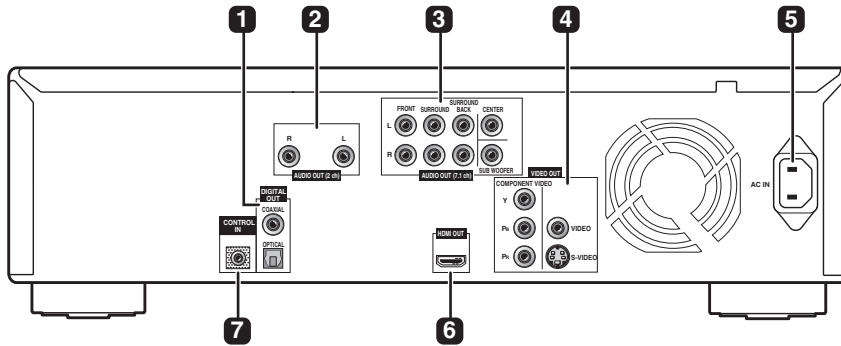

1 DIGITAL OUT (COAXIAL/OPTICAL)
Connect with the digital audio input terminal on an AV receiver or amplifier, etc.

2 AUDIO OUT (2 ch) terminals
Connect with the audio input terminals on a TV, AV receiver or amplifier, etc.

3 AUDIO OUT (7.1 ch) terminals
Connect with the multi-channel (7.1- or 5.1-channel) audio input terminals on an AV receiver or amplifier, etc.

4 VIDEO OUT terminals
VIDEO – Connect with the video input terminal on a TV, AV receiver or amplifier, etc.
S-VIDEO – Connect with the S-Video input terminal on a TV, AV receiver or amplifier, etc.
COMPONENT VIDEO – Connect with the component video input terminals on a TV, AV receiver or amplifier, etc.

5 AC IN
Connect the power cord here.

6 HDMI OUT terminal
Connect with an HDMI-compatible TV, AV receiver or amplifier, etc.

7 CONTROL IN terminal
Use to control this player from the remote sensor of another Pioneer component with a **CONTROL OUT** terminal and bearing the **SR** mark. Connect the **CONTROL OUT** of the other component to the **CONTROL IN** of this player using a mini-plug cord.

Caution

- Be sure to connect cables for outputting the audio and video signals.
- When connected via System Control, point the remote control toward the connected component (such as an AV receiver or amplifier). The remote will not work correctly when pointed at this player.
- You cannot use System Control with components that do not have a System Control terminal or with components manufactured by companies other than Pioneer.

3. BASIC ITEMS FOR SERVICE

3.1 CHECK POINTS AFTER SERVICING

Items to be checked after repair (BD players)

To ensure the quality of the product after repair, check the recommended items shown below:

No.	Procedures	Item to be checked
1	Check the version of the firmware in Service mode.	The version must be the latest. If the version is not the latest, update the firmware.
2	Check if all the symptoms pointed out by the customer have been addressed. If a symptom pointed out by the customer is attributable to a particular disc, that disc must be played back.	The symptoms in question must not be reproduced. Video, audio, and operations must be normal.
3	Measure playback error rates at the innermost and outermost tracks, by playing back the following discs: BD-ROM test disc (GGV1308) DVD test disc (GGV1025)	The error rates must be 1.0e-3 or less. This procedure can determine if the drive is degraded.
4	Check playback of a CD disc (track search).	Audio and operations, such as a search, must be normal.
5	Check playback of a DVD disc (menu operations, title/chapter search).	Video, audio, and operations, such as a search, must be normal.
6	Check playback of a BD disc (menu operations, title/chapter search).	Video, audio, and operations, such as a search, must be normal.
7	Check the cabinet.	Check for any scratches or dirt that have been made or attached on the cabinet after receiving the product for repair.

See the table below for the items to be checked regarding video and audio:

Item to be checked regarding video	Item to be checked regarding audio
Block noise	Distortion
Horizontal noise	Noise
Dot noise	Volume too low
Disturbed image (video jumpiness)	Volume too high
Too dark	Volume fluctuating
Too bright	Sound interrupted
Color disappearance	
Mottled color	

Cleaning



Before shipping out the product, be sure to clean the following positions by using the prescribed cleaning tools:

Position to be cleaned	Cleaning tools
Pickup lenses	Cleaning liquid : GEM1004 Cleaning paper : GED-008

Position to be cleaned	Cleaning tools
Fans	Cleaning paper : GED-008

3.2 PCB LOCATIONS

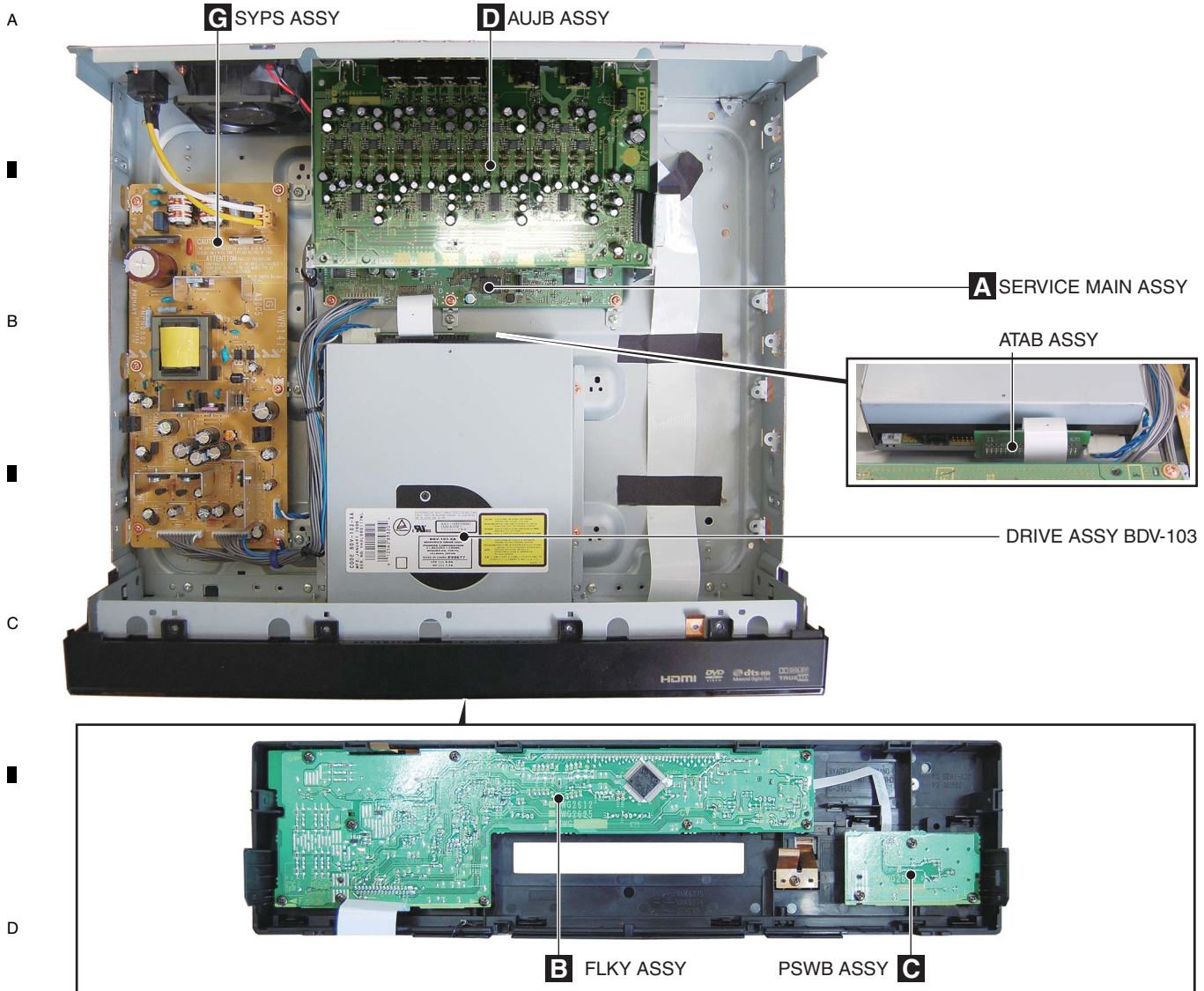

NOTES: ● Parts marked by "NSP" are generally unavailable because they are not in our Master Spare Parts List.
 ● The ⚠ mark found on some component parts indicates the importance of the safety factor of the part. Therefore, when replacing, be sure to use parts of identical designation.

Mark No.	Description	Part No.	Mark No.	Description	Part No.
LIST OF ASSEMBLIES					
	1..SERVICE MAIN ASSY	VXX3328	⚠	1..SYPS ASSY	VWR1415
NSP	2..MAIN ASSY (BDP2.0)	VWV2375			
	2..ATAB ASSY (BDP2.0)	VWV2360		1..DRIVE ASSY BDV-103	VXX3325
NSP	1..FLKB ASSY	VWM2481			
	2..FLKY ASSY	VWG2625			
	2..PSWB ASSY	VWG2613			
NSP	1..AUJB ASSY	VWG2632			

3.3 JIGS LIST

■ Jigs List

Name	Jig No.	Remarks
Service Remote Control Unit	GGF1067	Adjustment, diagnosis
DVD Test Disc (DVD-Video)	GGV1025	Check of DVD-Video
BD-ROM Test Disc	GGV1308	Check of BD-ROM
ID Data Disc for Blu-ray player Type 2 Vol 1.0	GGV1324	Diagnosis (ID data setting)
Disc Ejection Rod	GGF1529	Emergency Disc Ejection

A

B

C

D

E

F

4. BLOCK DIAGRAM

4.1 OVERALL WIRING DIAGRAM

A

B

C

D

E

F

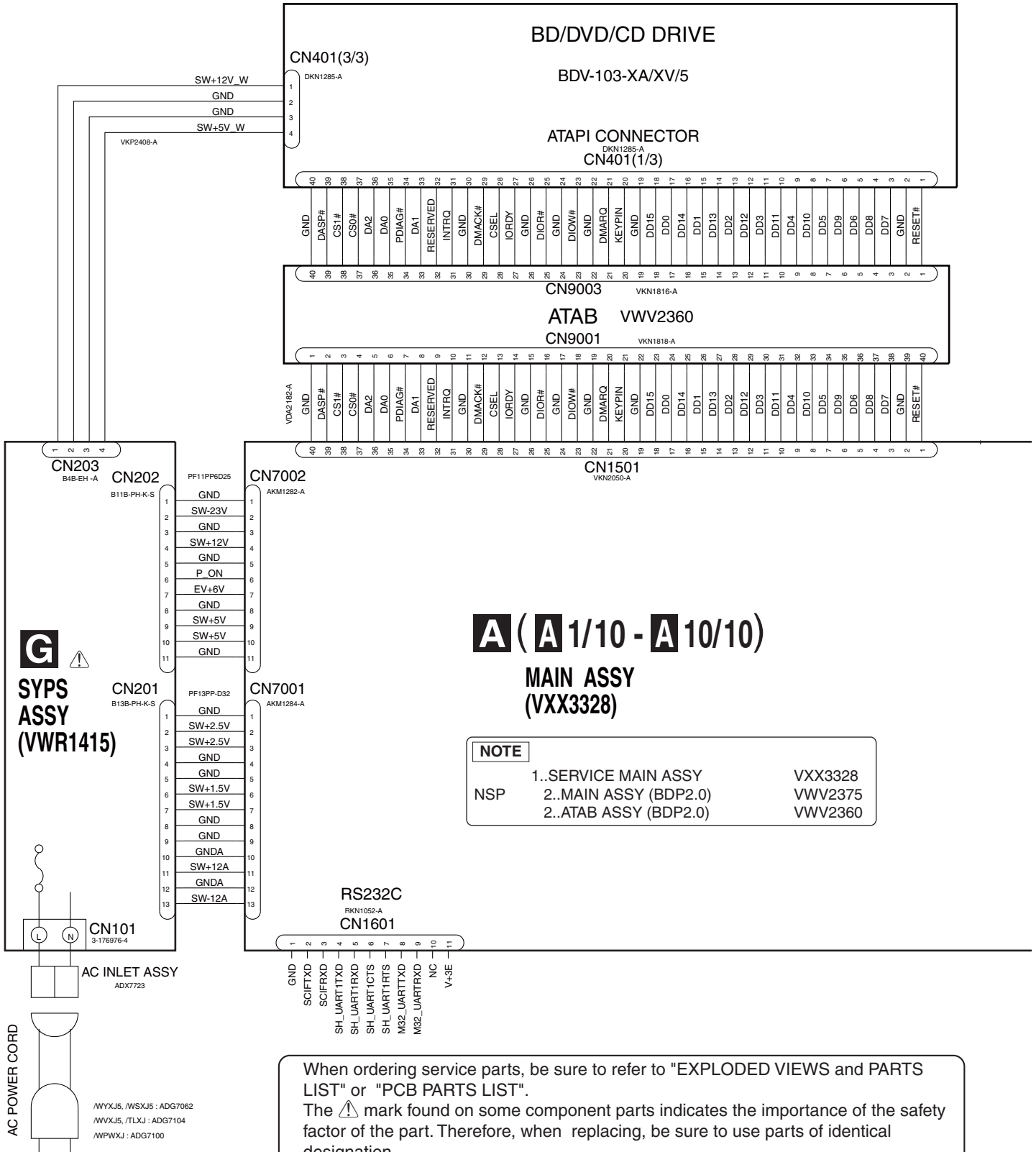

A (A 1/10 - A 10/10)
MAIN ASSY (VXX3328)

NOTE	
1..SERVICE MAIN ASSY	VXX3328
NSP 2..MAIN ASSY (BDP2.0)	VVV2375
2..ATAB ASSY (BDP2.0)	VVV2360

When ordering service parts, be sure to refer to "EXPLODED VIEWS and PARTS LIST" or "PCB PARTS LIST".
The ⚠ mark found on some component parts indicates the importance of the safety factor of the part. Therefore, when replacing, be sure to use parts of identical designation.

 : The power supply is shown with the marked box.

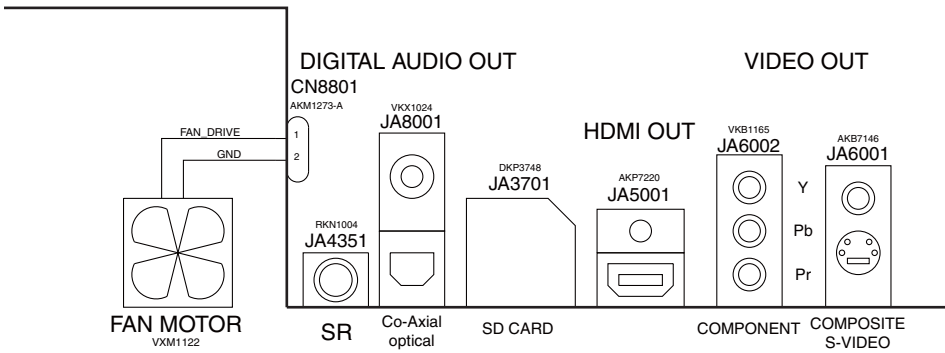
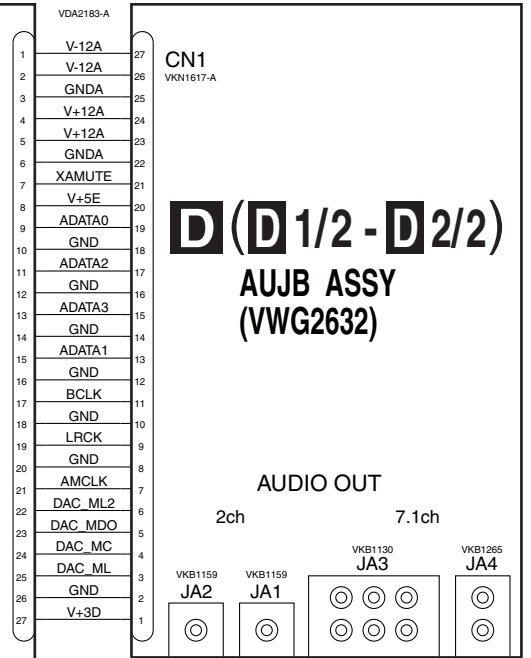
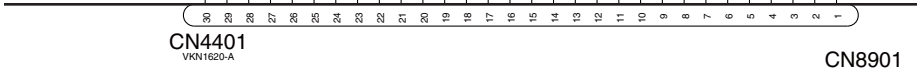
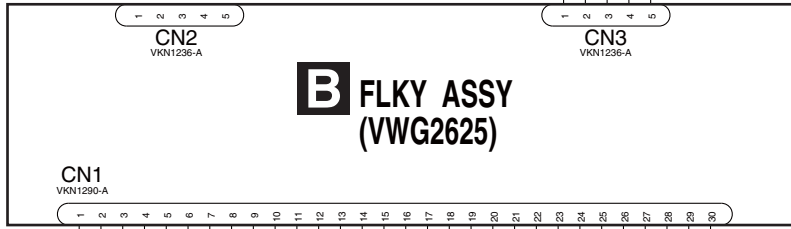

4.2 BLOCK DIAGRAM

A
B
C
D
E
F

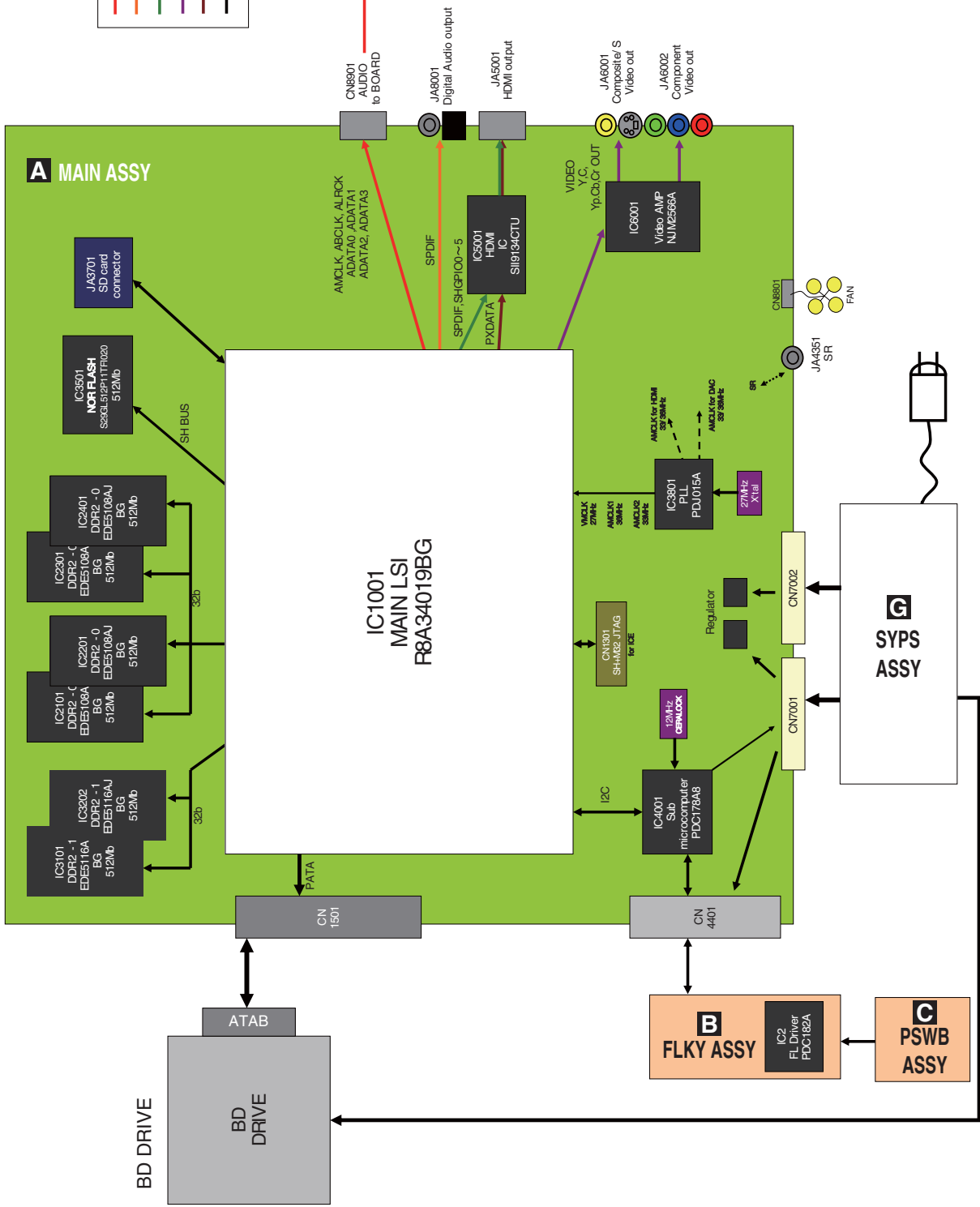
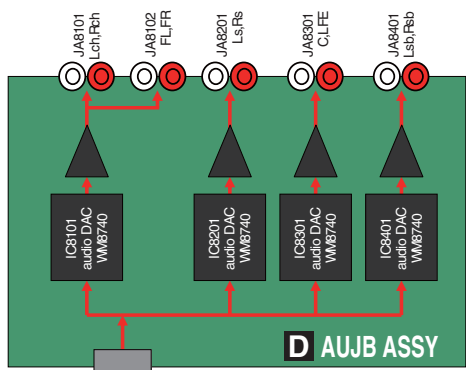
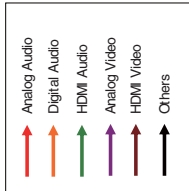

4.3 POWER BLOCK DIAGRAM

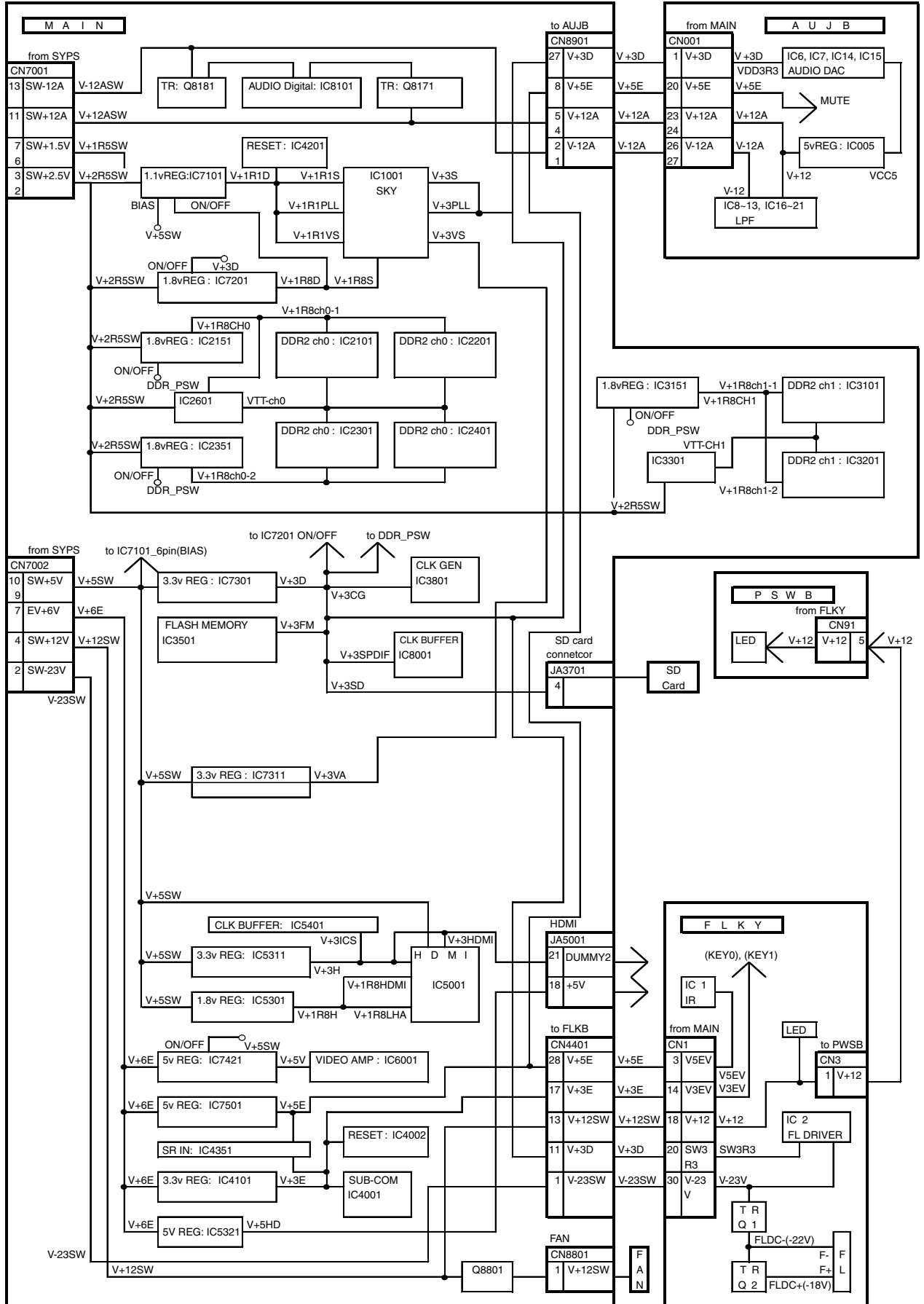

5. DIAGNOSIS

5.1 POWER ON SEQUENCE

[1] Power On Sequence

① Pressing of the POWER key is detected by the IC4001 Submicrocomputer on the MAIN Assy. The IC4001 then outputs a POWER_ON signal to the SYPS Assy.

② After receiving the POWER_ON signal, the SYPS Assy activates, secondary Power[SW+12 V], setting it to ON.

③ The R8A34019BG (IC1001), the core LSI, starts up. {RS-232C connectorCN1601, log it to ON}

④ Communication between the R8A34019BG and the DDR2 SDRAM starts.

⑤ Communication between the R8A34019BG and the FLASH_IC starts.

It takes about 1 minute to complete the startup process.

[2] Troubleshooting

① Are the pins at CN7001 and CN7002 supplied with voltages?
MAIN ASSY(1/10) V+3S, V+3PLL with 3.3 voltages?
MAIN ASSY(1/10) V+1R8S with 1.8 voltages?
MAIN ASSY(1/10) V+1R1S with 1.1 voltages?
Is the reset signal H? (R1161)
Is the 27 MHz CLK oscillating? (R1141)

② Power ON, and log of R8A34019BG stops with [DRAM failed].
R8A34019BG and communication failure of DDR memory.

③ Power ON, and log of R8A34019BG stops with [zboot failed].
R8A34019BG and communication failure of FLASH memory.

5.2 RESET ON SEQUENCE

[1] Block Diagram

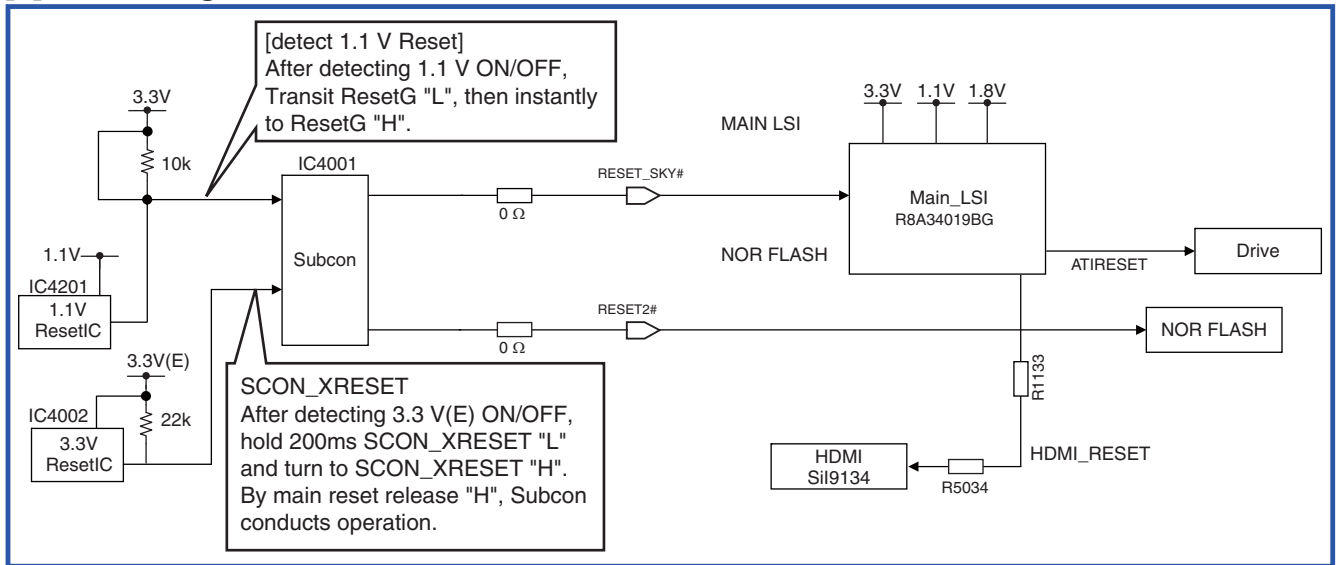

[2] Reset specification

[On start-up]

- ① Receiving Power ON key, sub-microcomputer turns Power_ON signal to "H".
- ② Receiving Power ON signal, power turns each SW power to "ON".
- ③ 1.1 V turns ON.
- ④ Sub-microcomputer is (after 400 ms) to Reset_SKY#, Reset 2#, Reset 3# "L" turn to "H".

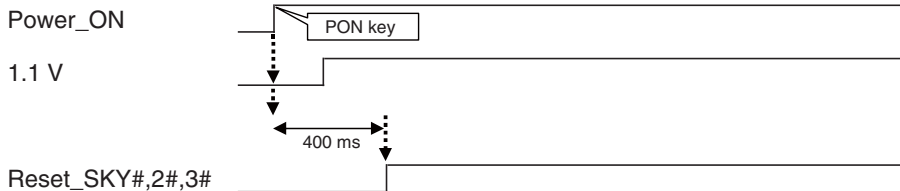

[At normal end]

- ① Sub-microcomputer detects the pushing of Power key, then notifies PowerOFF to R8A34019BG by I²C.
- ② Receiving PowerOFF notification, R8A34019BG conducts end processing.
- ③ R8A34019BG instructs PowerOFF to sub-microcomputer by I²C.
- ④ Sub-microcomputer turns Reset_SKY#, Reset 2#, Reset 3#, to "L", and after 1 sec, PowerON signal to "L".
- ⑤ After 50msec, power turns each SW power to OFF.

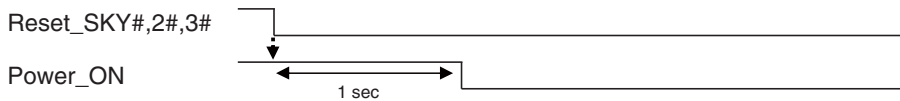

[Power abnormality]

*Reset operation in the case of 1.1 V drop.
Determine if ResetG becomes "L", then turn Reset# - Reset3# to "L".

[At abnormal end]

- ① ACOFF
- ② By turning V+1R1D to OFF, ResetG# turns to "L" by ResetIC.

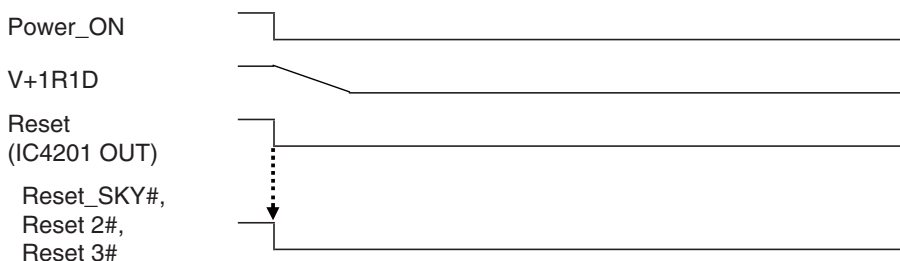

6. SERVICE MODE

6.1 OSD

[1] Indication items for the OSDs for debugging

Remote Control Unit Command	Screen	Indication Items for the OSDs	Remarks
[ESC]+[DISP]	1st screen	Service Indication (software information)	
		Product serial No./destination	
		Model No.	
		Released version No.	
		Revision No.	
		Submicrocomputer version data	
		Drive model No.	
		Drive version No.	
		Drive serial No.	
		DVD-Video region No.	
		BD-ROM region No.	
		CPRM ID	
		MAC address	
	2nd screen	OSD Filter	
	Setup value of the OSD FILTER	The data must be displayed on the subpage of the software information screen.	
[ESC]+[SIDE-B]	1st screen	Specifications 1 for error rate measurement (with OK/NG judgment)	
		Results of error rate measurement OK/NG	To see the result, press ESC then SIDE-B.
[ESC]+[DISP]+[2]	1st screen	Specifications 2 for error rate measurement (for continuous playback)	
		Title/Chapter data	
		Playback duration data	
		LgcSct address data	
		Error rate data (error rate value)	
[ESC]+[DISP]+[3]	1st screen	ATA/ATAPI DEBUG OSD-Command history (ALL)	
		Packet command from the host	
		Error data from the status register	
	2nd screen	ATA/ATAPI DEBUG OSD-Command history (ERROR)	
		Packet command that has been failed	
		Error Code	
	3rd screen	ATA/ATAPI DEBUG OSD-Drive maintenance data	
		Power ON/accumulated power-on duration	
		LD read power-on duration for the BD	
		LD read power-on duration for the DVD	
	4th screen	ATA/ATAPI DEBUG OSD-Judgment of LD degradation	
		Judgment of degradation of the LD for the BD (OK/NG)	
		Judgment of degradation of the LD for the DVD (OK/NG)	
		Judgment of degradation of the LD for the CD (OK/NG)	
		Temperature inside the writer	
	[ESC]+[DISP]+[4]		Results of self-diagnosis
Version/Revision Nos. of the SKY chip			
HDMI transmitter IC check			
Communication check of the submicrocomputer			
PLL synthesizer check			
DRIVE check			

Remote Control Unit Command	Screen	Indication Items for the OSDs	Remarks
[ESC]+[DISP]+[5]		AV output data Video data Video encoder data Component output resolution HDMI output resolution Frame rate Content resolution Content aspect ratio Data on VBID and WSS CGMS-A/Copyright APS MacroVision Aspect Audio data Sampling frequency Category code (Number of Bits & definition) Word Length C/L bit: Indications on number of bits & status (Free/Once/Disable) Audio muting status LPCM/BitStream output Number of output channels HDMI ACP Type	*These data are to be used merely as a guide, as they were designed to be used for product development.
[ESC]+[DISP]+[6] [ESC]+[DISP]+[7]		HDMI data Connection status * No data because screen specifications are to be designed by engineers for the HDMI modules.	* Two screens are to be used for HDMI data.
[ESC]+[DISP]+[8]		User Interface data Logs for received keys * No data because screen specifications are to be designed by engineers for the UI modules.	
[ESC]+[DISP]+[9]		Contents data BD-ROM HDMV BD-J Authoring maker Total number of titles BD-R/RE BDMV BDAV AVCHD Authoring maker Total number of titles DVD BDMV AVCHD DVD-Video DVD VR Authoring maker Total number of titles CD Total number of titles PC-FILES Total number of files	

A

B

C

D

E

F

Remote Control Unit Command	Screen	Indication Items for the OSDs	Remarks																						
[ESC]+[DISP]+[10]		Playback data (BD-ROM) <table border="1" data-bbox="483 352 1062 915"> <tr><td>Title No.</td></tr> <tr><td>Chapter No.</td></tr> <tr><td>Elapsed time within a title</td></tr> <tr><td>Video data</td></tr> <tr><td> Primary Video Stream</td></tr> <tr><td> Secondary Video Stream</td></tr> <tr><td> Resolution</td></tr> <tr><td> Source video aspect ratio</td></tr> <tr><td> Frame rate</td></tr> <tr><td> AACs data</td></tr> <tr><td> CPI</td></tr> <tr><td> CCI</td></tr> <tr><td> APS</td></tr> <tr><td> ICT</td></tr> <tr><td> DOT</td></tr> <tr><td> Audio data</td></tr> <tr><td> Primary Audio Stream</td></tr> <tr><td> Secondary Audio Stream</td></tr> </table>	Title No.	Chapter No.	Elapsed time within a title	Video data	Primary Video Stream	Secondary Video Stream	Resolution	Source video aspect ratio	Frame rate	AACs data	CPI	CCI	APS	ICT	DOT	Audio data	Primary Audio Stream	Secondary Audio Stream					
		Title No.																							
		Chapter No.																							
		Elapsed time within a title																							
		Video data																							
		Primary Video Stream																							
		Secondary Video Stream																							
		Resolution																							
		Source video aspect ratio																							
		Frame rate																							
		AACs data																							
		CPI																							
		CCI																							
		APS																							
ICT																									
DOT																									
Audio data																									
Primary Audio Stream																									
Secondary Audio Stream																									
[ESC]+[DISP]+[11]		Playback data (BD-R/RE) <table border="1" data-bbox="483 959 1062 1646"> <tr><td>Title No.</td></tr> <tr><td>Chapter No.</td></tr> <tr><td>Elapsed time within a title</td></tr> <tr><td>Navigation data</td></tr> <tr><td> Playback stream format</td></tr> <tr><td> SESF</td></tr> <tr><td> ISDB</td></tr> <tr><td>Video data</td></tr> <tr><td> Video stream data</td></tr> <tr><td> Playlist data (Virtual/Real-PlayList)</td></tr> <tr><td> Playlist No.</td></tr> <tr><td> Resolution</td></tr> <tr><td> Source video aspect ratio</td></tr> <tr><td> Frame rate</td></tr> <tr><td> AACs data</td></tr> <tr><td> CPI</td></tr> <tr><td> CCI</td></tr> <tr><td> APS</td></tr> <tr><td> ICT</td></tr> <tr><td> DOT</td></tr> <tr><td> Audio data</td></tr> <tr><td> Audio Stream data</td></tr> </table>	Title No.	Chapter No.	Elapsed time within a title	Navigation data	Playback stream format	SESF	ISDB	Video data	Video stream data	Playlist data (Virtual/Real-PlayList)	Playlist No.	Resolution	Source video aspect ratio	Frame rate	AACs data	CPI	CCI	APS	ICT	DOT	Audio data	Audio Stream data	
		Title No.																							
		Chapter No.																							
		Elapsed time within a title																							
		Navigation data																							
		Playback stream format																							
		SESF																							
		ISDB																							
		Video data																							
		Video stream data																							
		Playlist data (Virtual/Real-PlayList)																							
		Playlist No.																							
		Resolution																							
		Source video aspect ratio																							
Frame rate																									
AACs data																									
CPI																									
CCI																									
APS																									
ICT																									
DOT																									
Audio data																									
Audio Stream data																									

Remote Control Unit Command	Screen	Indication Items for the OSDs	Remarks
[ESC]+[DISP]+[12]	1st screen	Playback data (DVD)	
		Playback status data (PLAY, PAUSE, etc.)	
		Navigation data	
		Title No.	
		Chapter No.	
		Numbers of all chapters in a title	
		Elapsed time within a title	
		Elapsed time within a chapter	
		Number of multi-angles	
		Number of the selected multi-angle	
		Number of audio streams	
		Number of selected audio	
		Number of sub-pictures	
	No. of the selected sub-picture or OFF		
	2nd screen	Video data	
		Frame rate	
		Resolution	
		Aspect ratio	
		Progressive frame data	
Repeat first field data			
Maximum quantity/current quantity of video stream buffer			
Audio data			
Codec type			
Sampling frequency			
Number of channels			
(With LPCM) Quantization bit rate			
Maximum quantity/current quantity of audio stream buffer			
[ESC]+[DISP]+[13]	1st screen	Playback data (A/V decoder)	
		Primary A/V decoder data for DVD and BD	
		Error data of the video decoder	
	Error data of the audio decoder		
	2nd screen	Secondary A/V decoder data for BD	
		Error data of the video decoder	
Error data of the audio decoder			
[ESC]+[DISP]+[14]		Playback data (CD)	
		Audio data	
		Playback track/all tracks	
		Playback duration of the track	
		Playback duration of the disc	
		Total duration of the track	
Total duration of the disc			

A

B

C

D

E

F

Remote Control Unit Command	Screen	Indication Items for the OSDs	Remarks
[ESC]+[DISP]+[15]	1st screen	Playback data (PC Files)	
		Movie	
		Format (MPEG1/MPEG2-PS/MPEG2-TS/WMV...)	
		Resolution	
		NTSC/PAL	
		Aspect	
	2nd screen	Music	
		Format (MP3,WMA,WAV ...)	
		Fs	
		Bitrate	
		Channel number	
	3rd screen	Photo	
Format (JPEG/GIF/PNG ...)			
Resolution (Pixel)			
Aspect			
Date			
File name			
[ESC]+[AMON]+[TEST]		Destination setting screen	
		Input/setting of destination	
[ESC]+[STEREO]		CPRM ID Registration screen	
		ID registration	This screen is displayed when no ID is set.
		CPRM ID Clearing screen	
		Clearing of the registered ID	This screen is displayed when the ID has been set.

* For details on how to shift screens, see "[2] Service Indication Screens".

[2] Service Indication Screens

1. Overview

On Service Indication screens, data that are retained by the System Controller are displayed with the aid of the remote control unit for service (GGF1067). (Not for use by general users)

The maximum display area for on-screen displays is 64 one-byte characters (widthwise) × 17 lines (lengthwise).

2. How to Operate

To display indications for servicing, use the remote control unit for service.

• How to enter Service Indication mode

The following key input can be accepted either in Normal Startup mode or Service mode.

(1) Without any GUI displayed, press the ESC key.

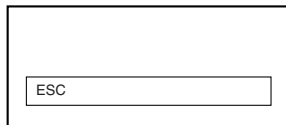

(2) Then press the DISP key. The 1st screen (version data, etc.) is displayed.

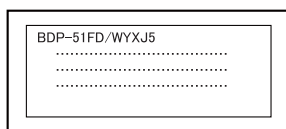

1st screen (version data, etc.)

(3) To shift to a subsequent screen, press the corresponding key:

[2]: 2nd screen: Error rate measurement 2 (for continuous playback)

[3]: 3rd screen: ATA/ATAPI debugging (drive data)

• How to exit Service Indication mode

Press the ESC key.

• How to shift between screens

To shift to the next screen, press the DISP key. To shift to the previous screen, press the CX key.

• How to shift between subscreens

To shift to the next subscreen, press the DIG/ANA key. To shift to the previous subscreen, press the TEST key.

3. Overview of Screen Shifting

An overview of screen shifting in Service Indication mode is given below.

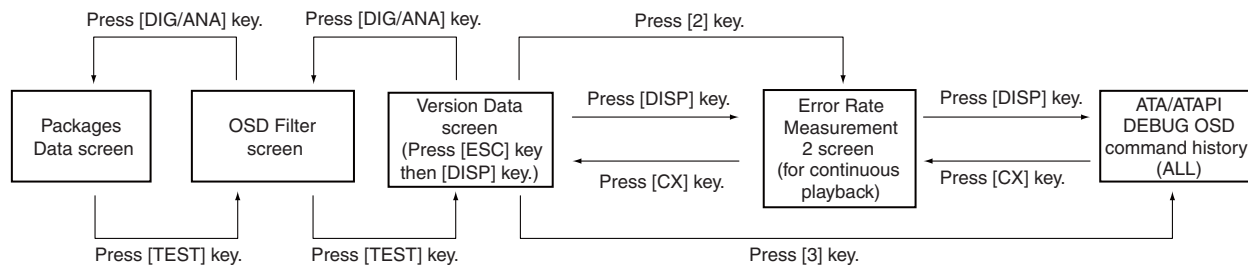

* To exit any screen, press the ESC key.

* For details on the Error Rate Measurement 2 screen, see the "Specifications 2 for Error Rate Measurement (for continuous playback)".

* For details on the OSD Filter screen, see the "OSD Filter Setting".

A 4. Specifications of Version Data screen

• 1st screen (version data, etc)

00	①	BDP-51FD/WYXJ5	
01	②	MODEL : 0205	
02	③	VERSION : 1.00	
03	④	REVISION : 1.6101.4.166 \$	
04	⑤	DRIVE : PIONEER BD-RW BDR-101AX	OK
05		DRIVE VER : 1.00	OK
06		DRIVE S/N : FLTP900007WL	
07	⑥	SUBCON : 1.00	OK
08	⑦	REGION : 1A	
09	⑧	CPRM ID : 000000001	
10	⑨	MAC ADDRESS : 00-E0-36-00-C7-FF	
11			
12			
13			
14			
15			
16			

① Data on the model: Model name/destination

② MODEL: Model No.

③ VERSION: Release version

④ REVISION: SVN Revision No.

⑤ DRIVE: Data on the built-in drive

Drive name: Judged as OK: The name assigned by the application program coincided with that obtained by the command.
 Judged as NG: The name assigned by the application program did not coincide with that obtained by the command.

DRIVE VER: Version of the firmware

Judged as OK: The version assigned by the application program coincided with that obtained by the command.
 Judged as NG: The version assigned by the application program did not coincide with that obtained by the command.

DRIVE S/N: Drive serial No. (For details on the drive serial No. indication, see the "Drive Serial No. Indication".)

⑥ SUBCON: Firmware version of the submicrocomputer (PIC)

Judged as OK : The version assigned by the application program coincided with that obtained by the command.

Judged as NG+ : The version obtained by the command is newer than that assigned by the application program.

Judged as NG- : The version obtained by the command is older than that assigned by the application program.

⑦ REGION: Region codes for DVD-VIDEO and BD-ROM of the player

The above screen example shows that the DVD region code is 1 and the BD region code is A.

If a region has not been set, "VIRGIN ROM" is displayed for the DVD, and "F" is displayed for BD.

⑧ CPRM ID: CPRM key No.

If it has not been set, "?????????" is displayed.

⑨ MAC ADDRESS: MAC ADDRESS value

If it has not been set, "?????????????????" is displayed.

• 2nd screen (OSD Filter Setting)

Video Setting		1080/24p
OSD FILTER	: No Filter	*

* For details on the OSD Filter screen, see the "OSD Filter Setting".

[3] OSD Filter Setting

* The details of this section are to be determined later after register specifications are determined.

To display the Service Indication screen, press the ESC then DISP keys. Then press the DIG/ANA key once to switch to the OSD Filter Setting screen. The above key inputs can be accepted either in Normal Startup mode or Checker mode.

• OSD Filter Setting screen

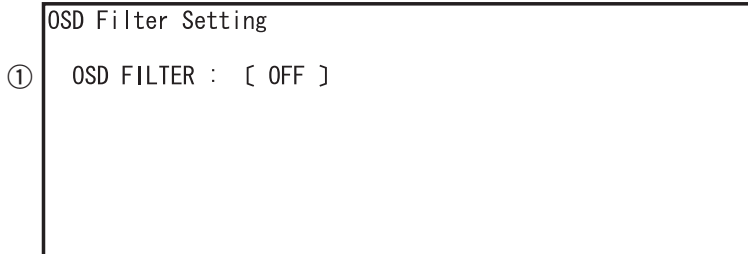

① OSD Filter Setting value ON
 OFF

Key operations of the OSD Filter Setting screen

Key	Operation	Setting value (*: Default)	Remarks
[<x3], [x3>]	For switching the OSD Filter Setting between ON or OFF	OFF/ON (*)	[<x3]: To set the OSD Brightness Filter to OFF [x3>]: To set the OSD Brightness Filter to ON
[ESC]	For clearing data or exiting the current mode	–	–

* Use the remote control unit for service for key operation.

* A setting becomes valid as soon as it is set. The setting value will be stored in nonvolatile memory, as with the setting values of the main unit. Therefore, the changed setting value will be retained upon the next power-on.

* About factory preset

- If the ESC then CLEAR keys are pressed ("No power off" command) for factory presetting, the setting will be reset to default (ON).
- If the STOP and POWER keys on the main unit are pressed simultaneously for factory presetting, the current setting will be retained.

[4] Simple Error Rate Measurement

To measure the error rate for a certain duration, press the ESC then SIDE-B keys only during playback. The result of judgment (OK/NG) will be displayed on the FL display and as an OSD.

To exit Error Rate Measurement mode, press the ESC key while the error rate is being measured.

After exiting Error Rate Measurement mode, if the ESC then SIDE-B keys are pressed again to reenter Error Rate Measurement mode, measurement of the error rate will start from the beginning.

The error rate is measured for up to 5 sessions, and the displayed result is updated after measurement for each session is performed.

At the end of 5 sessions, the average error rate for the entire measurement range will be displayed. If measurement sessions are interrupted before 5 sessions, the average error rate up to the point of interruption will be calculated and displayed.

A result will be judged as NG if the measured error rate exceeded the reference value. See "OK/NG judgment" below. (Only when the average error rate is judged as NG, the tray will be opened.)

Display Formats on the FL display and as an OSD

Operation	Display format	
	FL	OSD
Only during playback, if keys are pressed, calculation of error rate is started, and the results are displayed on the FL display and as an OSD. The symbol (-) (which indicates that measurement is not finished) flashes.	ERR x.xxE-x- (At lights out)	ERR RATE : x.xE-x (At lights out)
	ERR x.xxE-x- (At lighting)	ERR RATE : x.xE-x- (At lighting)
The result of measurement is displayed.		
If error rate measurement is completed before playback finishes, the average error rate, the symbol (*) (which indicates that the measurement is completed) and the judgment result (OK/NG) will be displayed on the FL and as an OSD. (When NG is displayed, if the tray is opened, the indications on the FL display and screen will be retained.)	ERR x.xxE-x*	ERR RATE : x.xE-* OK (NG: OSD whole screen display with red)
If error rate measurement is not completed before playback finishes, the average error rate, the symbol (-) (which indicates that measurement is not finished) and the judgment result (ERROR) that indicates that the error rate measurement has not been completed will be displayed on the FL display and as an OSD.	ERR x.xxE-x-	ERR RATE : x.xE-x- ERROR

* The layout for OSD depends on the mounting.

* "x.xE-X" in the above table indicates an error rate. E.g.: 3.5E-5 = 3.5X10⁻⁵

OK/NG judgment

Disc type	Reference value	Indication
DVD	1.0x10 ⁻³	OK/NG
BD	1.0x10 ⁻³	OK/NG
CD	No error rate measurement	

[5] ATA/ATAPI DEBUG OSD

Press the ESC, DISP, then 3 keys, in that order, to display the 1st screen for ATA/ATAPI DEBUG OSD. Then press the DIG/ANA key to switch screens.

• 3rd screen (ATA/ATAPI DEBUG OSD-Drive maintenance data)

ATA/ATAPI Drive MaintenanceInfo	
①	PowerON 0102:56
②	BD 0056:48
③	DVD 0023:48
④	CD 0034:04
⑤	PU Serial 00075898

- ① Accumulated power-on duration
- ② LD read power-on duration for the BD
- ③ LD read power-on duration for the DVD.
- ④ LD read power-on duration for the CD.
- ⑤ Serial No. of the PU

The power-on duration and error logs that the writer manages are displayed.

• 4th screen (ATA/ATAPI DEBUG OSD-Judgment of degradation of LDs)

ATA/ATAPI - LD Degrade	
BD	:104 % OK
DVD	: 96 % OK
CD	:101 % OK
TMP	: 41 °C

It is indicated to what extent the LDs (for BD, DVD, and CD) of the drive have degraded. To update the on-screen data, content and updating conditions, see Table 1 below:

Table 1: Display content and updating conditions

Display Item	Display Content
BD	Judgment of degradation of the LD for BD. NG with a rate of 120% or higher
DVD	Judgment of degradation of the LD for DVD. NG with a rate of 120% or higher
CD	Judgment of degradation of the LD for CD. NG with a rate of 120% or higher
TMP	Current temperature inside the writer

[6] Indications for the Results of Self-Diagnosis

Self-diagnosis is performed upon startup of the product, and the results are displayed as shown below.

• Specifications of indications for the results of self-diagnosis

Result of Self-Diagnostic	
①	SKY Chip Info : 2.00
②	HDMI Transmitter : OK
③	SUBCON : OK
④	PLL Synthesizer : OK
⑤	DRIVE : PIONEER BD-RW BDV-102X OK

- ① SKY Chip Info: Version and revision Nos. of the SKY Chip
- ② HDMI Transmitter: Result of checking communications with the SII9134CTU
- ③ SUBCON: Result of checking communications with the LC87F5932A
- ④ PLL Synthesizer: Result of checking communications with the CDCE906
- ⑤ DRIVE: Result of checking communications with the BD drive

1 2 3 4

7. DISASSEMBLY

Note 1: Do NOT look directly into the pickup lens. The laser beam may cause eye injury.
Note 2: Even if the unit shown in the photos and illustrations in this manual may differ from your product, the procedures described here are common.

Diagnosis of PCB's

1 Bonnet Case S and Tray Panel

● **Bonnet case S**

- ① Remove the eight screws.
- ② Remove the bonnet case S.

● **Tray panel**

- ① Press the STANDBY/ON button to turn on the power.
- ② Press the OPEN/CLOSE button to open the tray.
- ③ Remove the tray panel.
- ④ Press the OPEN/CLOSE button to close the tray.
- ⑤ Press the STANDBY/ON button to turn off the power.

The diagram shows the drive assembly with the bonnet case S removed. Callout 1 points to the top edge of the bonnet case. Callout 2 points to the tray panel. Callout 3 points to the tray. Callout 4 points to the tray panel. Callout 5 points to the top edge of the bonnet case. Labels 'Tray' and 'Tray panel' are also present.

● **How to open the tray when the power cannot be turned on**

When the tray cannot be opened because the power cannot be turned on, it can be opened using the emergency disc ejection rod (GGF1529). (A long, thin rod about 1 mm in diameter can be used in place of the rod.)

DRIVE Assy BDV-103
Emergency disc ejection rod (GGF1529)

Tray

34

BDP-51FD

1 2 3 4

2 Front Panel Section

① Remove the four screws.

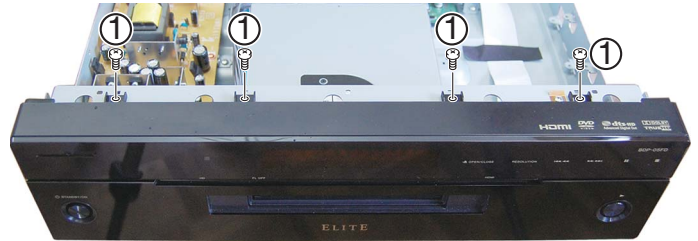

② Remove the three tapes.

③ Disconnect the one flexible cable.

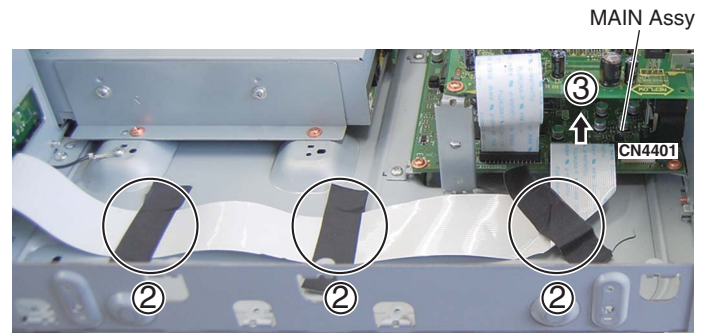

④ Unhook the four hooks.

⑤ Remove the front panel Section.

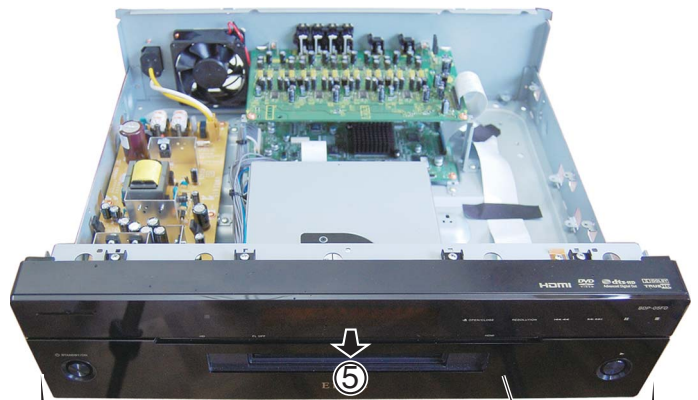

A 3 DRIVE Assy BDV-103

- ① Remove the ATAB Assy.
- ② Remove the one connector.
- ③ Release the jumper wires.
- ④ Remove the four screws.

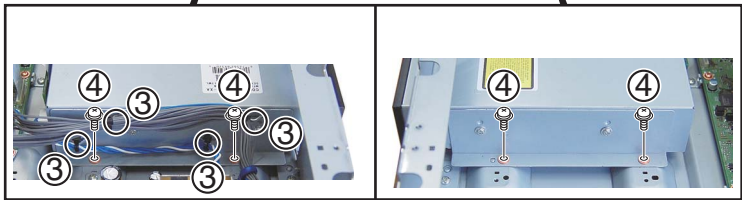
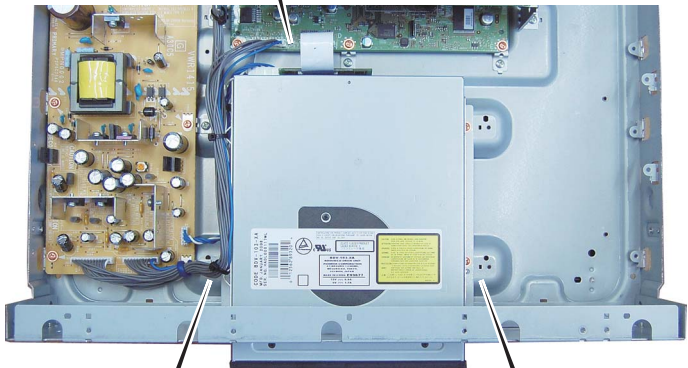
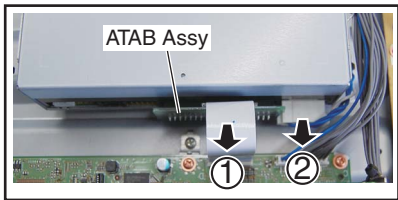

- ⑤ Remove DRIVE Assy BDV-103.

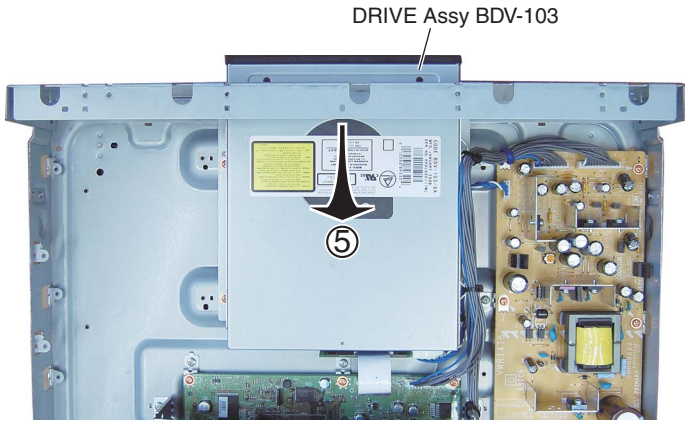

4 Rear Panel

- ① Disconnect the two connectors.
- ② Remove the two screws.
- ③ Remove the two screws.
- ④ Remove the eight screws.
- ⑤ Remove the one screw.
- ⑥ Remove the three screws.
- ⑦ Remove the rear panel.

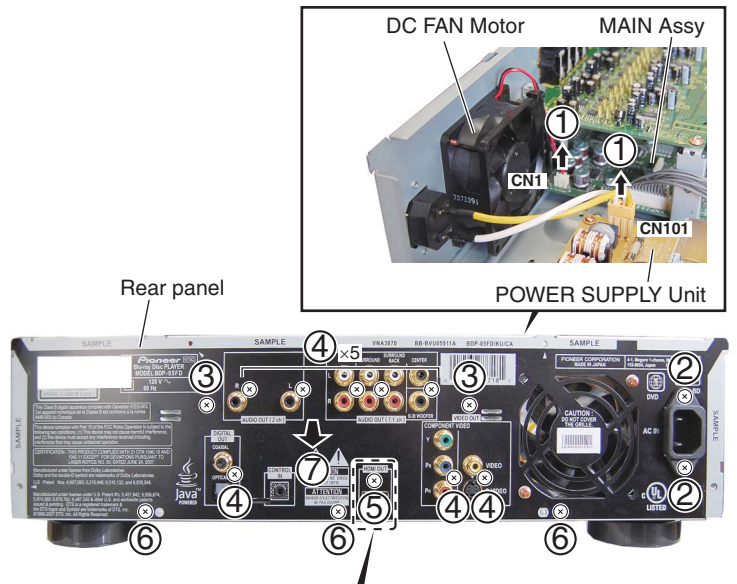

Note:
Do not use an electric screwdriver.
If the screw is over-tightened, the screw thread may be damaged.



5 AUJB and MAIN Assys

- ① Remove the two screws.
- ② Remove the AUJB Assy.

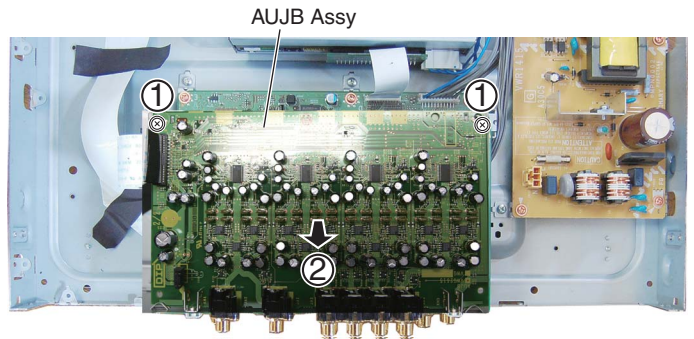

- ③ Remove the five screws.
- ④ Release the jumper wire.
- ⑤ Remove the MAIN Assy.

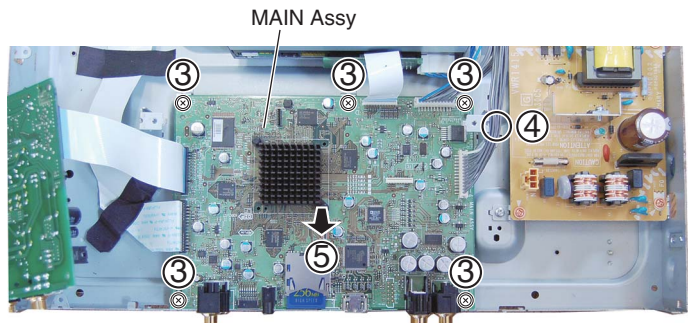

A **6** Diagnosis

- ① Reassembling the DRIVE Assy BDV-103.
- ② Reassembling the front panel Section.
- ③ Arrange the unit as shown in the photo below.



Diagnosis

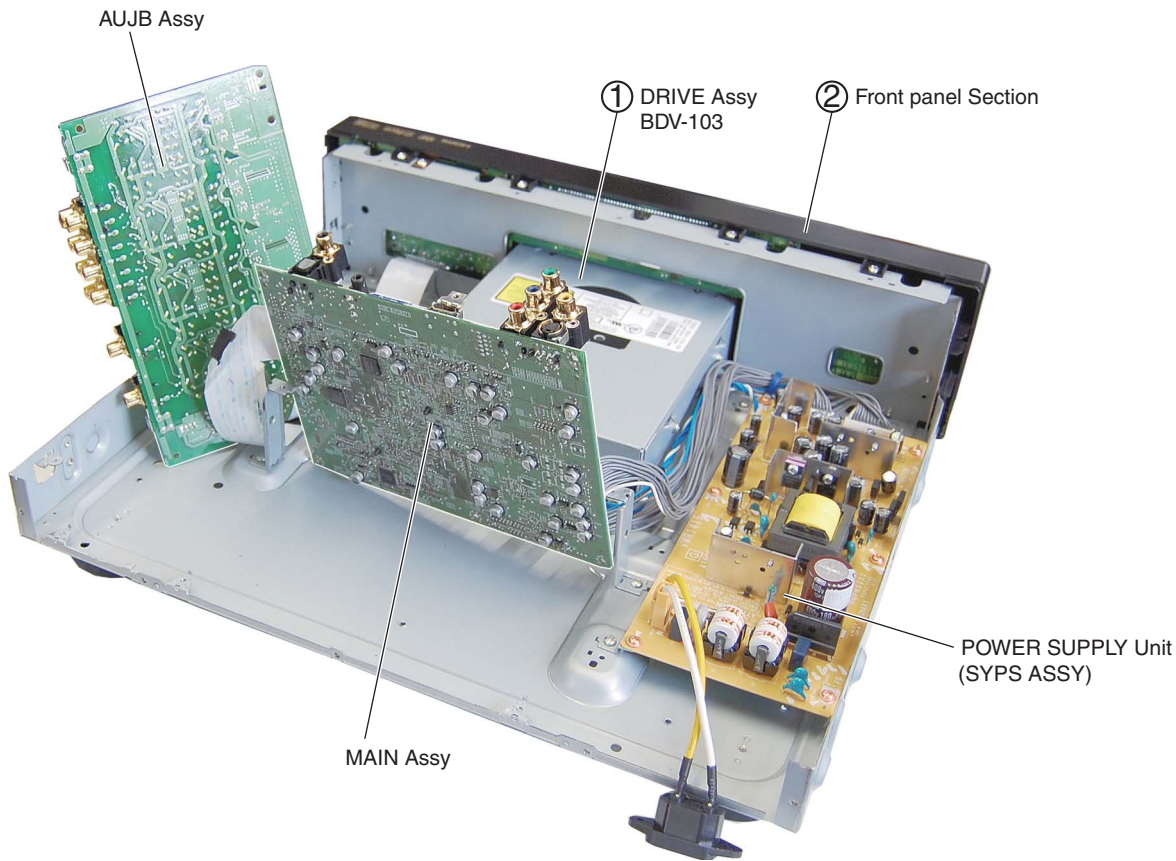

Cleaning the Pickup Lens

● Writer stay L and R

- ① Remove the four screws.
- ② Remove the writer stays L and R.

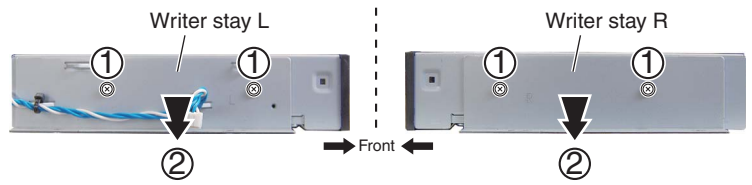

● Front bezel

- ① Unhook the four hooks.
- ② Remove the front bezel.

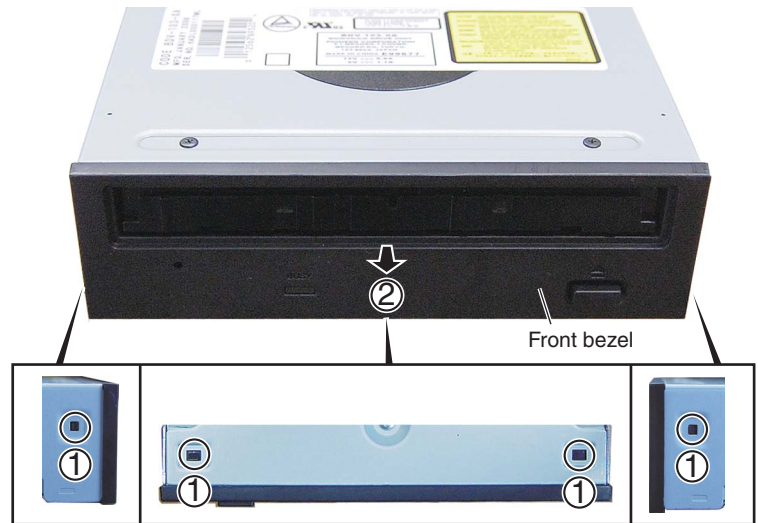

● Upper case

- ① Remove the four screws.

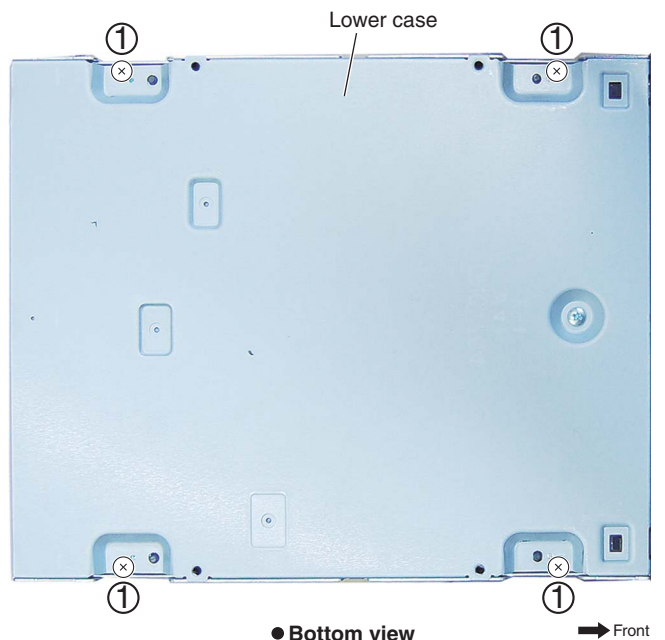

● Bottom view

→ Front

A

- ② Remove the three screws.
- ③ Remove the upper case.

Upper case



B

C

● Clamper

- ① Remove the four screws.
- ② Remove the clamper.

Clamper

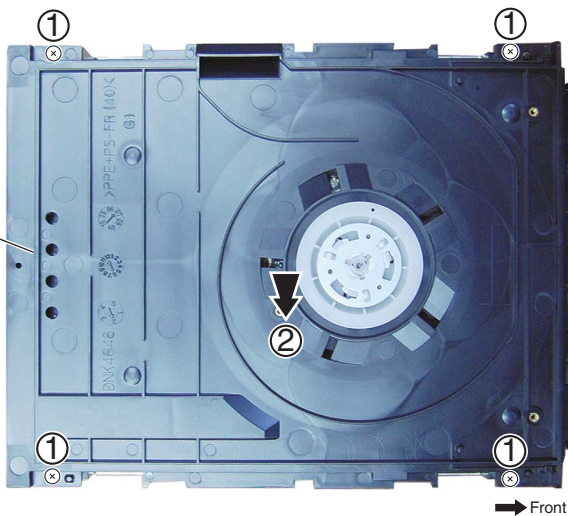

D



Before shipment, be sure to clean the pickup lenses, using the following cleaning materials:

- Cleaning liquid : GEM1004
- Cleaning paper : GED-008

Pickup lenses

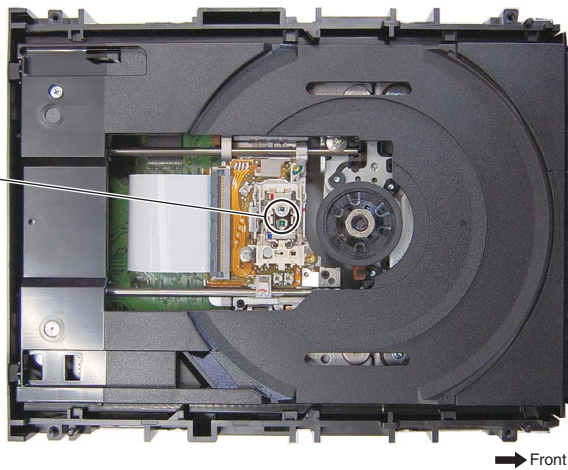

F

8. EACH SETTING AND ADJUSTMENT

8.1 NECESSARY ADJUSTMENT POINTS

When

Adjustment Points

■ Exchange Parts of Mechanism Assy

Exchange the DRIVE ASSY



Mechanical point • None

Electric point • ID NUMBER and DATA SETTING
• FIRMWARE UPDATE

■ Exchange PCB Assy

Exchange MAIN ASSY



Mechanical point • None

Electric point • MODEL SETTING
• ID NUMBER and DATA SETTING
• FIRMWARE UPDATE

8.2 MODEL SETTING

[1] Destination Setting Screen

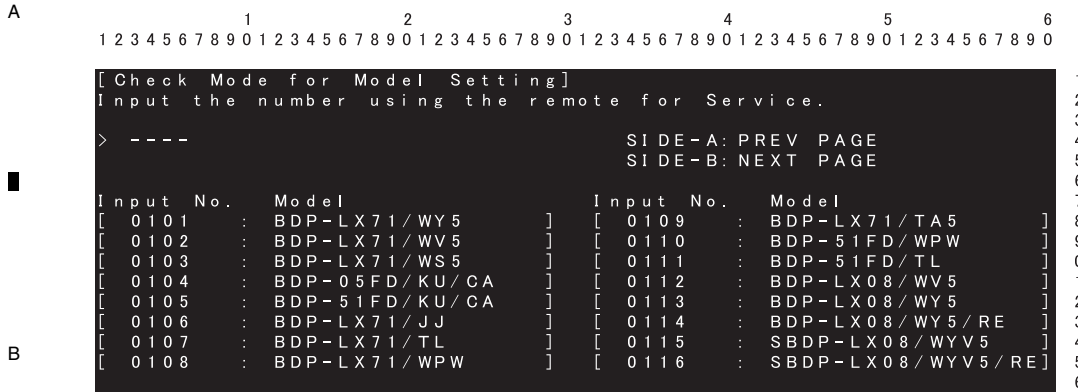

Fig. 1: Screen image 1

- The screen for setting the destination region will be analogous to the screen shown in Fig. 1.
- A proportional font will be used.
- Entering a 4-digit number is possible with the remote control unit for service (Fig. 2).
- To shift to the next page, the SIDE-B key is used. When this key is pressed while the last page is displayed, Page 1 will be displayed.
- To shift to the previous page, the SIDE-A key is used. When this key is pressed while Page 1 is being displayed, the last page will be displayed.
- The input numbers and model names will be changed when pages are changed (Fig. 3).
- Other indications and operations are common to all pages.
- If there are several pages, any destination number will be accepted regardless of the currently displayed page.
- To exit the Destination Setting screen, press the ESC key.

On input keys

Key	Operation
Keys 0-9 on the remote control unit for service	For inputting numerics.
CLEAR key on the remote control unit for service	For canceling input numerics and returning to the initial display.

Keys other than those mentioned above will not be accepted.

- Once all 4 digits are input, that number is set.
- > If a number corresponding to the input number does not exist, the error message will be displayed. (Fig. 4)
- > After the error message is displayed, no key input will be accepted. (Unplug the power cord.)
- The first input numeric is displayed at the rightmost position then will be shifted to the left with subsequent key inputs, as shown below:

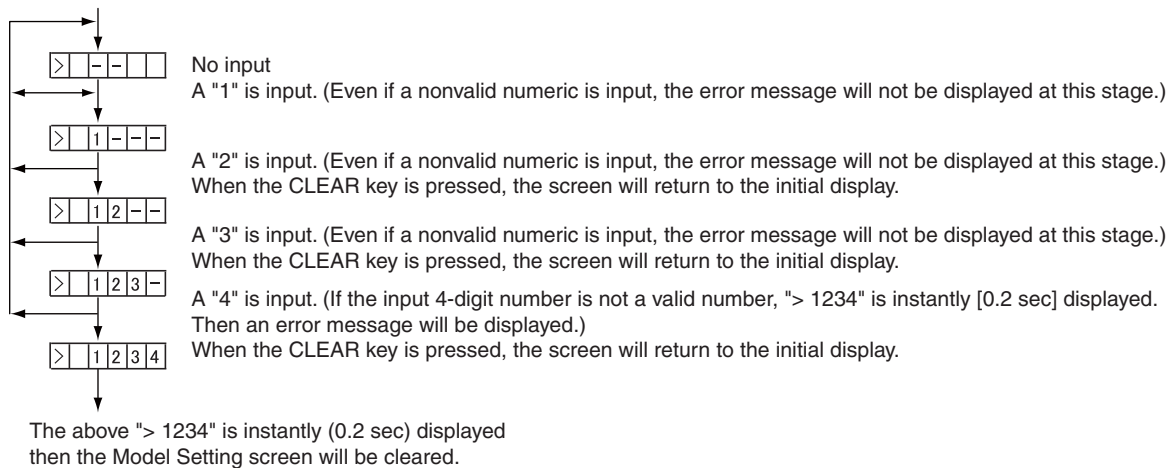

- To correct the input data, press the CLEAR key on the remote control unit for service. All the input numerics will be cleared.

• On the model indications

- The model number then the destination are indicated in the Model column.
- A full model number is indicated (16 one-byte characters at maximum).
- The model numbers and destinations are displayed in alphabetical and ascending numeric orders, from the top line in the left column.
- If the corresponding number exists:
 - > The model and region numbers are displayed for 2 sec. (Fig. 5)
 - > Then the unit will be turned off.

• FL display

While the Model Setting screen is displayed:

MODEL SET

If the input model number exists:

MODEL OK (After this indication is displayed for 2 sec, the unit is turned off.)

If the input model number does not exist:

MODEL ERR

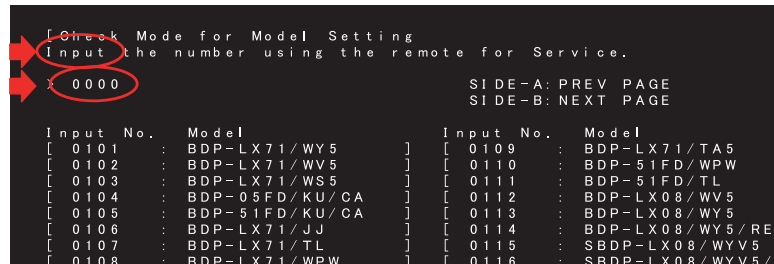

Fig. 2: Screen image 2

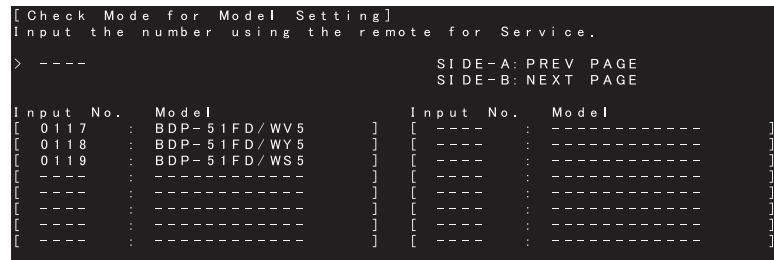

Fig. 3: Screen image 3

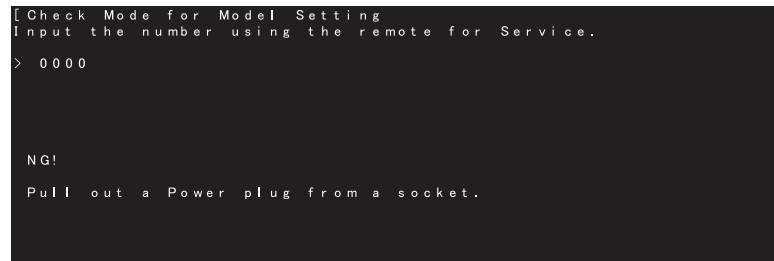

Fig. 4: Screen image 4

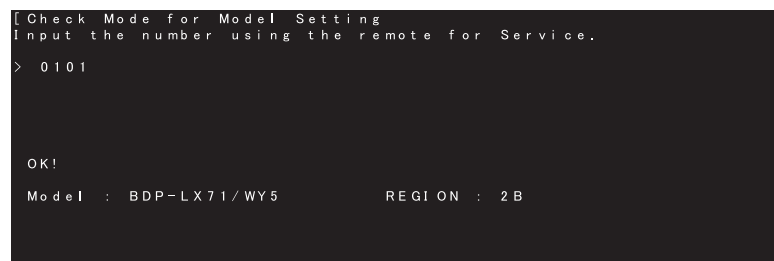

Fig. 5: Screen image 5

8.3 CPRM ID NUMBER AND DATA SETTING

[Purposes]

- An individual ID number and ID data (AACs, CPRM, BD+, Windows Media DRM, and MAC address) must be input at the same time. All data are determined according to the data on the ID data disc. If the number and data are not set correctly with the following procedure, the unit does not work properly. You will find the ID number to be labeled on the rear panel.

This setting is Necessary When:

- When the DRIVE Assy or MAIN Assy is replaced.

[Tools to be used]

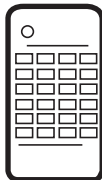

Remote control unit for servicing
(GGF1067)



ID Disc for Blu-ray Player Type 2 Vol 1.0
(GGV1324)

[Notes]

Important: If no ID label is found on the rear panel, write down the specified ID number by checking it on the version check screen ([ESC] + [DISP]).

- Input the ID number while the unit is in Stop mode.
- After the data are read from the ID data disc, the disc will automatically be unloaded.
- Each time a key input succeeds, the screen background becomes blue. If a key input fails, the screen background becomes red.

[1] CPRM ID Registration Mode

- Conditions for entering CPRM ID Registration mode**
During Playback Stop mode, press the ESC then STEREO keys.

The above key inputs are accepted only during Normal Playback Stop mode.

- Conditions for exiting CPRM ID Registration mode**
Press the CLEAR key to return to Normal mode.

- How to input the ID No. and ID data**

① To enter Input mode, press the ESC then STEREO keys.

② After entering Input mode, input a 9-digit ID No.

(The number is displayed on the FL display.)

The ID No. is described on the ID label located on the rear panel of the product.

③ After the 9-digit ID No. is input, the SEARCH key will be accepted. If it is pressed, the ID No. will be displayed.

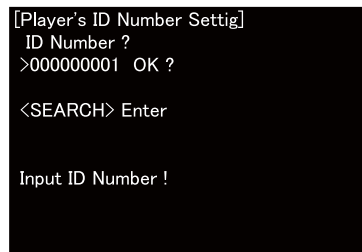

④ After the ID No. is set, the unit awaits ID data input. ("INSERT ID DATA" is displayed on the FL display.) Load the ID data disc in the disc tray. As soon as the tray is closed, reading of the data will start.

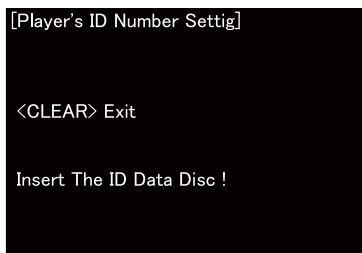

② →

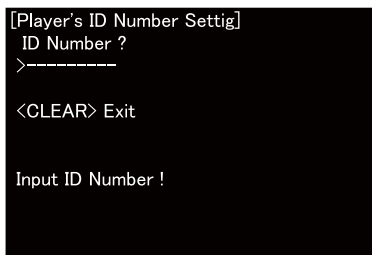

④ →



- ⑤ During data reading, the indications below will be displayed. ("LOAD ID DATA" is displayed on the FL display.)



- ⑥ After reading of the ID data is completed, writing of the data on the flash ROM will start. ("WRITE ID DATA" is displayed on the FL display.)

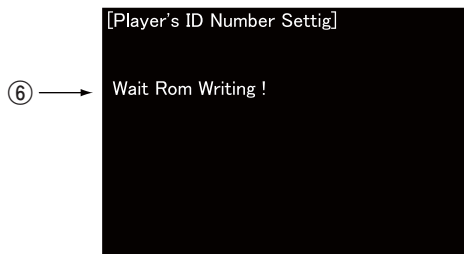

- ⑦ Upon completion of writing on the flash ROM, "Rom Write OK!" will be displayed. ("ID DATA OK" will be displayed on the FL display.)
The background color of the screen will change to blue when writing of various key data is successfully completed. If writing fails, the background color will change to red.
- ⑧ Upon completion of writing, press the CLEAR key to exit Input mode.

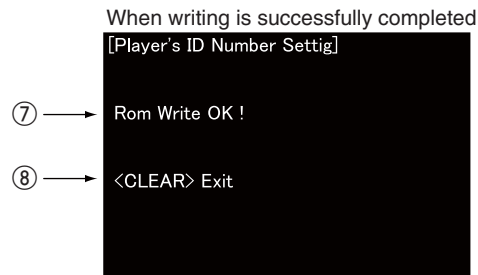

When writing fails

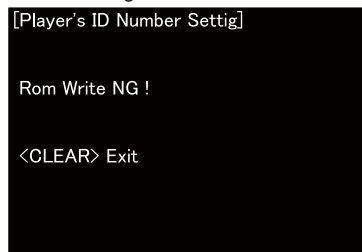

[2] CPRM ID Registration Mode 2

• How to clear the ID No.

- ① With the ID No. set, press the ESC then STEREO keys.
- ② Input the same number as the set ID No.

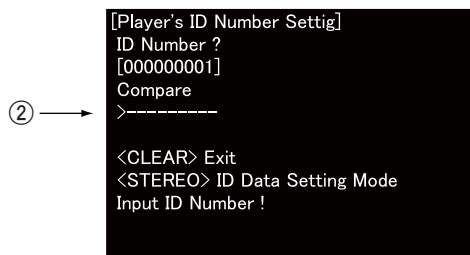

- ③ Press the STOP key after the 9-digit number is input. Only when the input number and the set number coincide, the set ID No. will be erased, and the unit will exit this mode. If the numbers do not coincide, the screen will return to that in Step ②. (The STOP key is not accepted after input of a 9-digit number is finished.)

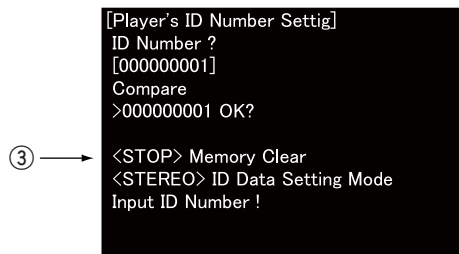

• Example of the FL display during numeric input for the ID No.

When the numerics 0, 1, and 2 are input, in that order:
[012]

* If an ID No. is already registered, the registered ID No. is displayed before you enter any numeric. (The registered ID No. also remains displayed when a wrong ID No. is input [NG].)

Before any numeric is input (registered ID: 012345678)
[012345678]

When the first digit (0) is input
[0]

8.4 FIRMWARE UPDATE

UPDATE PROCEDURE

1. Plug a power cable into the unit.
2. Press the "STANDBY/ON" button to switch the unit on.
3. Press the "OPEN/CLOSE" button to open the disc tray.
4. Place an UPDATE disc on the tray.
5. Press the "OPEN/CLOSE" button on the front panel to begin the application update.
 - * FL display indicates "DL OK" and the unit automatically switches into standby with the tray opening.
 - * The update time takes 5 to 25 minutes, it changes depending on the version.

DO NOT unplug the power cable or press the standby button until the unit switches into standby mode.

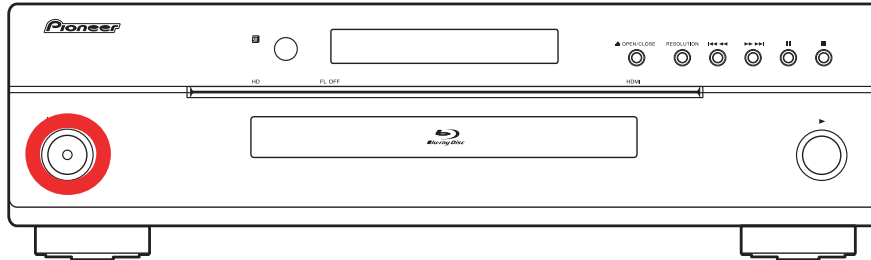

6. Remove the UPDATE disc from the tray.
7. Press the "STANDBY/ON" button to switch the unit on, and check if FL display indicates "DL OK". The update is completed if FL display indicates "DL OK".

■

5

■

6

■

7

■

8

■

A

■

B

■

C

■

D

■

E

■

F

■

5

■

6

BDP-51FD

■

7

■

8

■

9. EXPLODED VIEWS AND PARTS LIST

NOTES: ● Parts marked by "NSP" are generally unavailable because they are not in our Master Spare Parts List.

- The \triangle mark found on some component parts indicates the importance of the safety factor of the part. Therefore, when replacing, be sure to use parts of identical designation.
- Screws adjacent to ∇ mark on product are used for disassembly.
- For the applying amount of lubricants or glue, follow the instructions in this manual. (In the case of no amount instructions, apply as you think it appropriate.)

9.1 PACKING SECTION

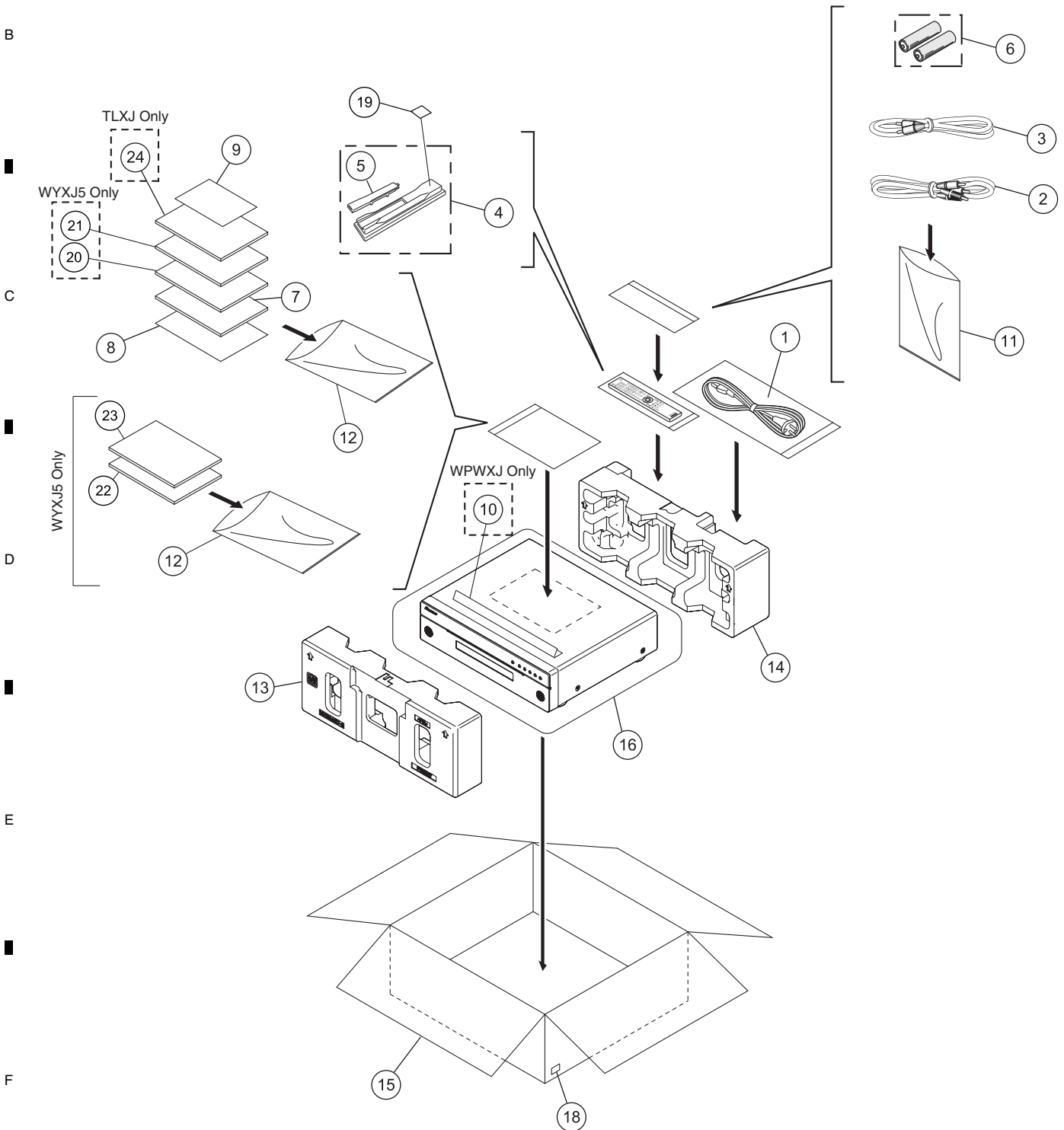

(1) PACKING SECTION PARTS LIST

Mark No.	Description	Part No.
⚠	1 Power Cable	See Contrast table (2)
	2 Audio Cable (white/red plugs)	XDE3045
	3 Video Cable (Yellow plugs)	XDE3046
	4 Remote Control	VXX3318
	5 Battery Cover	VZN1025
NSP	6 AA/R6 dry cell batteries	XEX3004
	7 Operating Instructions (English)	See Contrast table (2)
NSP	8 Warranty Card	See Contrast table (2)
NSP	9 Update Guide (Paper)	See Contrast table (2)
NSP	10 L Label (Paper)	See Contrast table (2)
	11 Polyethylene Bag	VHL1051
NSP	12 Polyethylene Bag	Z21-038
	13 Front Pad (PS)	VHA1437
	14 Rear Pad (PS)	VHA1438
	15 Packing Case (Paper)	See Contrast table (2)
	16 Packing Sheet	AHG7010
	17 •••••	
NSP	18 Serial Label S	VRW2017
	19 Label (WEEE)	See Contrast table (2)
	20 Operating Instructions(French)	See Contrast table (2)
	21 Operating Instructions(German)	See Contrast table (2)
	22 Operating Instructions(Italian)	See Contrast table (2)
	23 Operating Instructions(Spanish)	See Contrast table (2)
	24 Operating Instructions (Trad-Chinese)	See Contrast table (2)

(2) CONTRAST TABLE

BDP-51FD/WYXJ5, /WVXJ5, /WSXJ5, /TLXJ and BDP-51FD/WPWXJ are constructed the same except for the following:

Mark	No.	Symbol and Description	BDP-51FD /WYXJ5	BDP-51FD /WVXJ5	BDP-51FD /WSXJ5	BDP-51FD /TLXJ	BDP-51FD /WPWXJ
⚠	1	Power Cable	ADG7062	ADG7104	ADG7062	ADG7104	ADG7100
	7	Operating Instructions (English)	VRB1511	VRB1511	Not used	VRB1512	VRB1512
	7	Operating Instructions (Russian)	Not used	Not used	VRC1530	Not used	Not used
NSP	8	Warranty Card	ARY7128	ARY7128	ARY7128	Not used	Not used
NSP	9	Update Guide (Paper)	VRY1176	VRY1176	VRY1176	VRY1178	VRY1178
NSP	10	L Label (Paper)	Not used	Not used	Not used	Not used	VRW2382
	15	Packing Case (Paper)	VHG2913	VHG2914	VHG2915	VHG2907	VHG2908
	19	Label (WEEE)	ARW7322	ARW7322	ARW7322	Not used	Not used
	20	Operating Instructions (French)	VRC1526	Not used	Not used	Not used	Not used
	21	Operating Instructions (German)	VRC1527	Not used	Not used	Not used	Not used
	22	Operating Instructions (Italian)	VRC1528	Not used	Not used	Not used	Not used
	23	Operating Instructions (Spanish)	VRC1529	Not used	Not used	Not used	Not used
	24	Operating Instructions (Trad-Chinese)	Not used	Not used	Not used	VRC1532	Not used

9.2 EXTERIOR SECTION

1

2

3

4

A

B

C

D

E

F

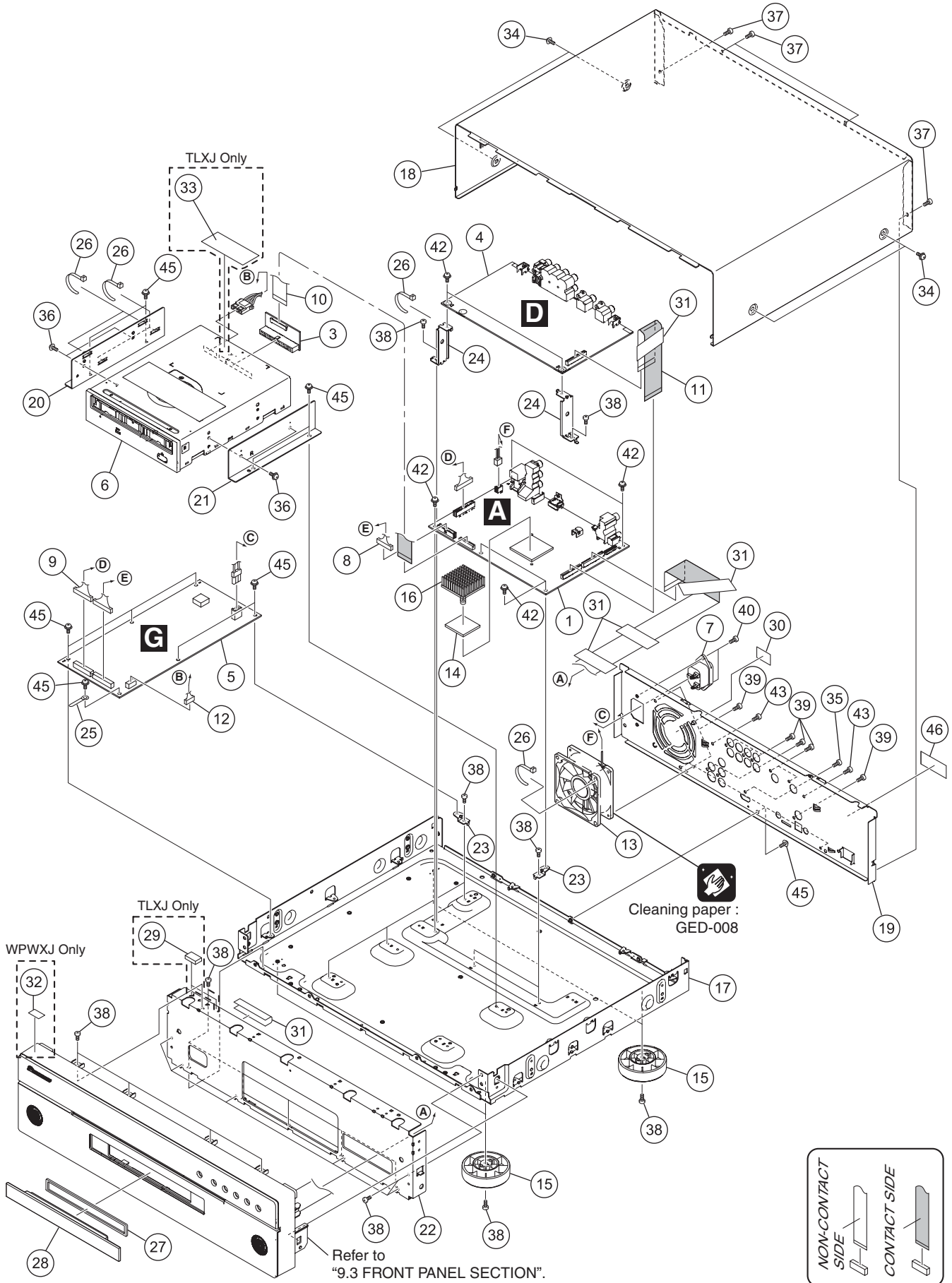

Cleaning paper :
GED-008

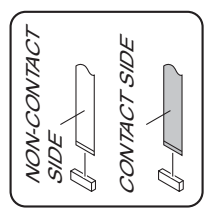

Refer to
"9.3 FRONT PANEL SECTION".

BDP-51FD

1

2

3

4

(1) EXTERIOR SECTION PARTS LIST

<u>Mark No.</u>	<u>Description</u>	<u>Part No.</u>	<u>Mark No.</u>	<u>Description</u>	<u>Part No.</u>
	1 SERVICE MAIN Assy	VXX3328	NSP 26	Binder (BK-1)	ZCA-BK1
	2 •••••		27	Tray Sheet (EPDM)	VEC2593
	3 ATAB Assy (BDP2.0)	VWV2360	28	Tray Panel (ABS)	VNK6342
NSP 4	AUJB Assy	VWG2632	29	Gasket 10 x 15T (PLA)	See Contrast table (2)
⚠ 5	SYPS ASSY	VWR1415	NSP 30	ID Label Assy	VXW1021
	6 DRIVE Assy	VXX3325	NSP 31	Tape	ZTA-156A-19
	(BDV-103-XA/XV/5)		NSP 32	Energy Star Label	See Contrast table (2)
⚠ 7	AC Inlet Assy	ADX7723	33	Laser Caution Chh	See Contrast table (2)
8	Connector Assy	PF11PP6D25	34	CSM Screw C 4 x 6 (B)	ABA7137
9	Connector Assy	PF13PP-D32	35	Screw (FE)	VBA1088
10	Flexible Cable (40 PIN)	VDA2182			
	11 Flexible Cable 27P	VDA2183	36	Screw	AMZ30P060FTC
	12 Housing Assy (4P)	VKP2408	37	Screw	BBZ30P060FTB
	13 DC FAN Motor	VXM1122	38	Screw	BBZ30P060FTC
	14 Thermal Sheet B	AEB1417	39	Screw	BPZ30P080FTC
	15 Insulator	PNW2766	40	Screw	CBZ30P080FTC
	16 Heat Sink B	ANH1645	41	•••••	
NSP 17	Base Chassis	VNA3062	42	Screw	IBZ30P060FCC
	18 Bonnet Case S	VXX3324	43	Screw	BBZ30P060FTC
	19 Rear Panel	See Contrast table (2)	44	•••••	
NSP 20	Writer Stay L	VNE2486	45	Screw	BBZ30P060FTC
NSP 21	Writer Stay R	VNE2487	NSP 46	Serial Label S	VRW2017
NSP 22	Front Stay	VNE2488			
NSP 23	PCB Stay	VNE2489			
NSP 24	Rear Stay	VNE2490			
	25 Cord Clip	VNX1026			

(2) CONTRAST TABLE

BDP-51FD/WYXJ5, /WVXJ5, /WSXJ5, /TLXJ and BDP-51FD/WPWXJ are constructed the same except for the following:

<u>Mark</u>	<u>No.</u>	<u>Symbol and Description</u>	<u>BDP-51FD</u> <u>/WYXJ5</u>	<u>BDP-51FD</u> <u>/WVXJ5</u>	<u>BDP-51FD</u> <u>/WSXJ5</u>	<u>BDP-51FD</u> <u>/TLXJ</u>	<u>BDP-51FD</u> <u>/WPWXJ</u>
	19	Rear Panel	VNA3087	VNA3087	VNA3088	VNA3085	VNA3086
NSP	29	Gasket 10 x 15T (PLA)	Not used	Not used	Not used	VEC2608	Not used
	32	Energy Star Label	Not used	Not used	Not used	Not used	AAX8022
	33	Laser Caution Chh	Not used	Not used	Not used	VRW2383	Not used

9.3 FRONT PANEL SECTION

A

B

C

D

E

F

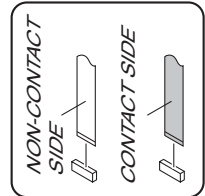
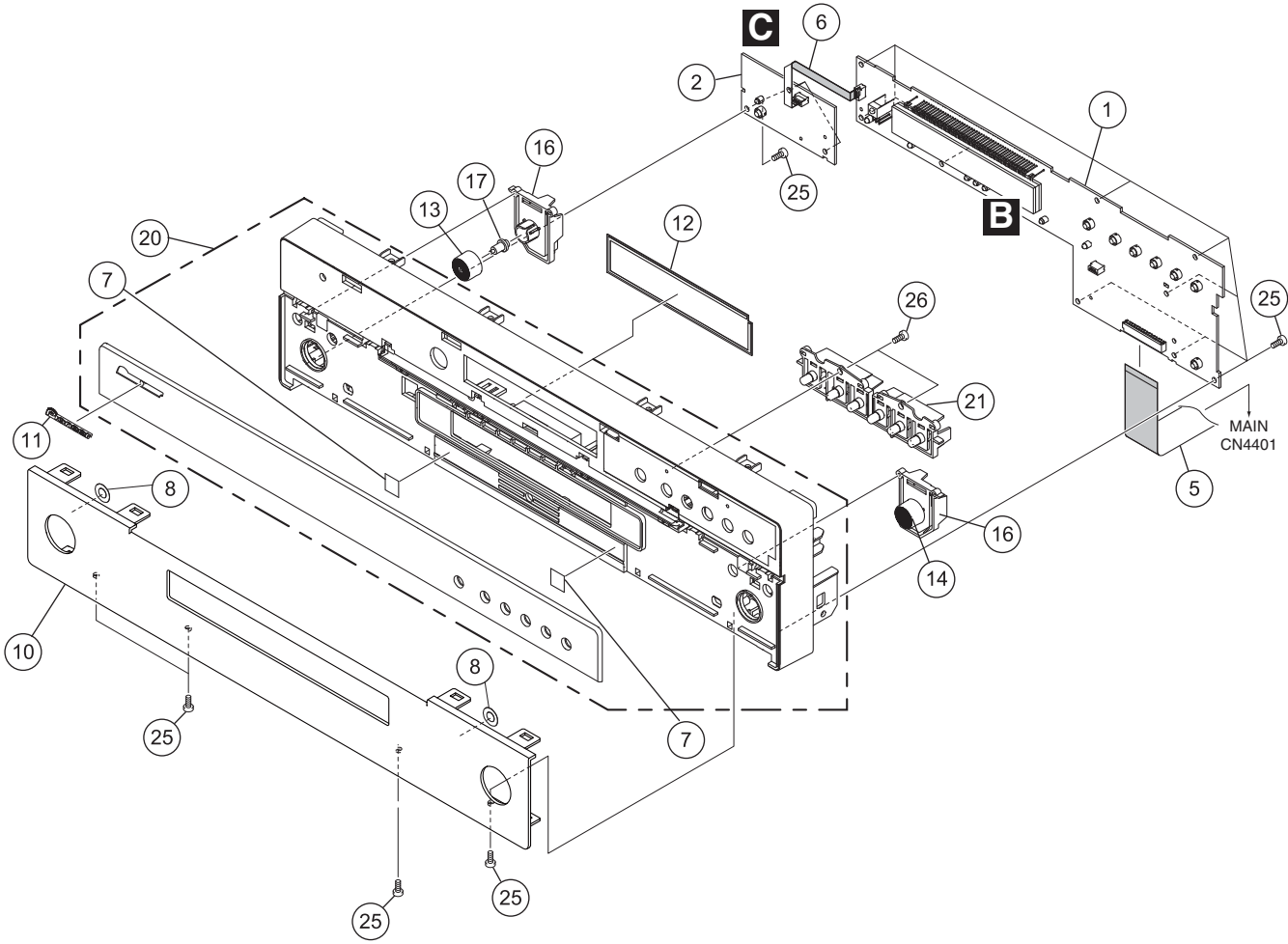

(1) FRONT PANEL SECTION PARTS LIST

<u>Mark No.</u>	<u>Description</u>	<u>Part No.</u>	<u>Mark No.</u>	<u>Description</u>	<u>Part No.</u>
1	FLKY Assy	VWG2625	16	Key Base PW/PL (ABS)	VNK6347
2	PSWB Assy	VWG2613	17	Key Lens (ABS)	VNK6350
3	•••••		18	•••••	
4	•••••		19	•••••	
5	Flexible Cable 30P	VDA2185	20	Panel Base Assy	See Contrast table (2)
6	Flexible Cable 5P	VDA2186	21	MAIN Key (ABS)	VNK6353
7	Spacer PB (PET)	VEC2633	22	•••••	
8	Fiber Washer	VEC2634	23	•••••	
9	•••••		24	•••••	
10	Front Cover (ABS)	See Contrast table (2)	25	Screw	BPZ30P080FBN
11	Name Plate B NEW (AL)	AAN7218	26	Screw	BPZ26P060FTC
12	FL Filter (PC)	VEC2604			
13	Key Top PW (ABS)	VNK6380			
14	Key Top PL (ABS)	VNK6381			
15	•••••				

(2) CONTRAST TABLE

BDP-51FD/WYXJ5, /WVXJ5, /WSXJ5, /TLXJ and BDP-51FD/WPWXJ are constructed the same except for the following:

Mark	No.	Symbol and Description	BDP-51FD /WYXJ5	BDP-51FD /WVXJ5	BDP-51FD /WSXJ5	BDP-51FD /TLXJ	BDP-51FD /WPWXJ
	10	Front Cover (ABS)	VNK6460	VNK6460	VNK6460	VNK6463	VNK6463
	20	Panel Base Assy	VXA2964	VXA2964	VXA2964	VXA2963	VXA2963

10. SCHEMATIC DIAGRAM

10.1 MAIN ASSY (1/10)(GUIDE PAGE)

Note: When ordering service parts, be sure to refer to "EXPLODED VIEWS AND PARTS LIST" or "ELECTRICAL PARTS LIST".

A-a 1/10

NOTE	
1..SERVICE MAIN ASSY	VXX3328
NSP 2..MAIN ASSY (BDP2.0)	VWV2375
2..ATAB ASSY (BDP2.0)	VWV2360

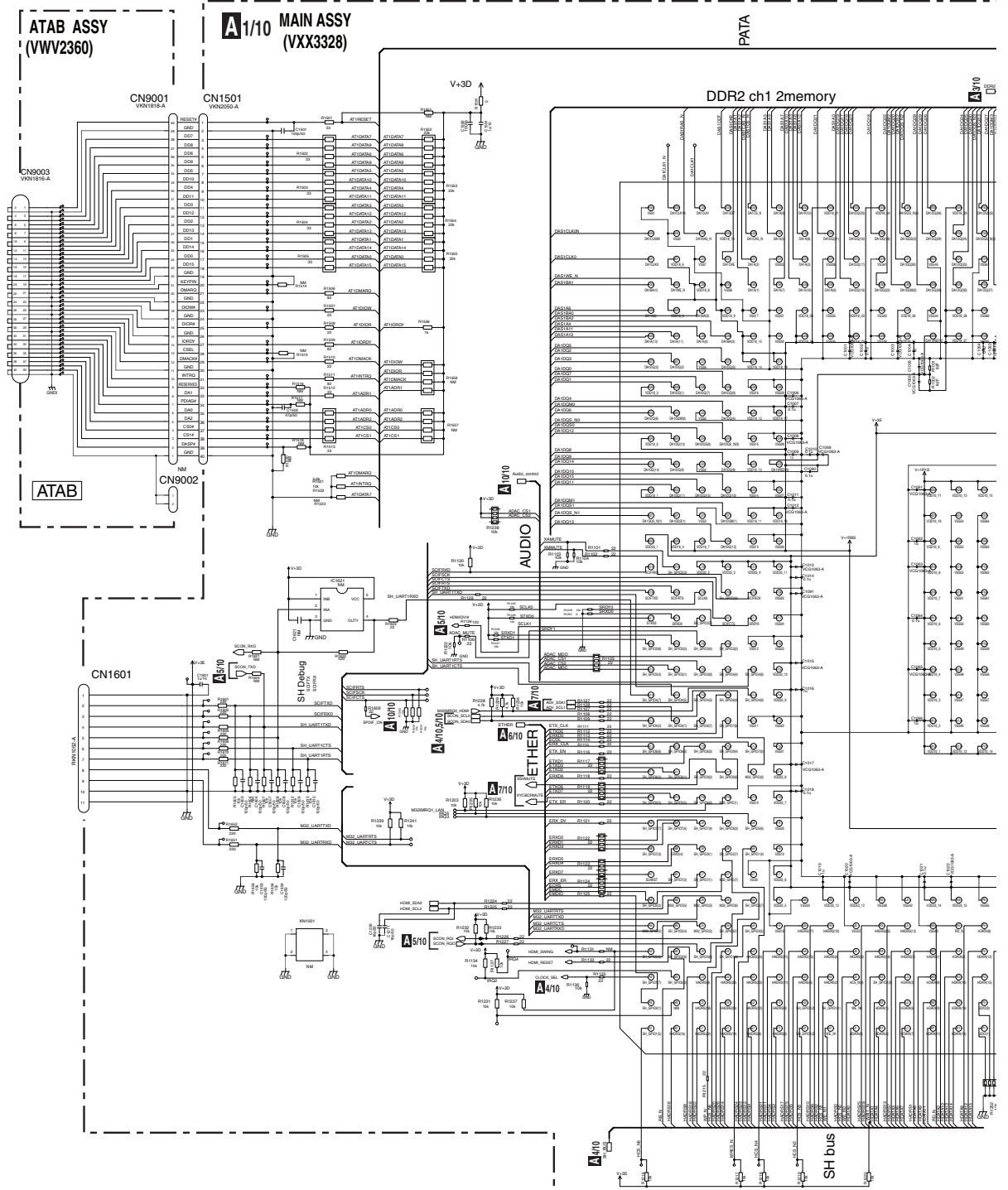
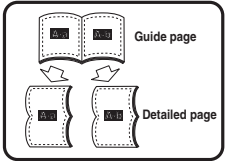
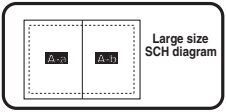

A 1/10

A-b 1/10

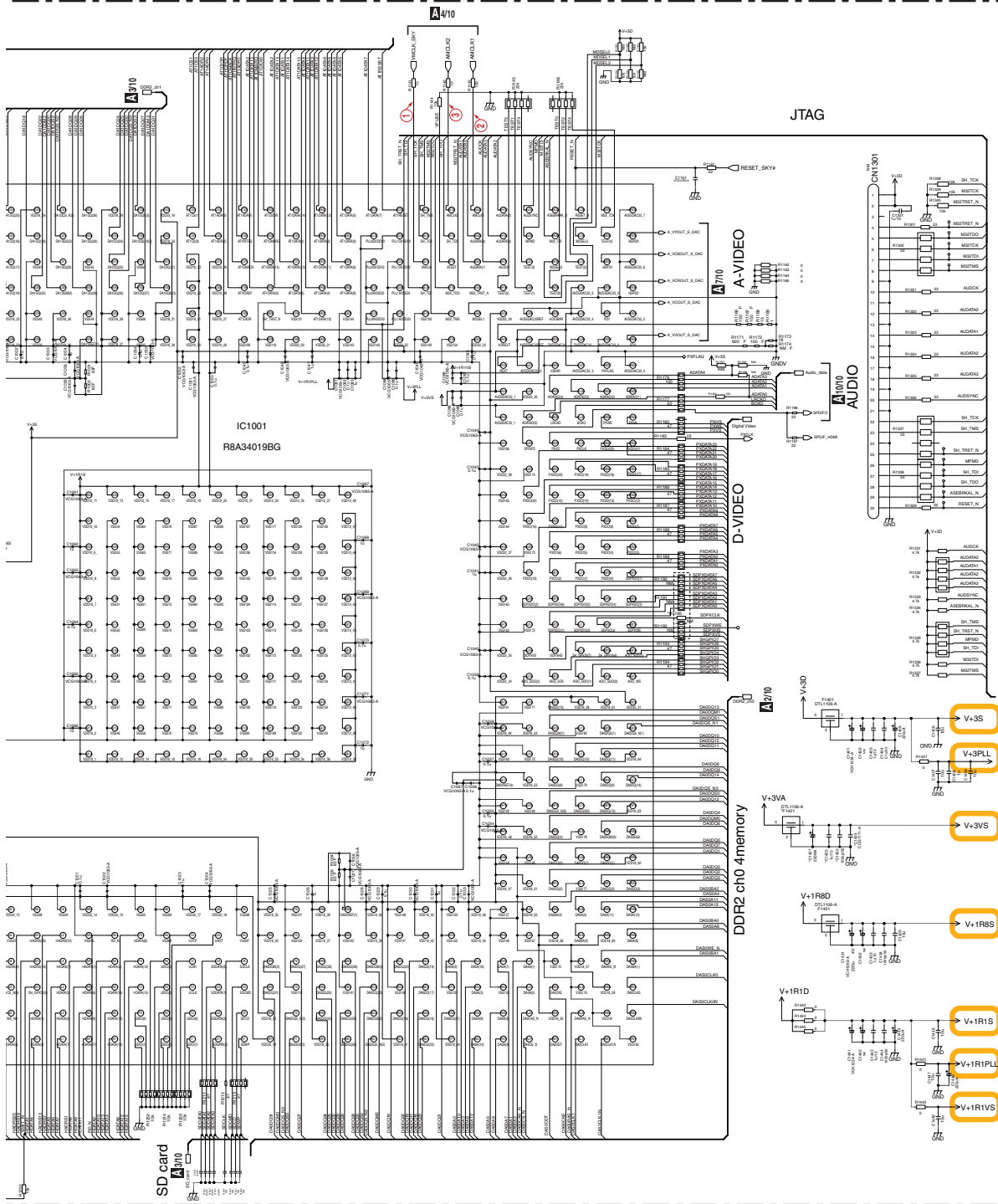

A

B

C

D

E

F

A-a A-b

A-b 1/10

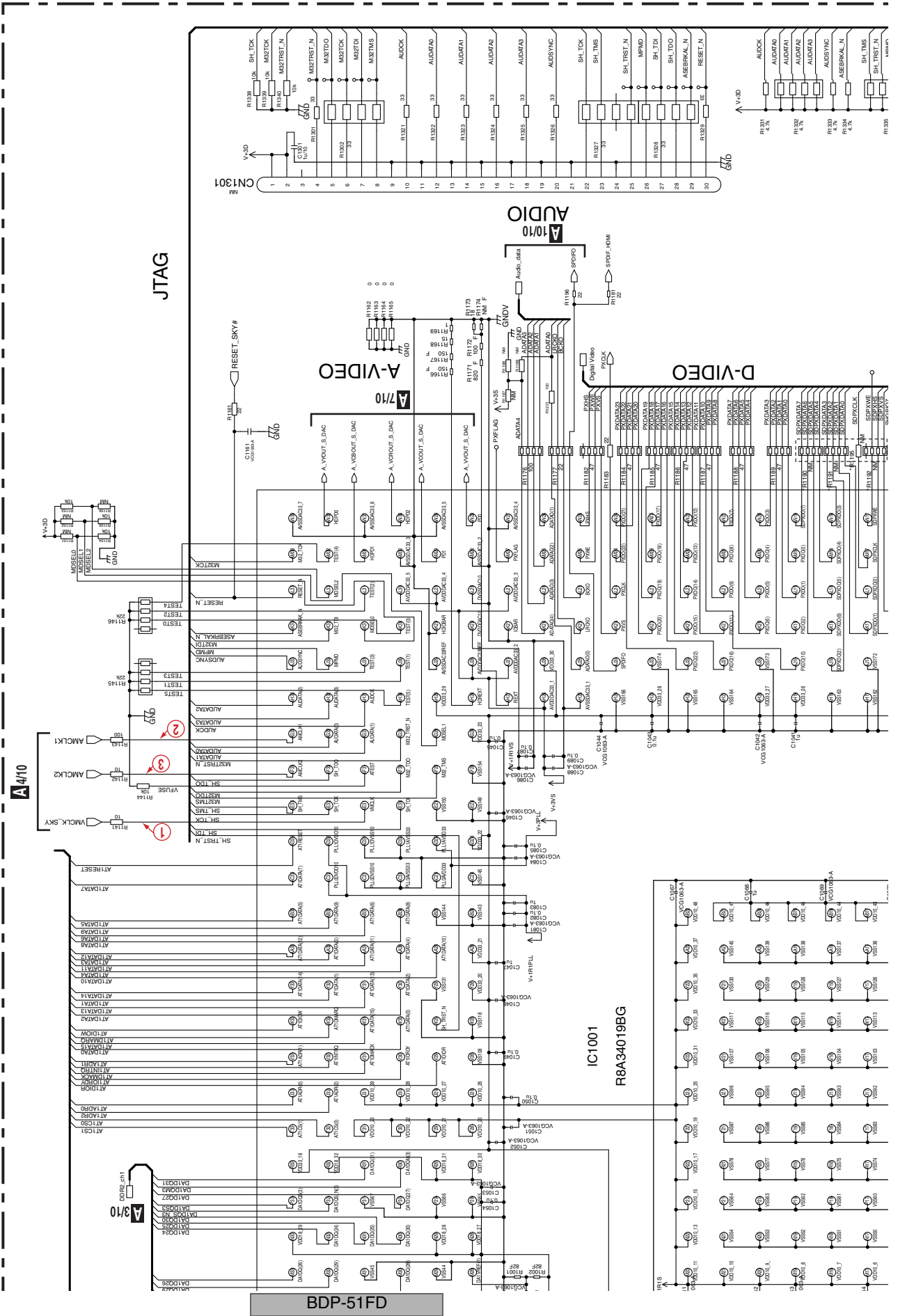

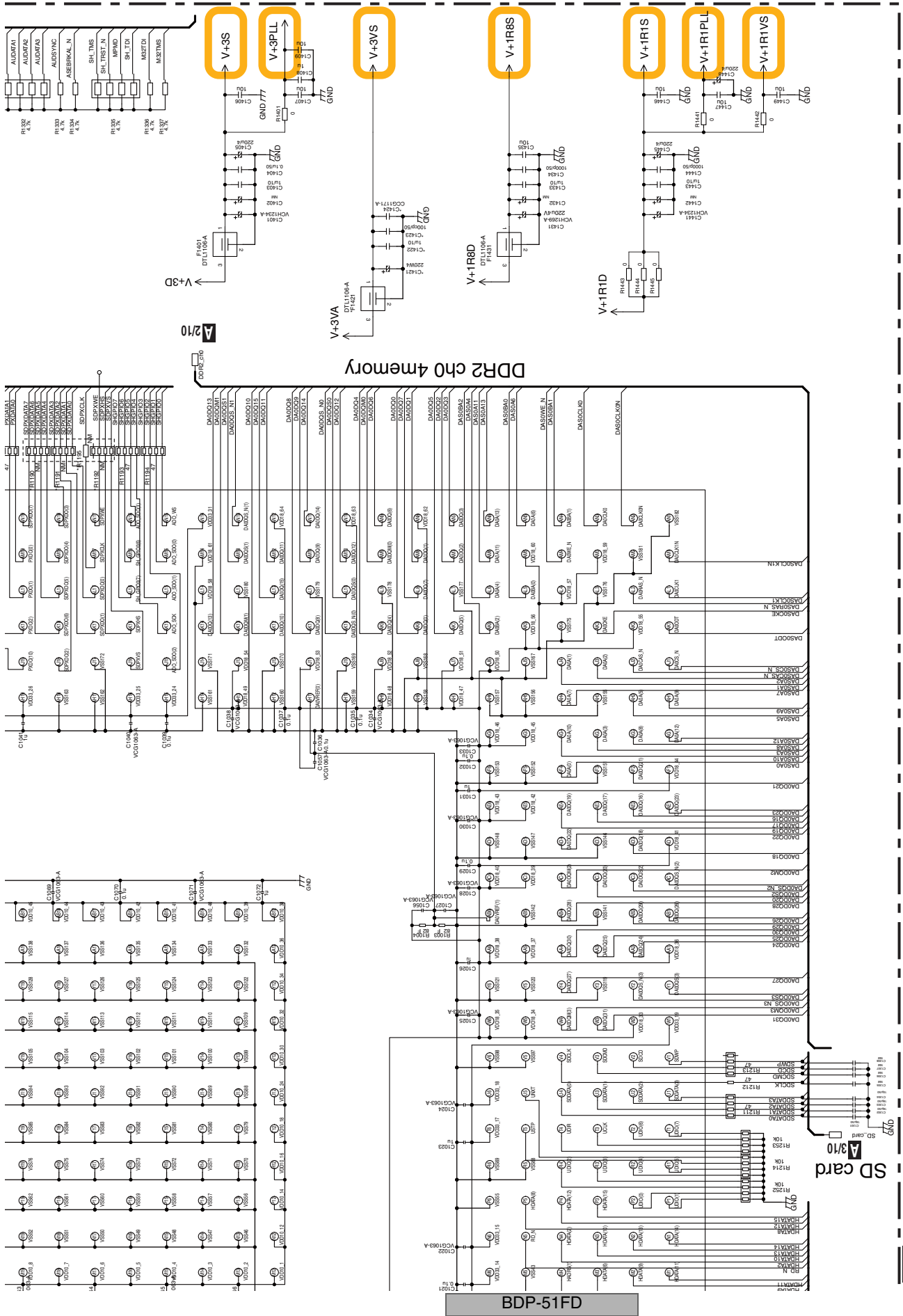

BDP-51FD

2/10

DDR2 ch0 4memory

SD card

3/10

ATAB ASSY (VWV2360)

MAIN ASSY (VXX3328) A1/10

PATA

CN9001 VKN1816-A

CN1501 VKN2050-A

DDR2 ch1 2memory

NOTE

1..SERVICE MAIN ASSY VXX3328
 2..MAIN ASSY (BDP2.0) VWV2375
 2..ATAB ASSY (BDP2.0) VWV2360

NSP

A-a A-b

A B C D E F

1 2 3 4

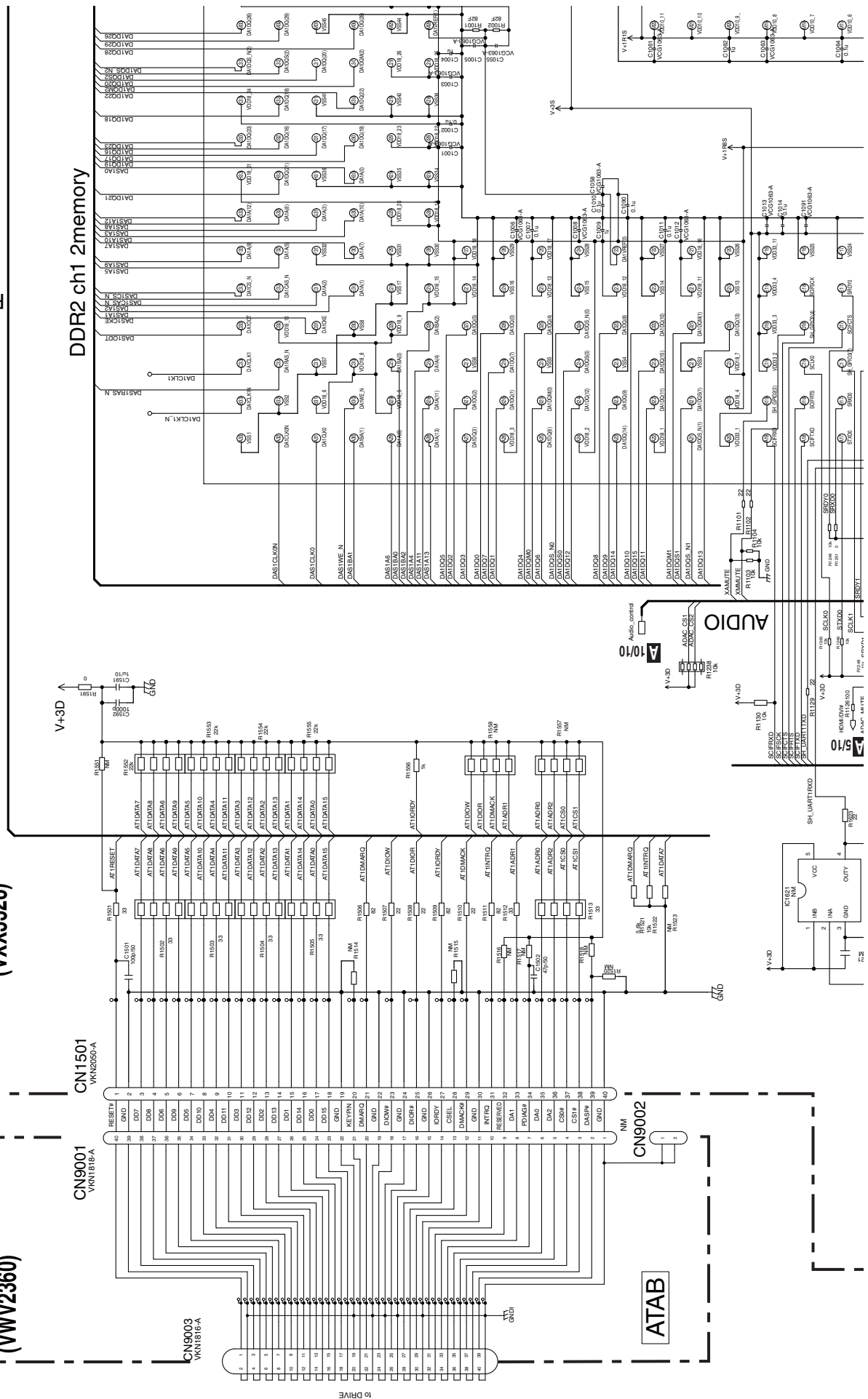

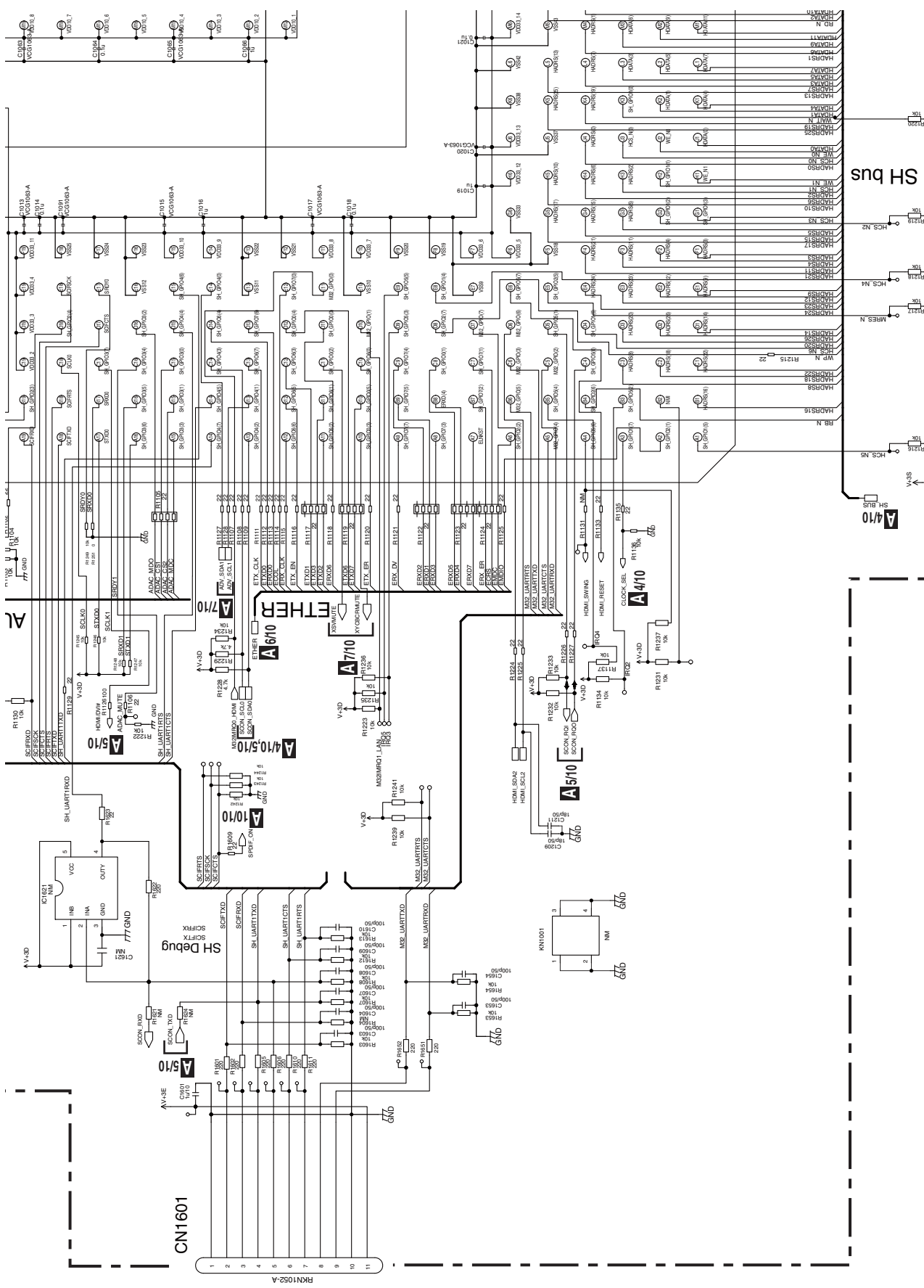

A-b 1/10

A-a A-b

BDP-51FD

A-a 1/10

10.2 MAIN ASSY (2/10)(GUIDE PAGE)

1

2

3

4

A

A-a 2/10

B

C

D

E

F

NOTE
 1..SERVICE MAIN ASSY VXX3328
 NSP VVV2375
 2..ATAB ASSY (BDP2.0) VVV2360

DDR2 ch0

A2/10 MAIN ASSY (VXX3328)

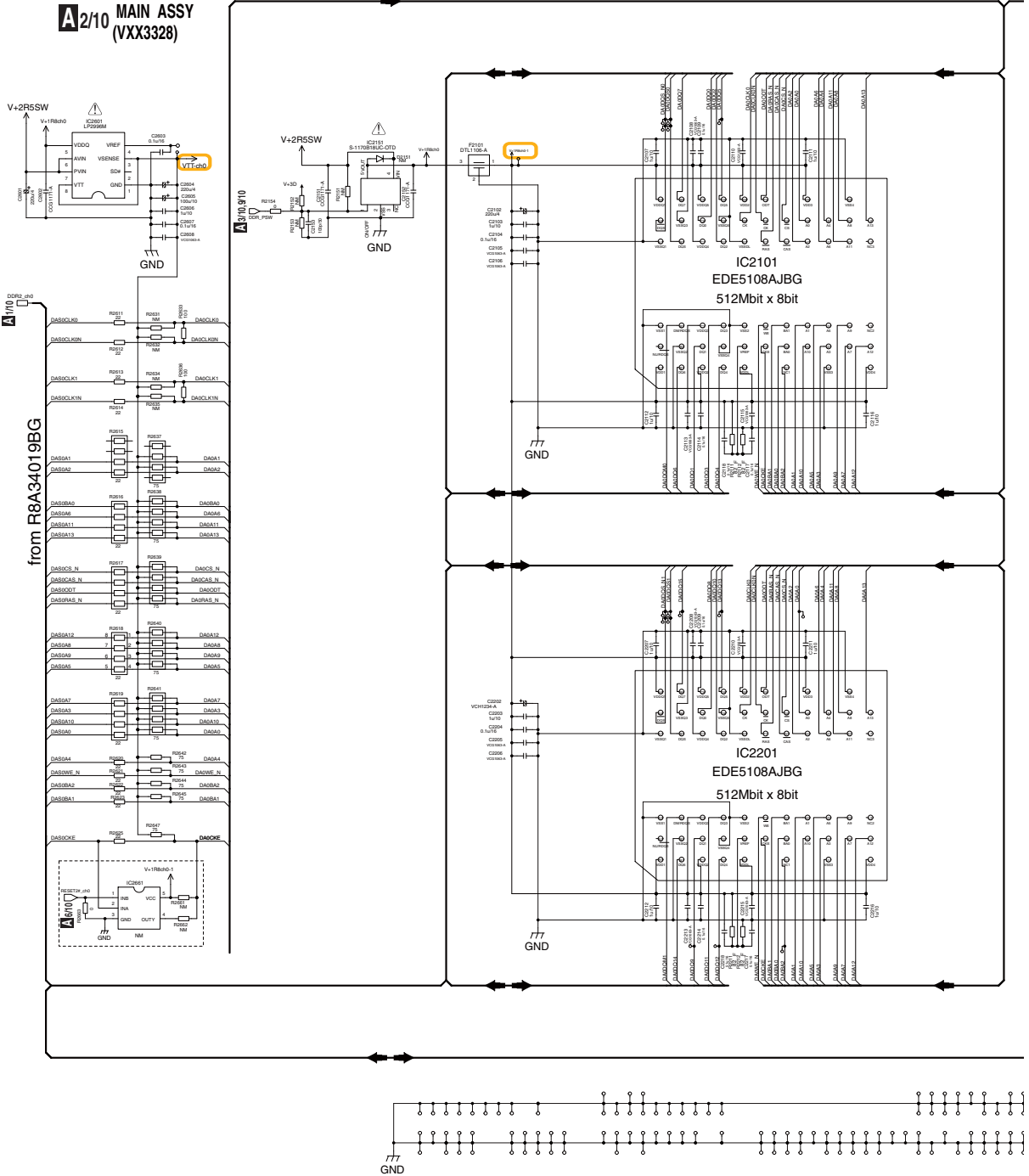

A2/10

1

2

3

4

A-b 2/10

DDR2 ch0

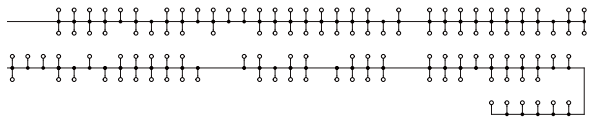
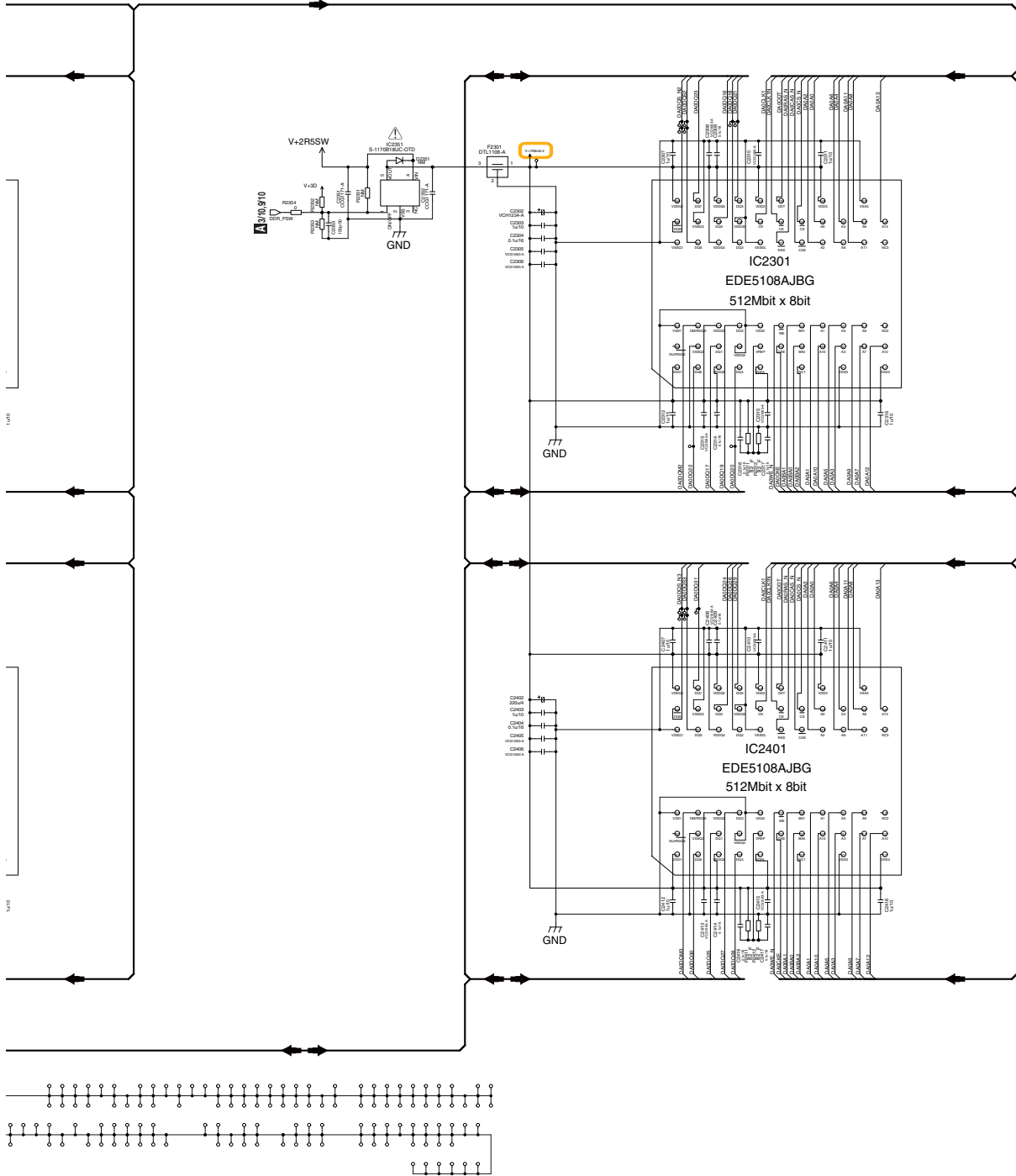

A
B
C
D
E
F

A

B

C

D

E

F

DDR2 ch0

A-a A-b

A-b 2/10

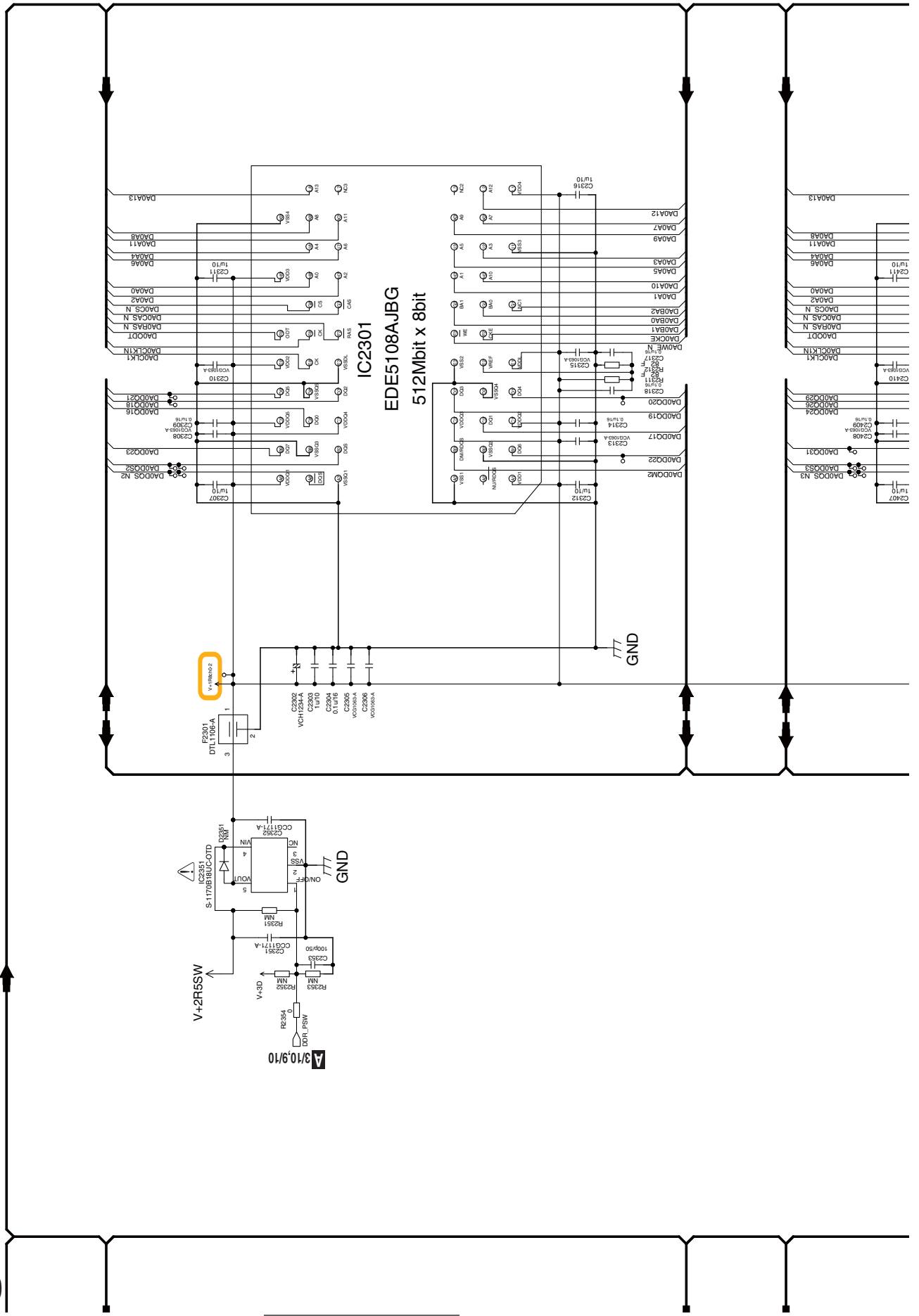

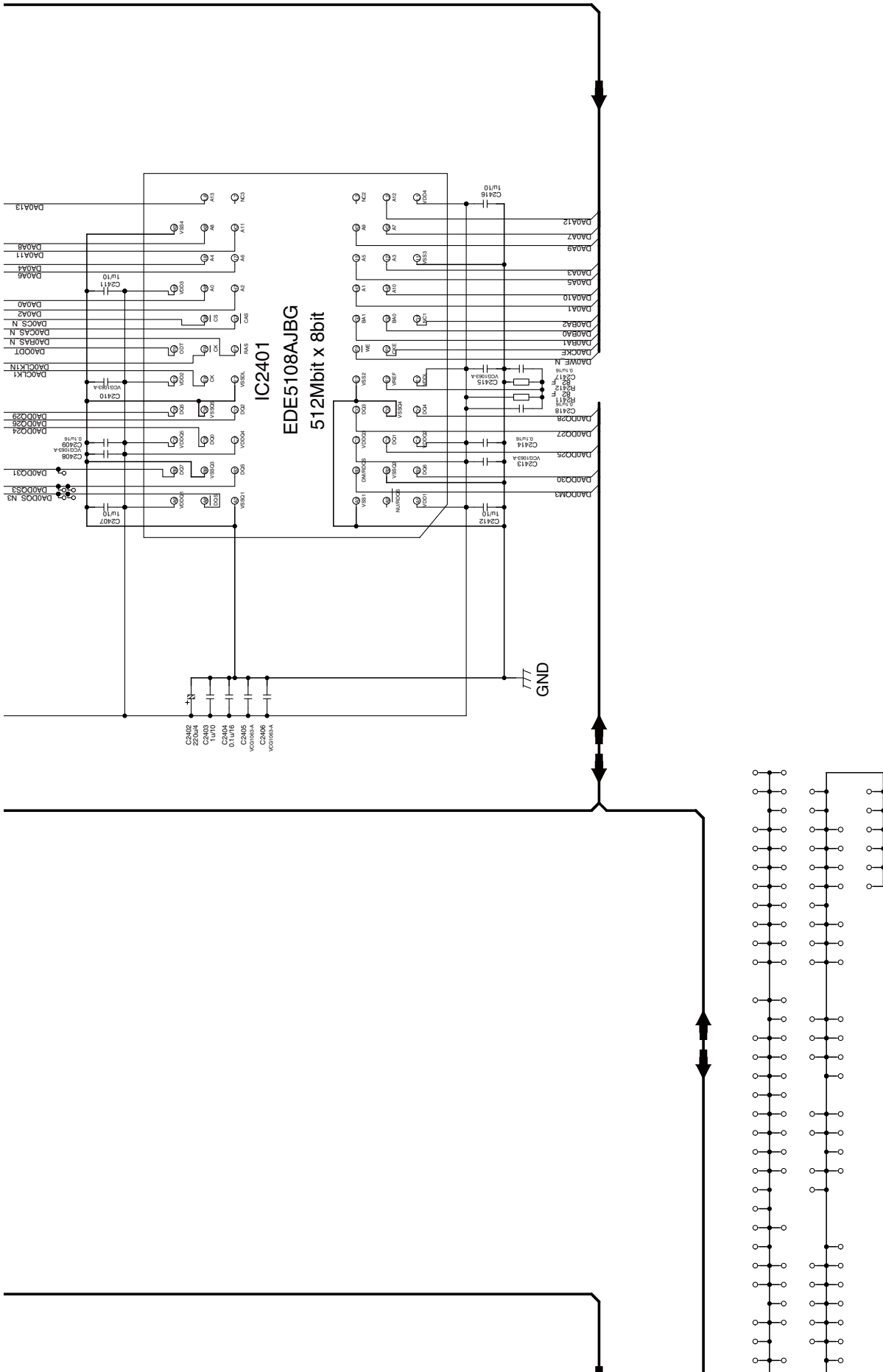

A-a

A-b 2/10

NOTE

- 1..SERVICE MAIN ASSY
- 2..MAIN ASSY (BDP2.0)
- 2..ATAB ASSY (BDP2.0)

- VXX3328
- VWV2375
- VWV2360

A-a A-b

DDR2 ch0

A 2/10 MAIN ASSY (VXX3328)

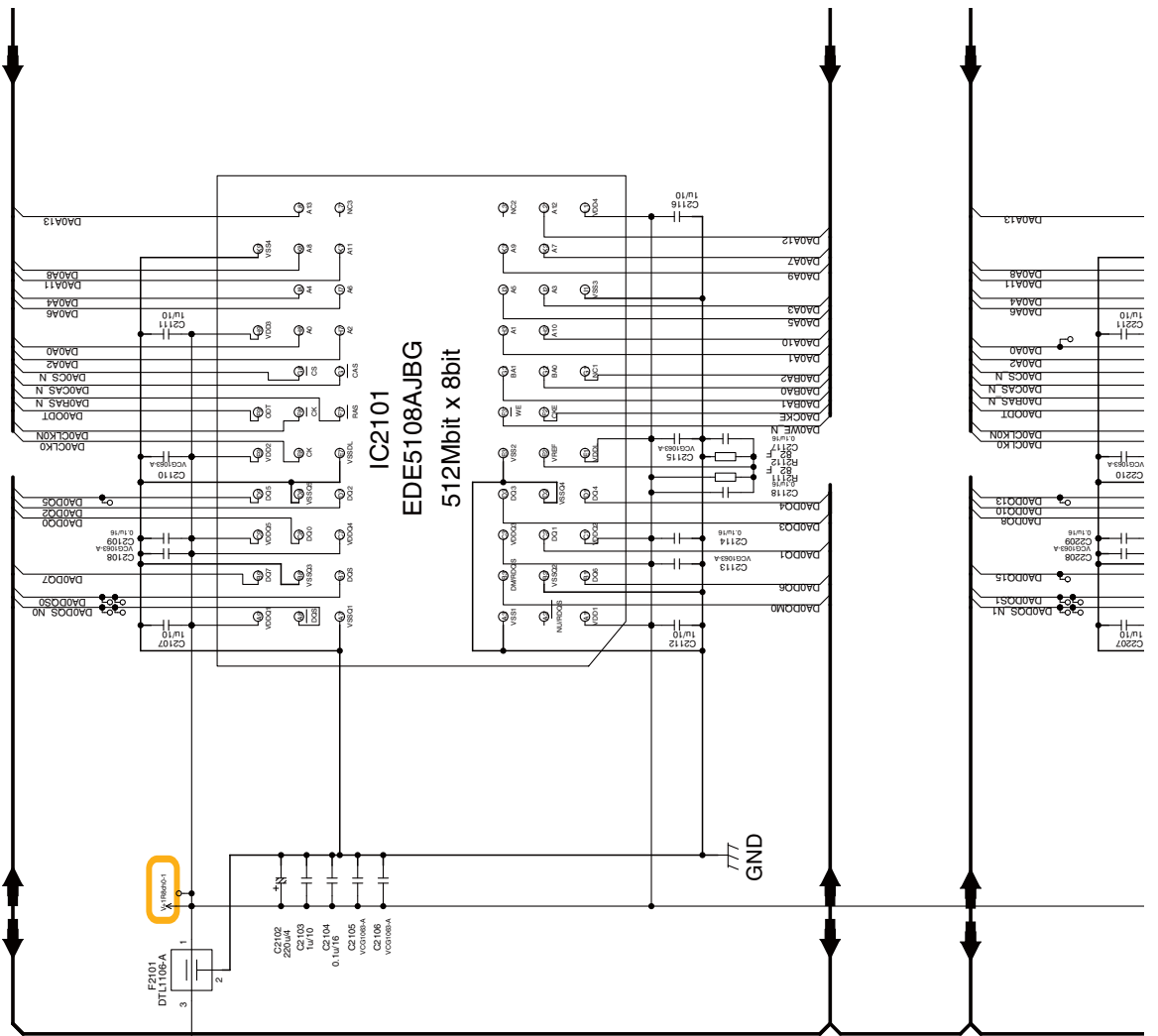
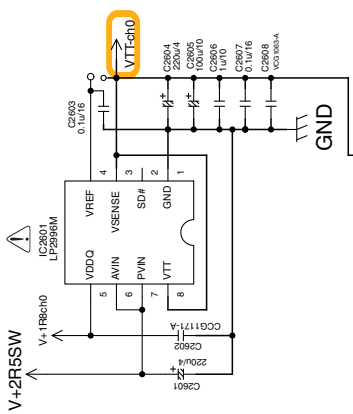

from R8A34019BG

1 2 3 4 A B C D E F

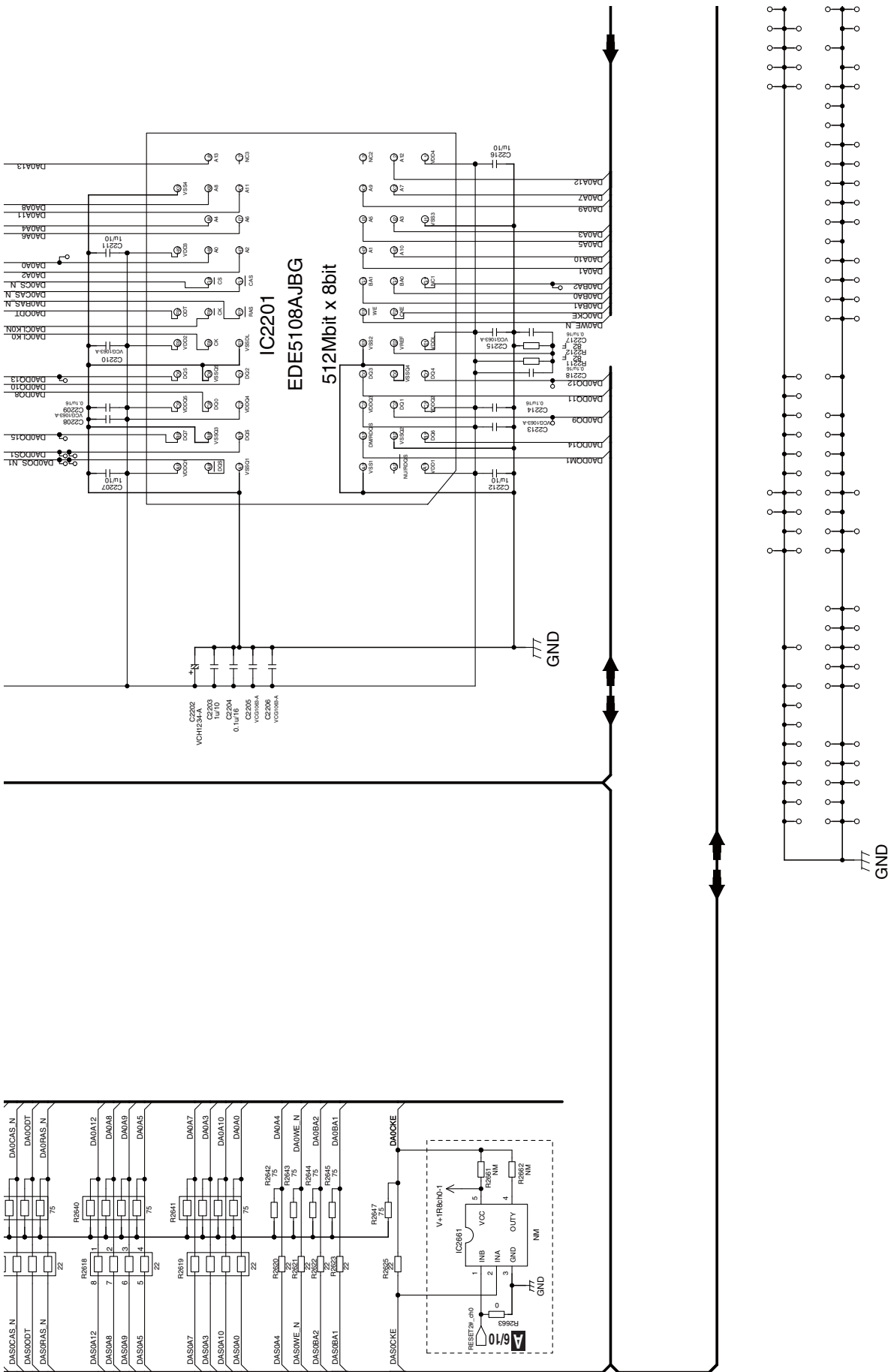

10.3 MAIN ASSY (3/10)

A3/10 MAIN ASSY (VXX3328)

NOTE

- | | |
|---------------------------|---------|
| 1..SERVICE MAIN ASSY | VXX3328 |
| NSP 2..MAIN ASSY (BDP2.0) | VWV2375 |
| 2..ATAB ASSY (BDP2.0) | VWV2360 |

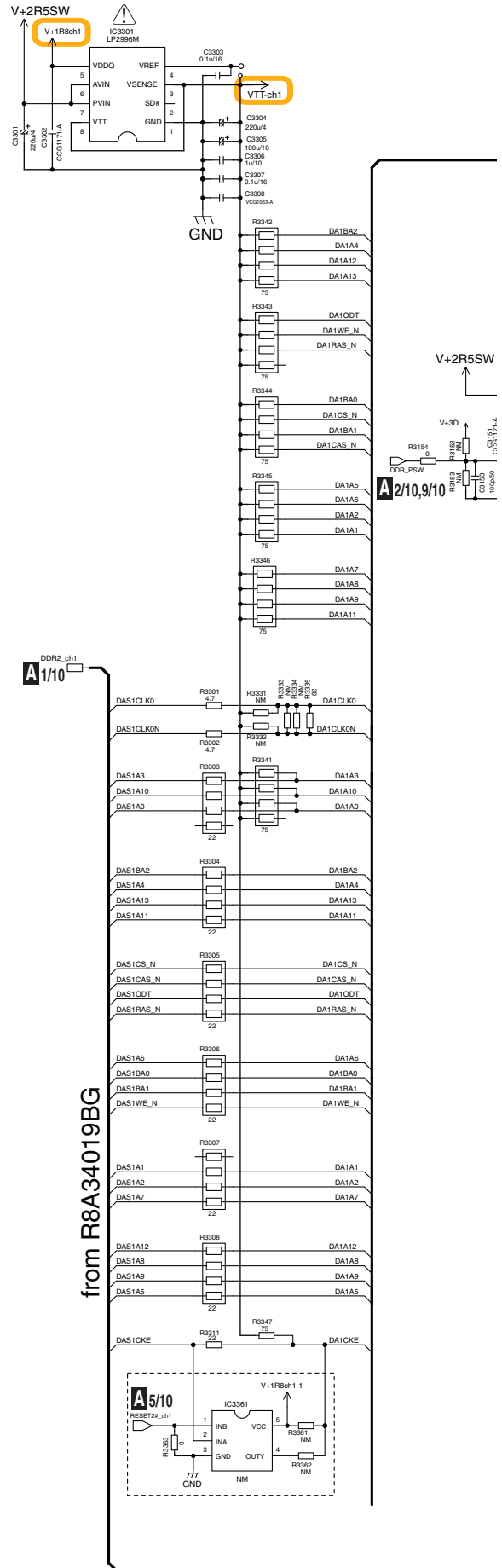
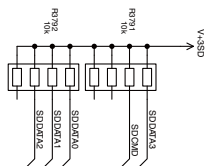
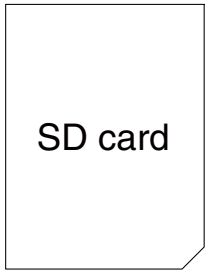
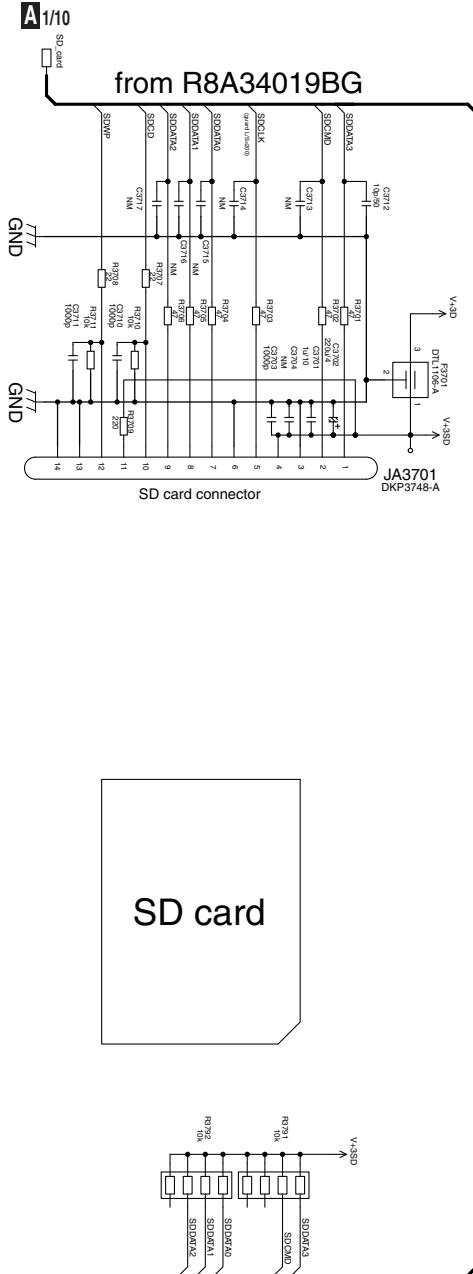

A3/10

DDR2 ch1

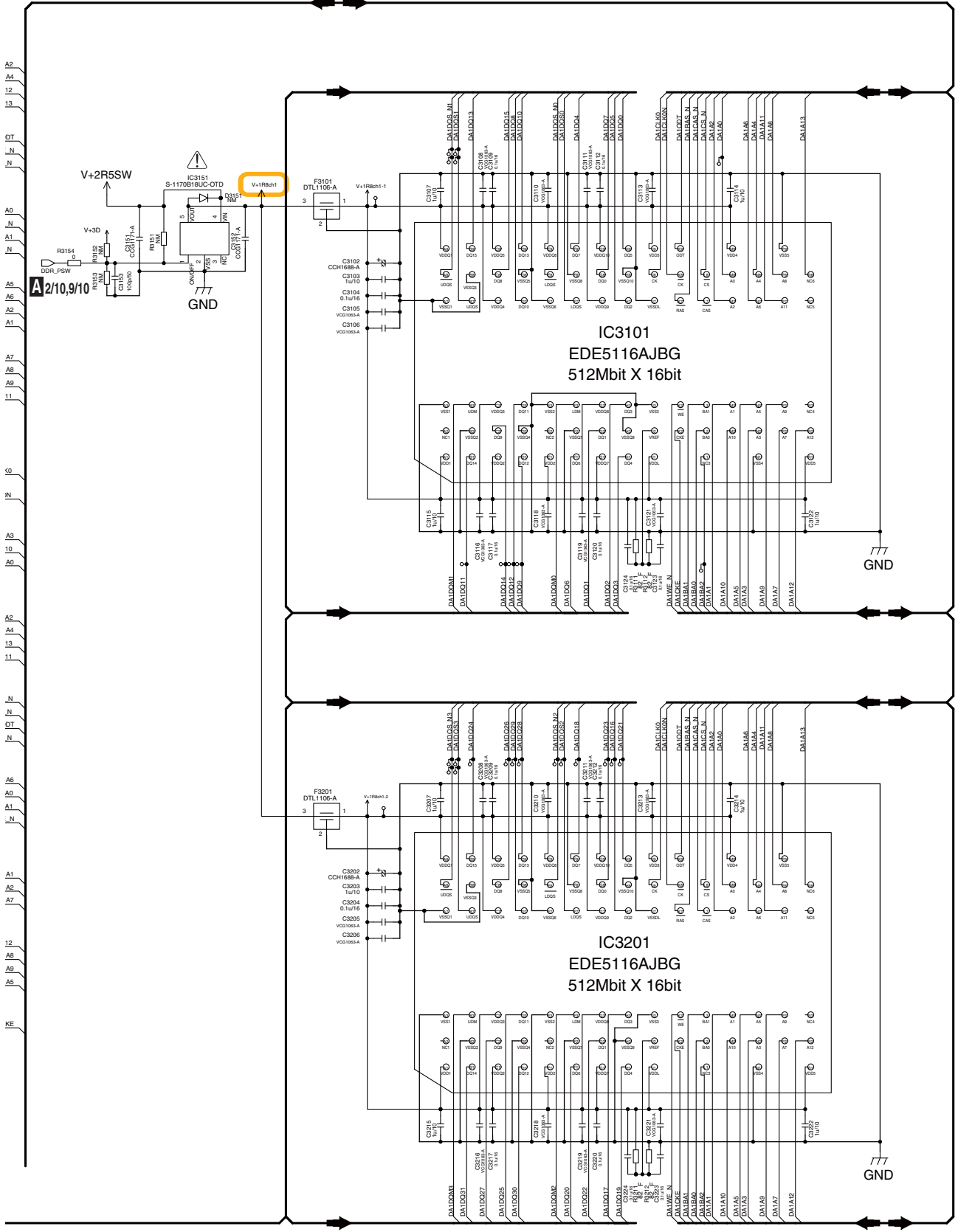

10.4 MAIN ASSY (4/10)

A4/10 MAIN ASSY (VXX3328)

NOTE		
1..SERVICE MAIN ASSY		VXX3328
NSP 2..MAIN ASSY (BDP2.0)		VWV2375
2..ATAB ASSY (BDP2.0)		VWV2360

Clock Generator

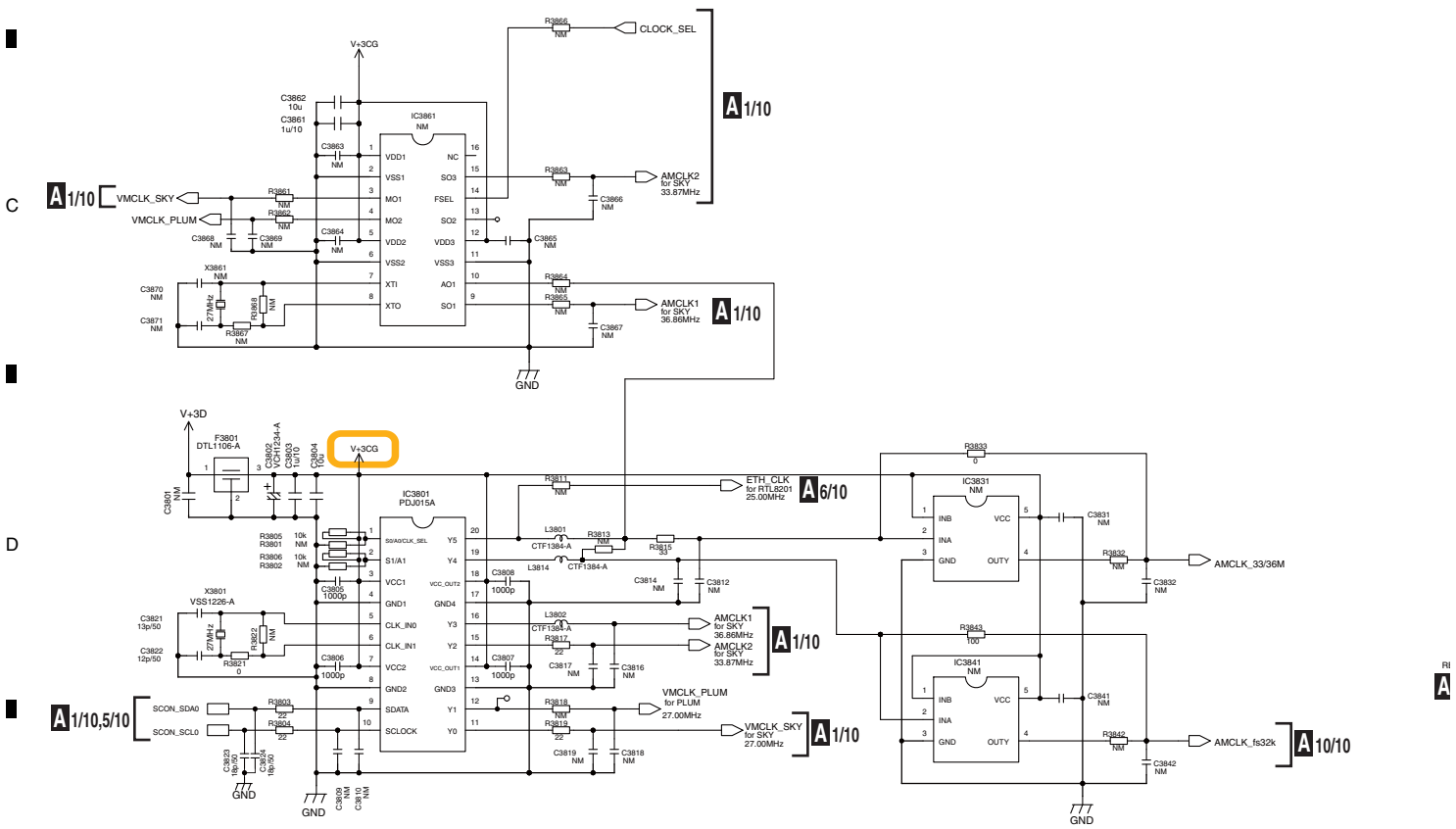

Nor FLASH

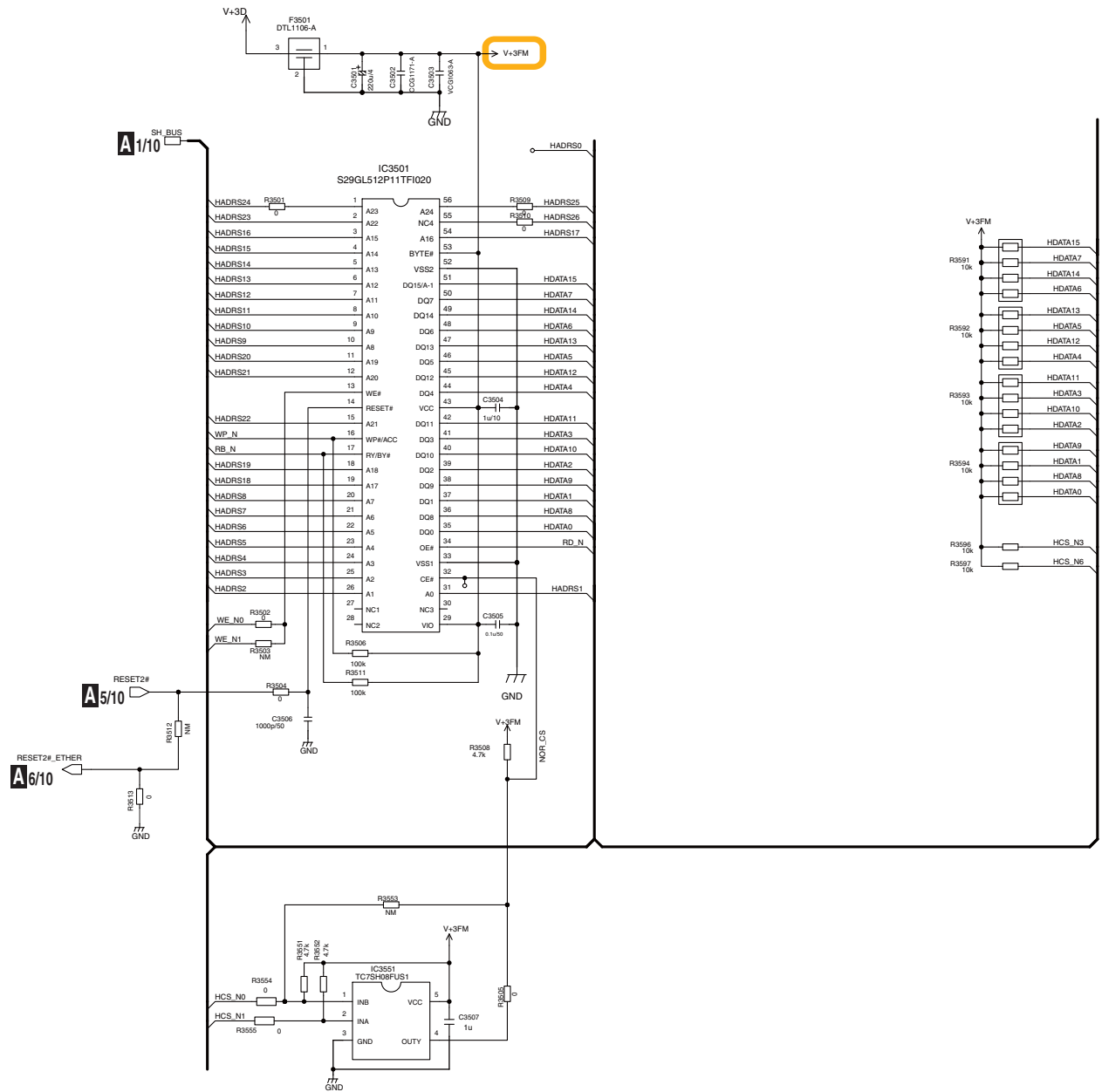

10.5 MAIN ASSY (5/10)

A5/10 MAIN ASSY (VXX3328)

NOTE		
1..SERVICE MAIN ASSY		VXX3328
NSP 2..MAIN ASSY (BDP2.0)		VVV2375
2..ATAB ASSY (BDP2.0)		VVV2360

SUB-CON

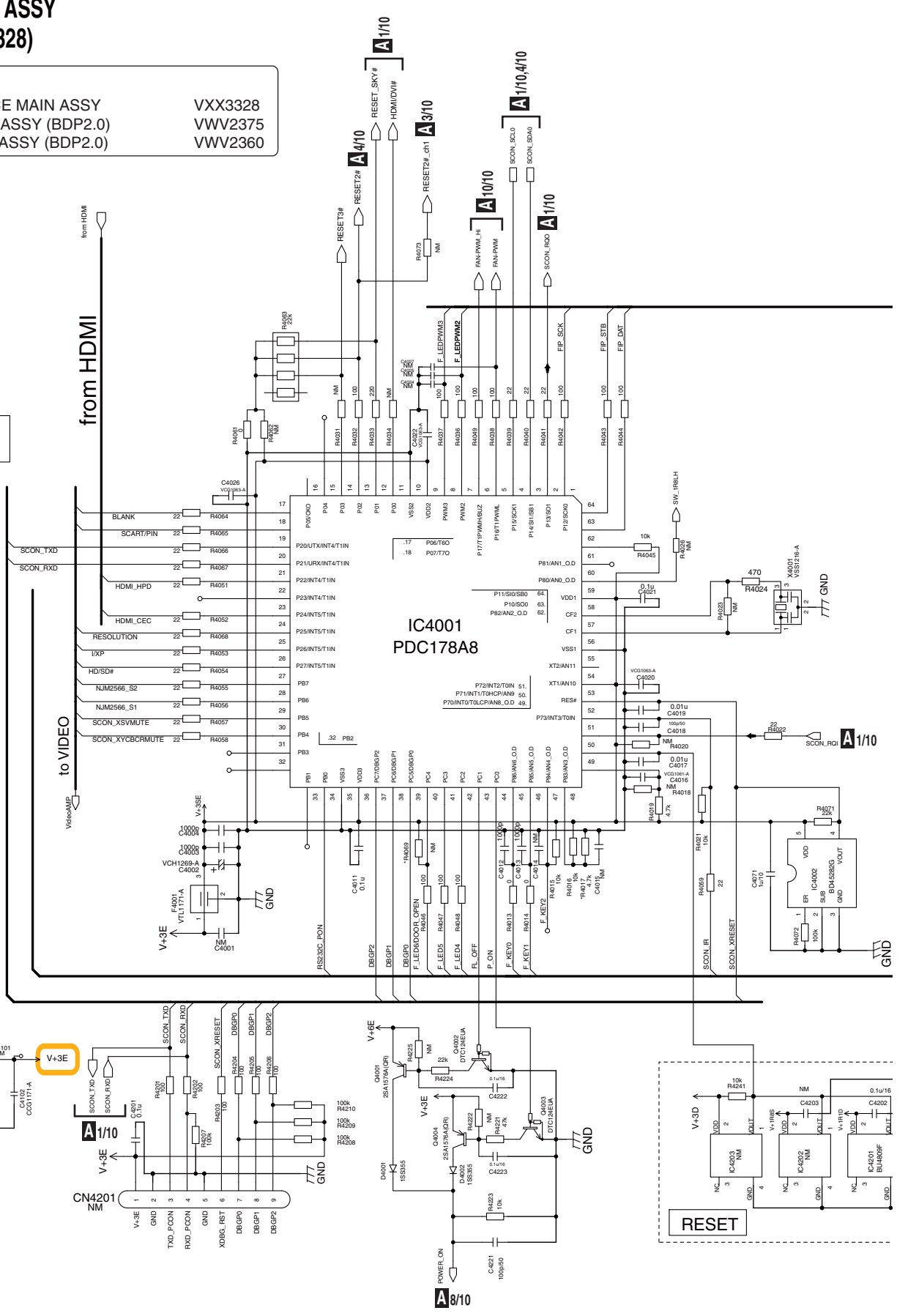

RESET

A5/10

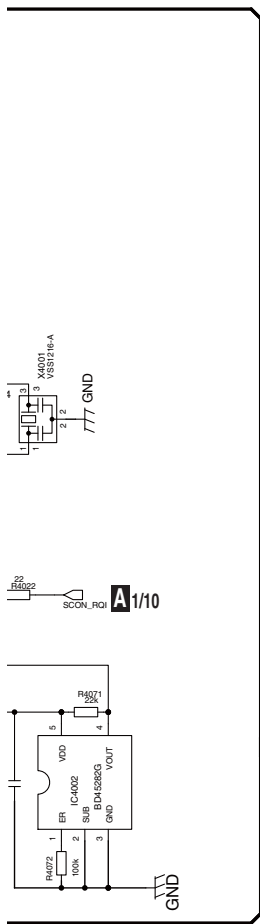

A/10

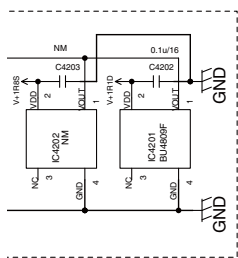

B CN1

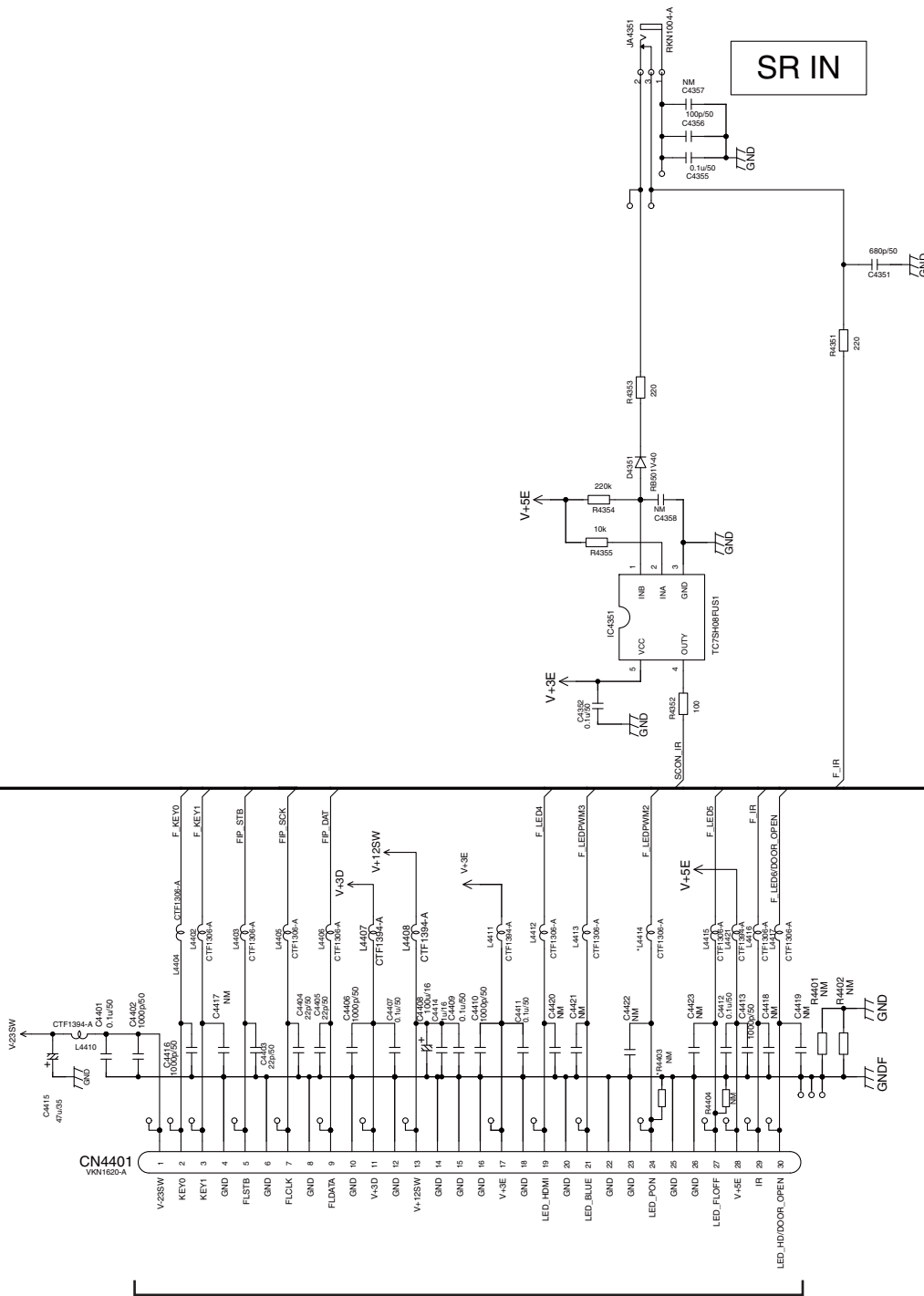

SR IN

BDP-51FD

A/5/10

10.6 MAIN ASSY (6/10)

1 2 3 4

A 6/10 MAIN ASSY (VXX3328)

NOTE		
NSP	1..SERVICE MAIN ASSY	VXX3328
	2..MAIN ASSY (BDP2.0)	VWV2375
	2..ATAB ASSY (BDP2.0)	VWV2360

Ether

A 1/10 ETHER

B

C

D

E

F

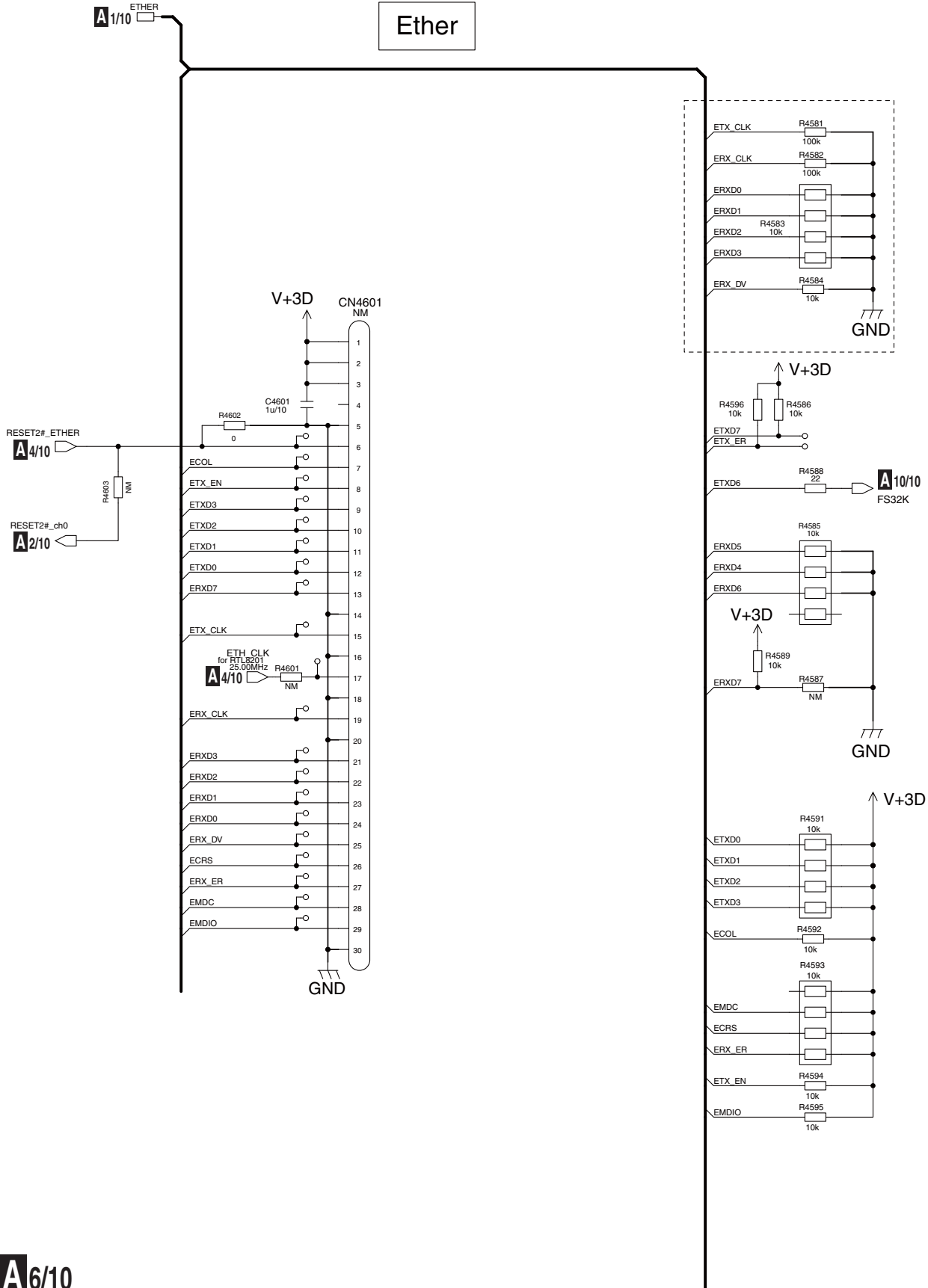

A 6/10

1 2 3 4

HDMI

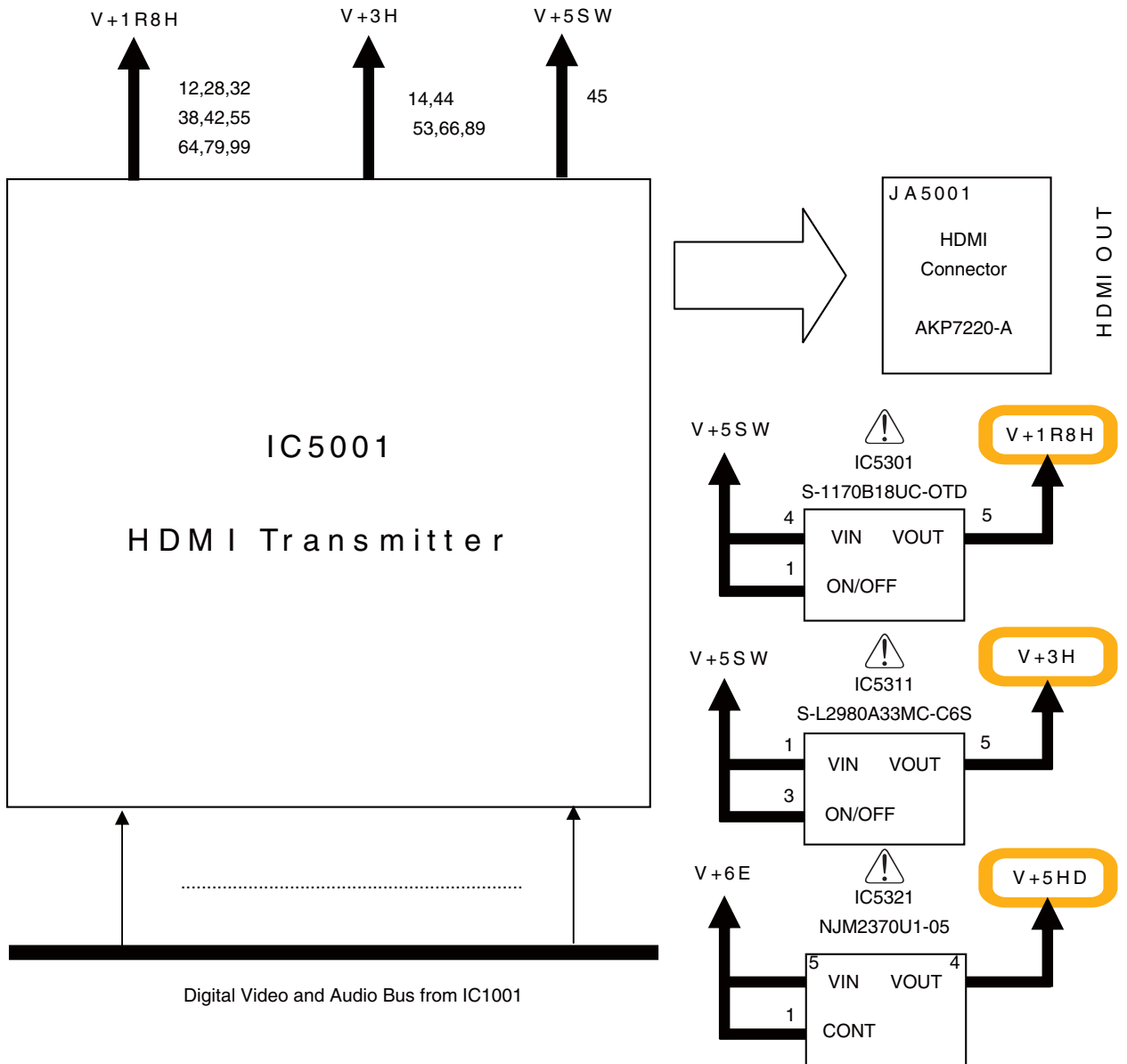

10.7 MAIN ASSY (7/10)

A 7/10 MAIN ASSY (VXX3328)

NOTE

NSP	1..SERVICE MAIN ASSY	VXX3328
	2..MAIN ASSY (BDP2.0)	VWV2375
	2..ATAB ASSY (BDP2.0)	VWV2360

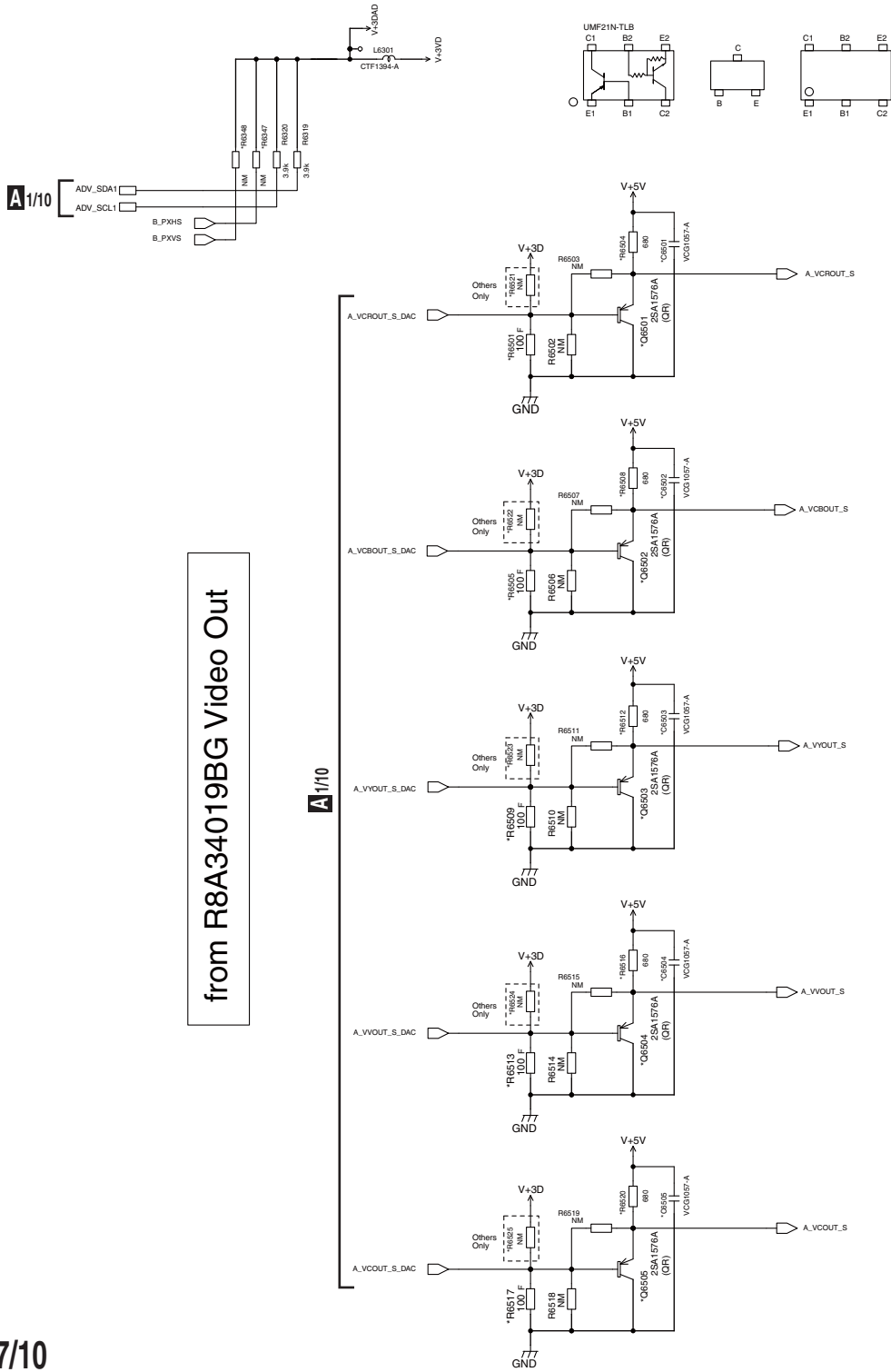

from R8A34019BG Video Out

A 1/10

VIDEO AMP

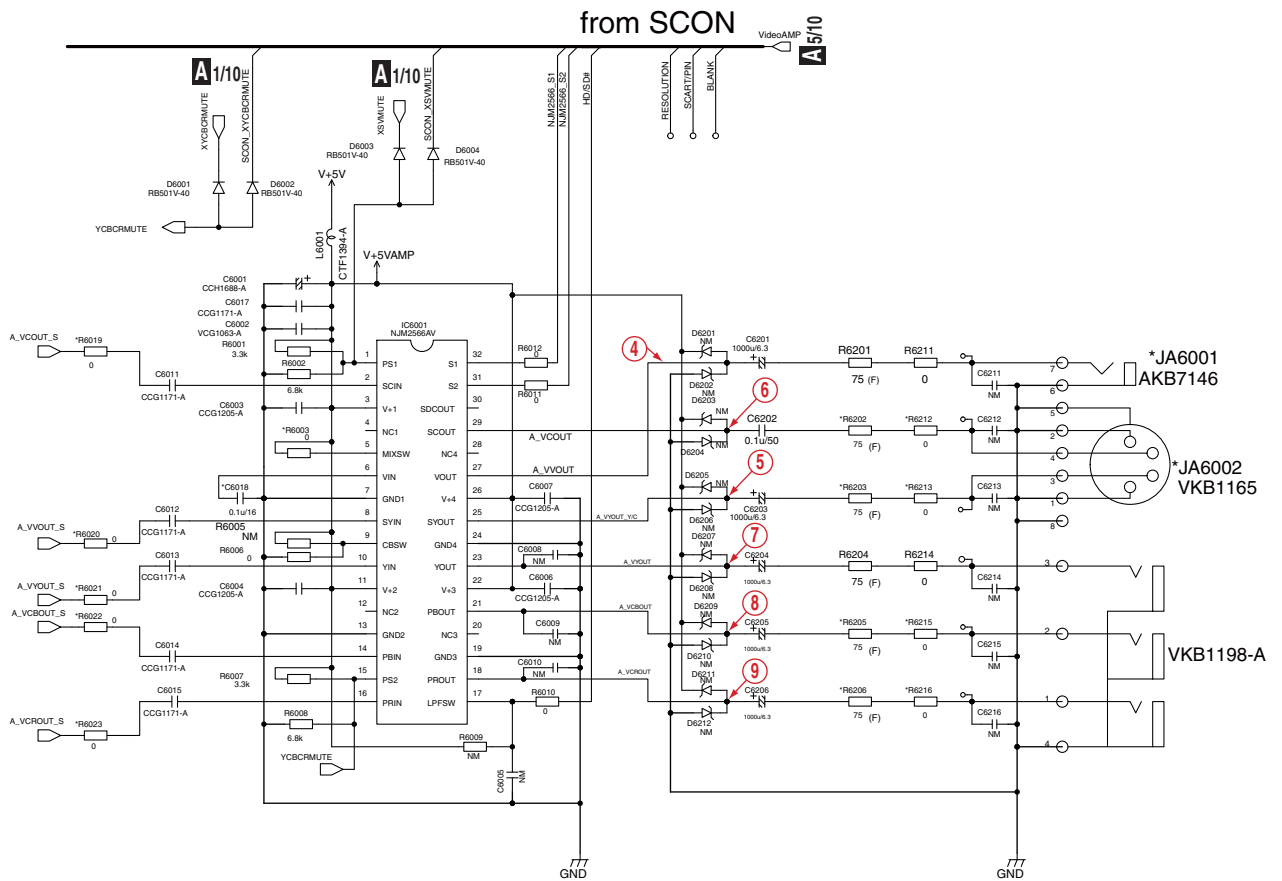

10.8 MAIN ASSY (8/10)

A 8/10 MAIN ASSY (VXX3328)

NOTE		
NSP	1..SERVICE MAIN ASSY	VXX3328
	2..MAIN ASSY (BDP2.0)	VWV2375
	2..ATAB ASSY (BDP2.0)	VWV2360

from SYPS

A
B
C
D
E
F

G CN201

G CN202

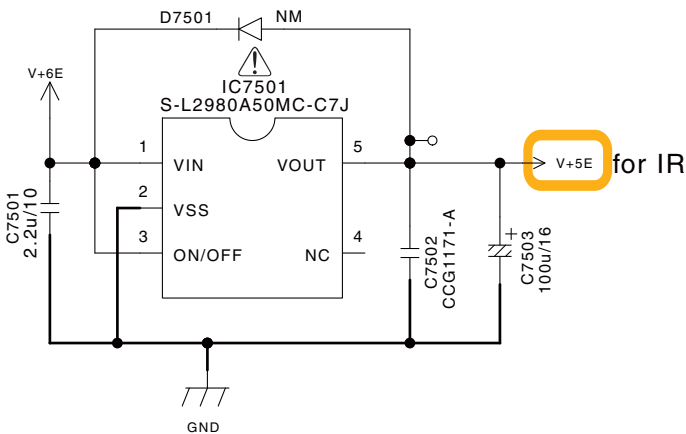
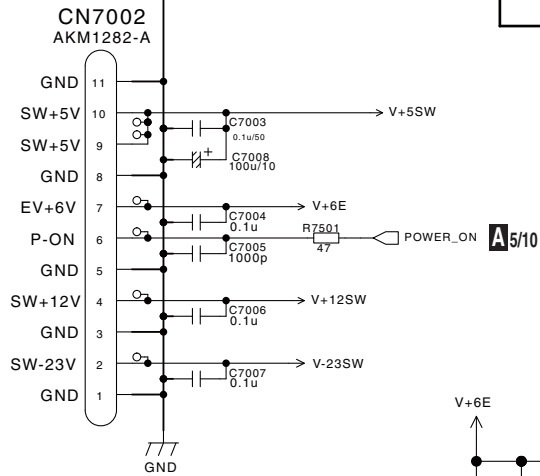
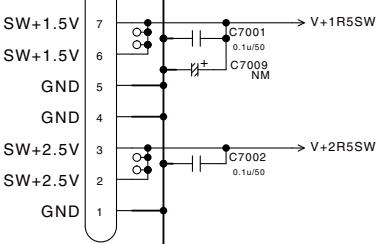
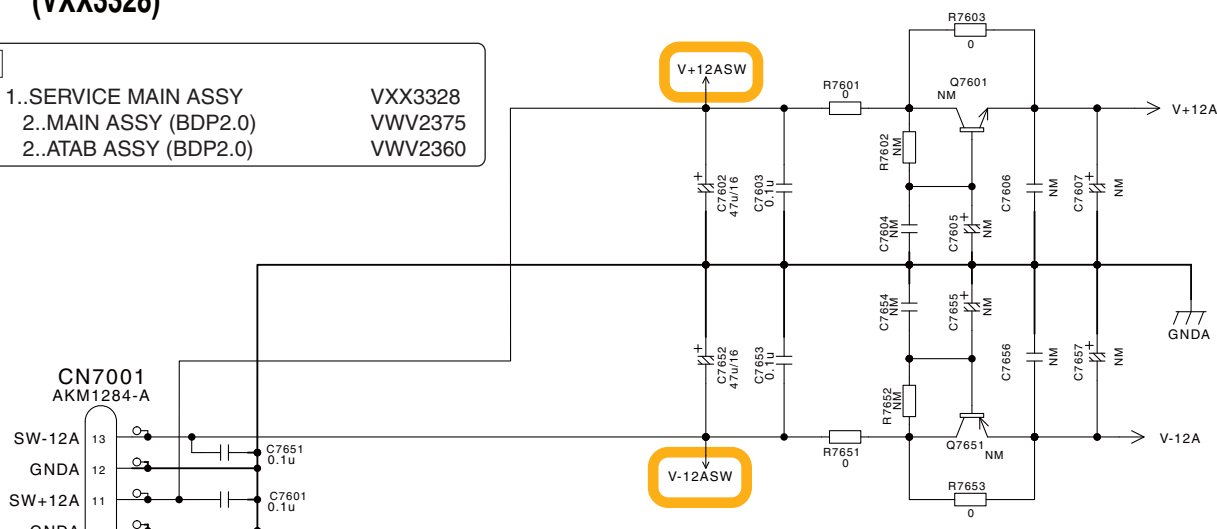

Regulator

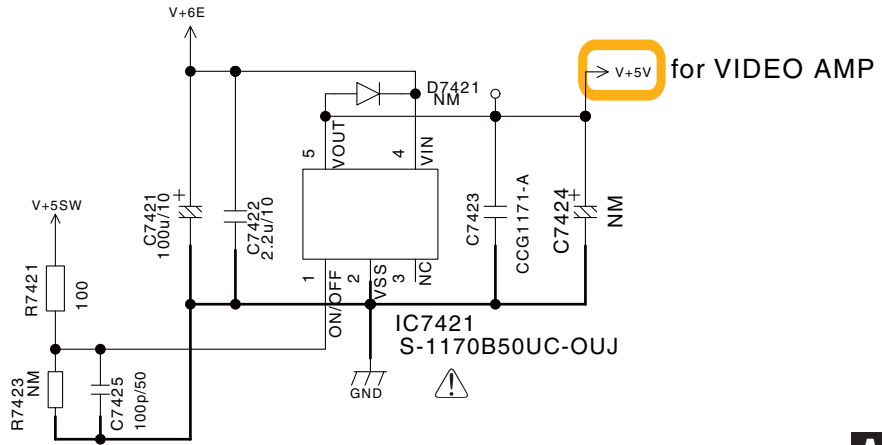

10.9 MAIN ASSY (9/10)

A9/10 MAIN ASSY (VXX3328)

NOTE

1..SERVICE MAIN ASSY	VXX3328
NSP 2..MAIN ASSY (BDP2.0)	VWV2375
2..ATAB ASSY (BDP2.0)	VWV2360

Regulator

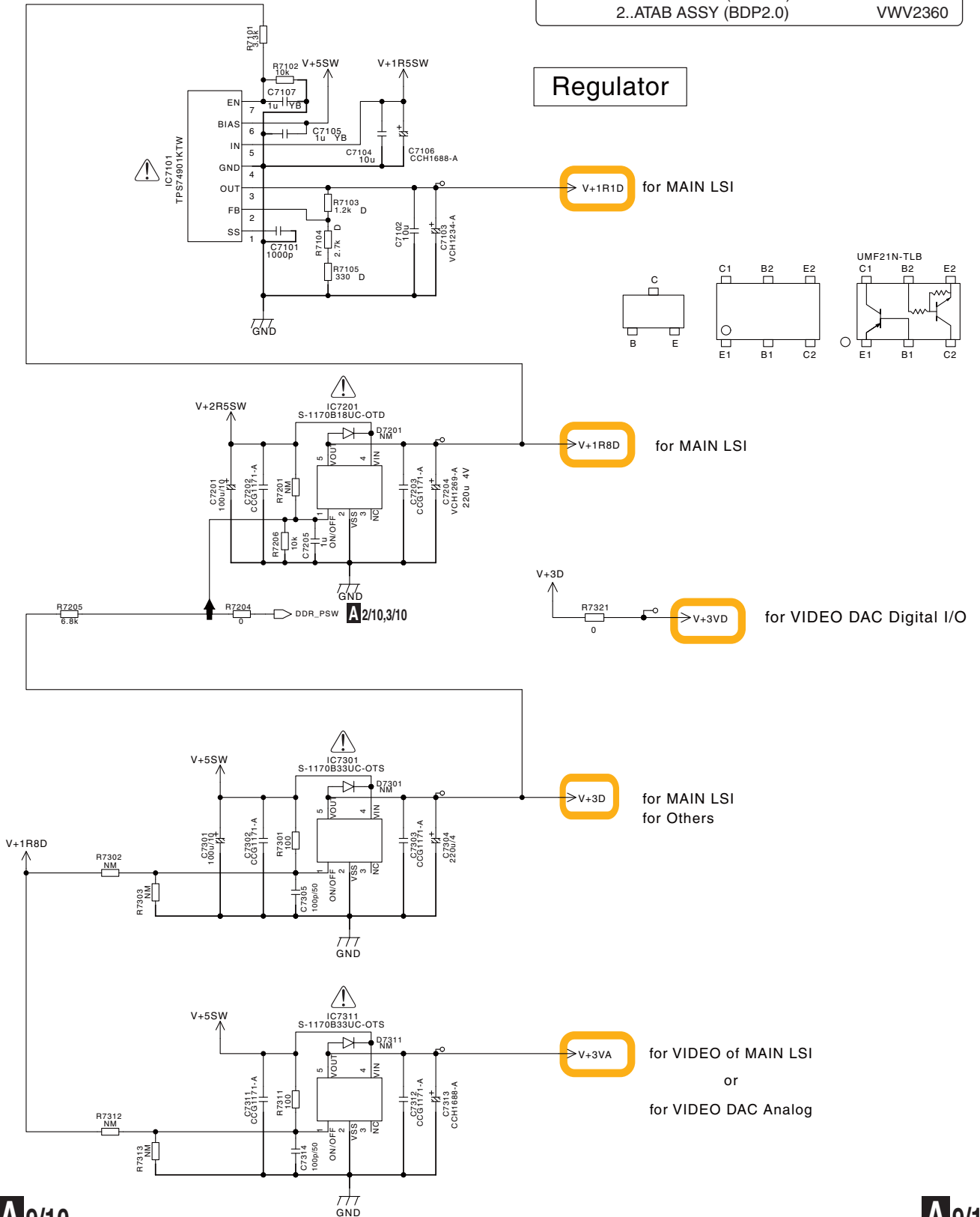

10.10 MAIN ASSY (10/10)(GUIDE PAGE)

A-a 10/10

A10/10 MAIN ASSY
(VXX3328)

NOTE	
1..SERVICE MAIN ASSY	VXX3328
2..MAIN ASSY (BDP2.0)	VWV2375
2..ATAB ASSY (BDP2.0)	VWV2360

AUDIO Digital

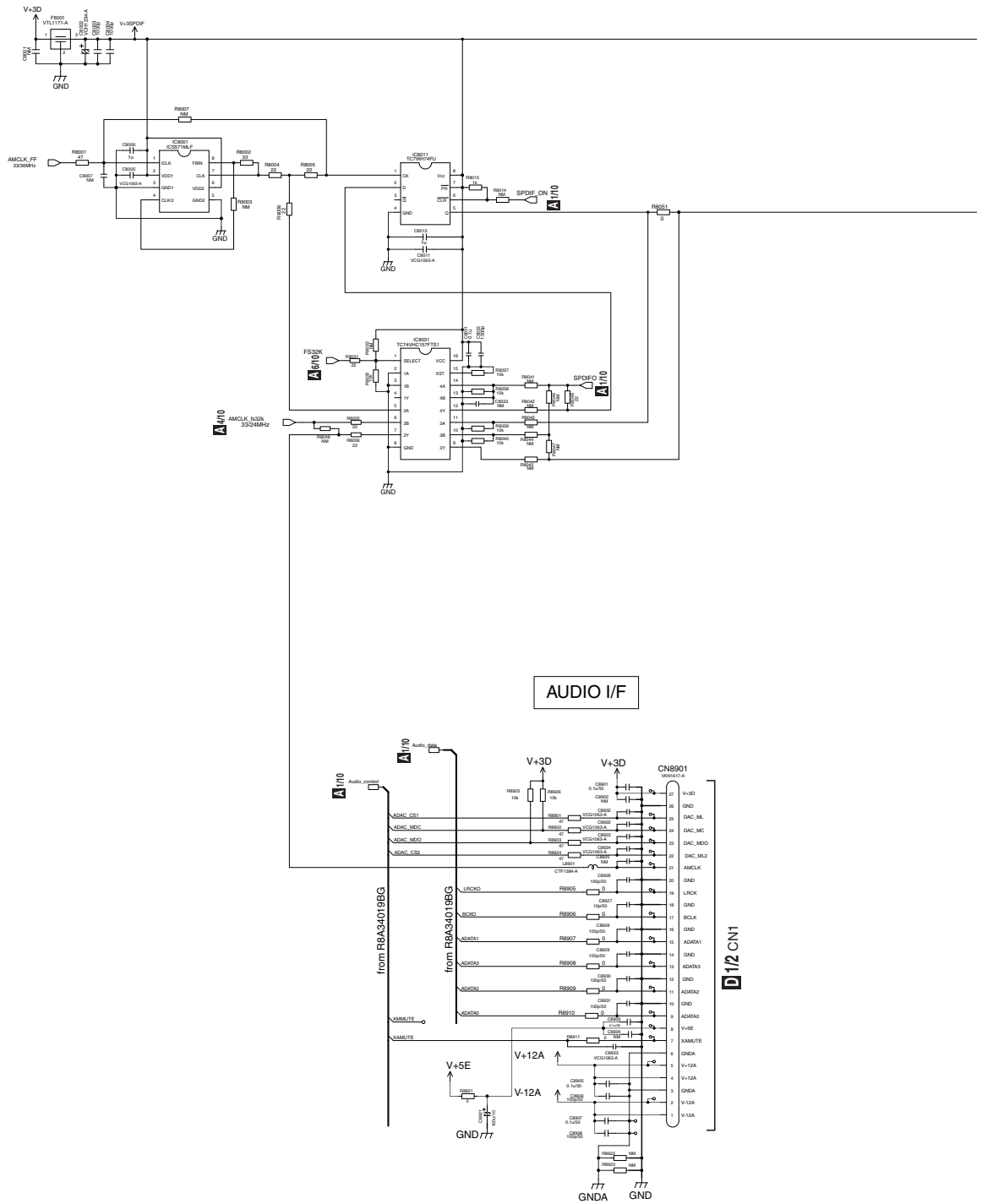

A10/10

A-b 10/10

A
B
C
D
E
F

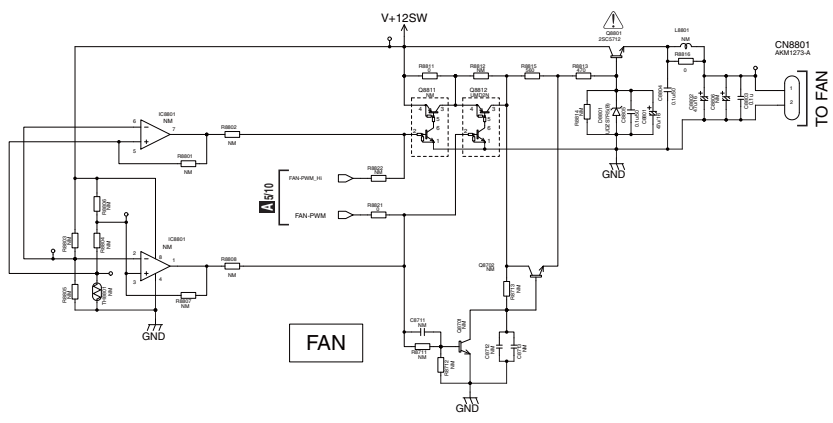
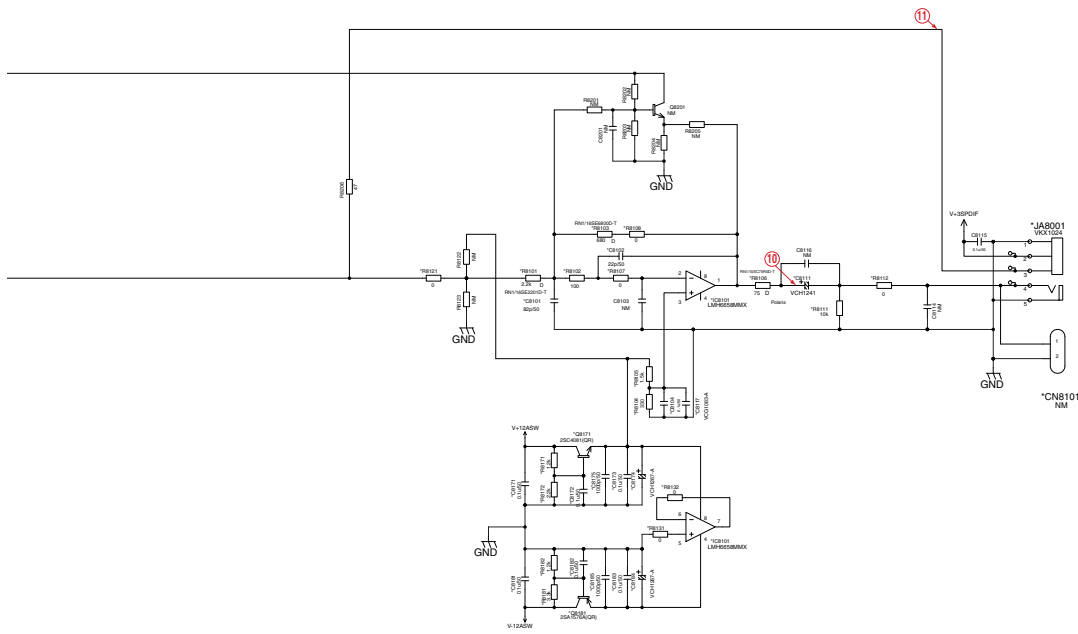

A

B

C

D

E

F

A-a A-b

A-b 10/10

80

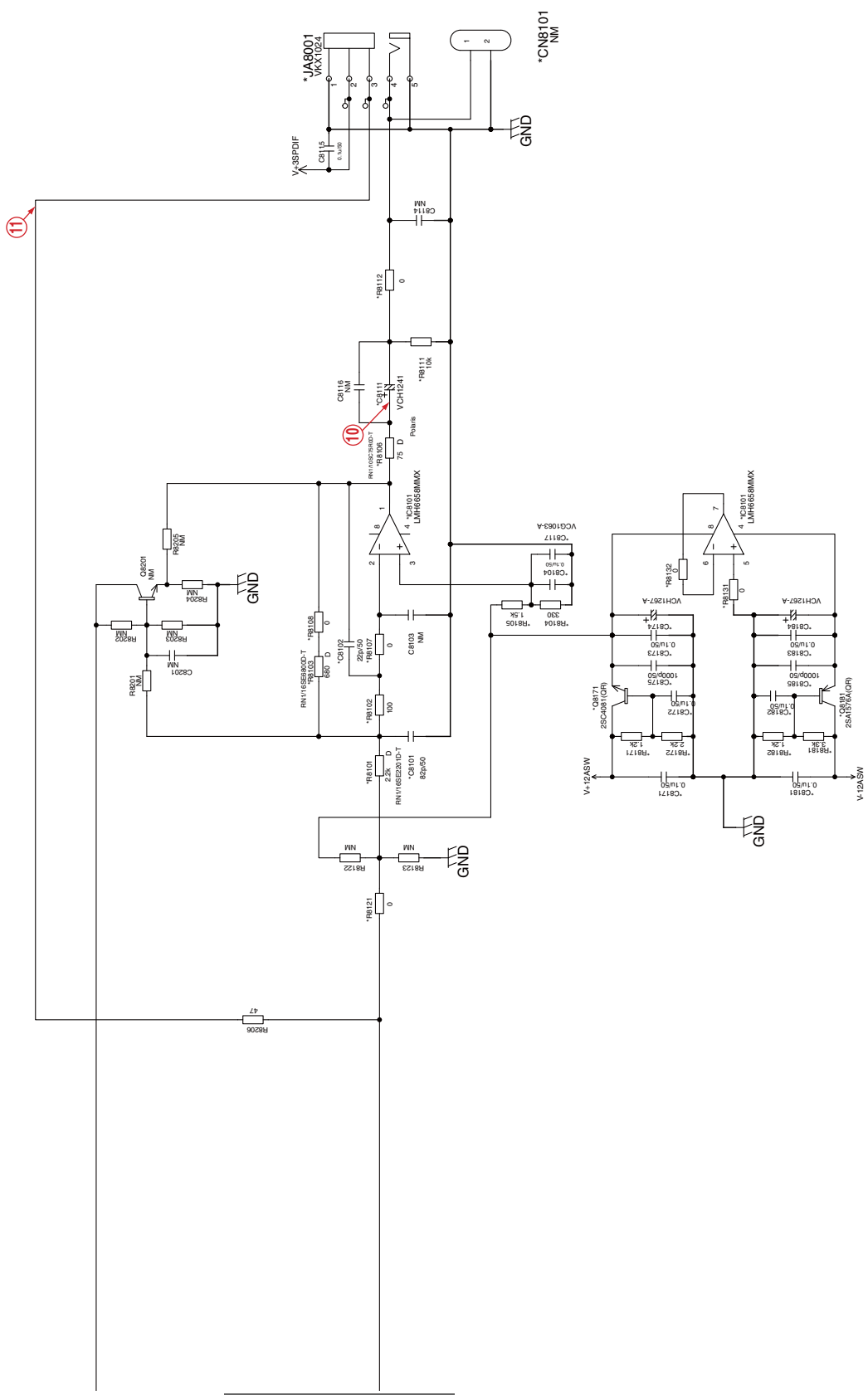

BDP-51FD

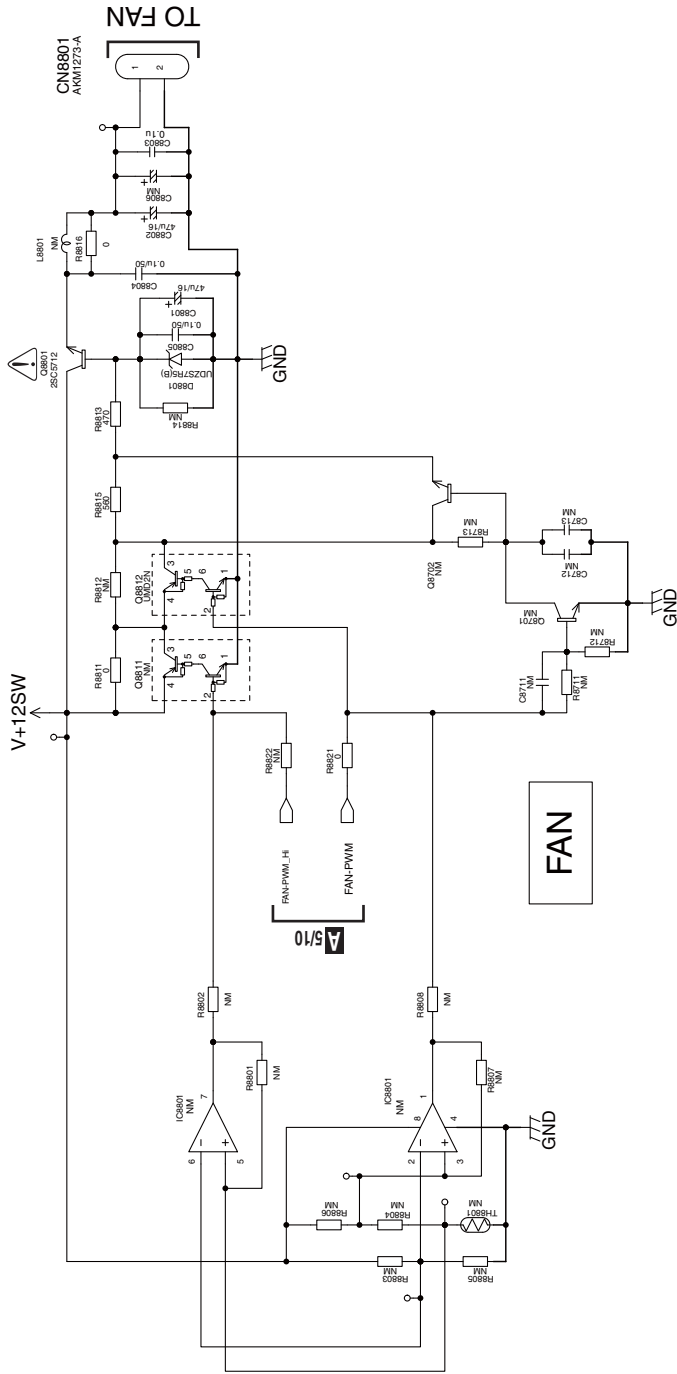

A-a

A10/10 MAIN ASSY (VXX3328)

AUDIO Digital

NOTE

1..SERVICE MAIN ASSY VXX3328
 2..MAIN ASSY (BDP2.0) VWV2375
 2..ATAB ASSY (BDP2.0) VWV2360

NSP

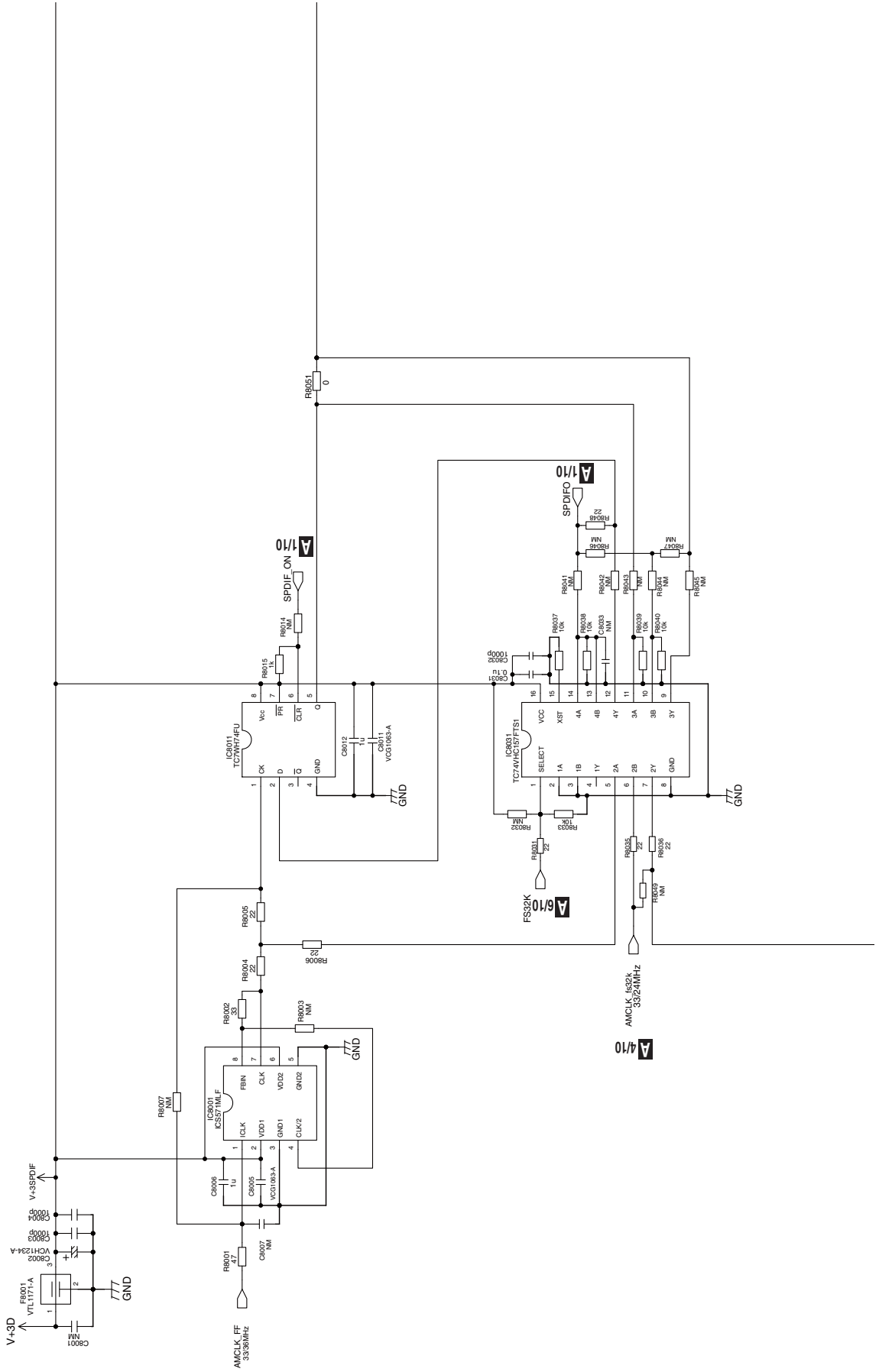

AUDIO I/F

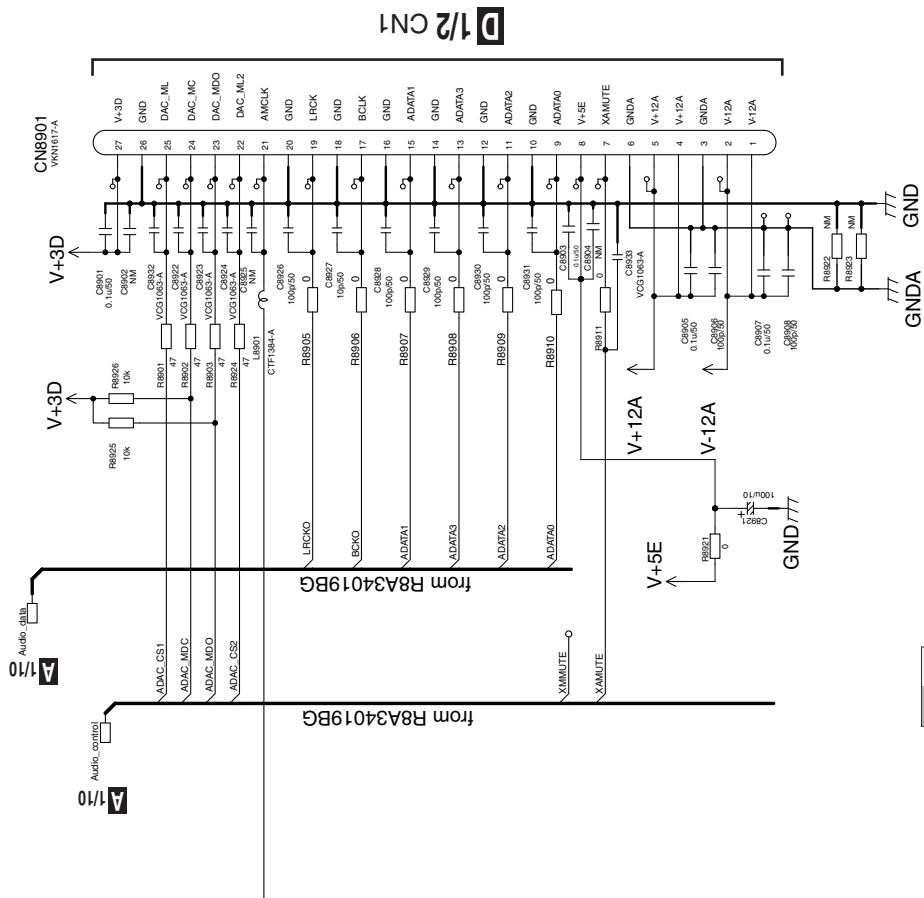

D 1/2 CN1

A-a A-b

10.11 FLKY AND PSWB ASSYS

A
B
C
D
E
F

A510 CN4401

B

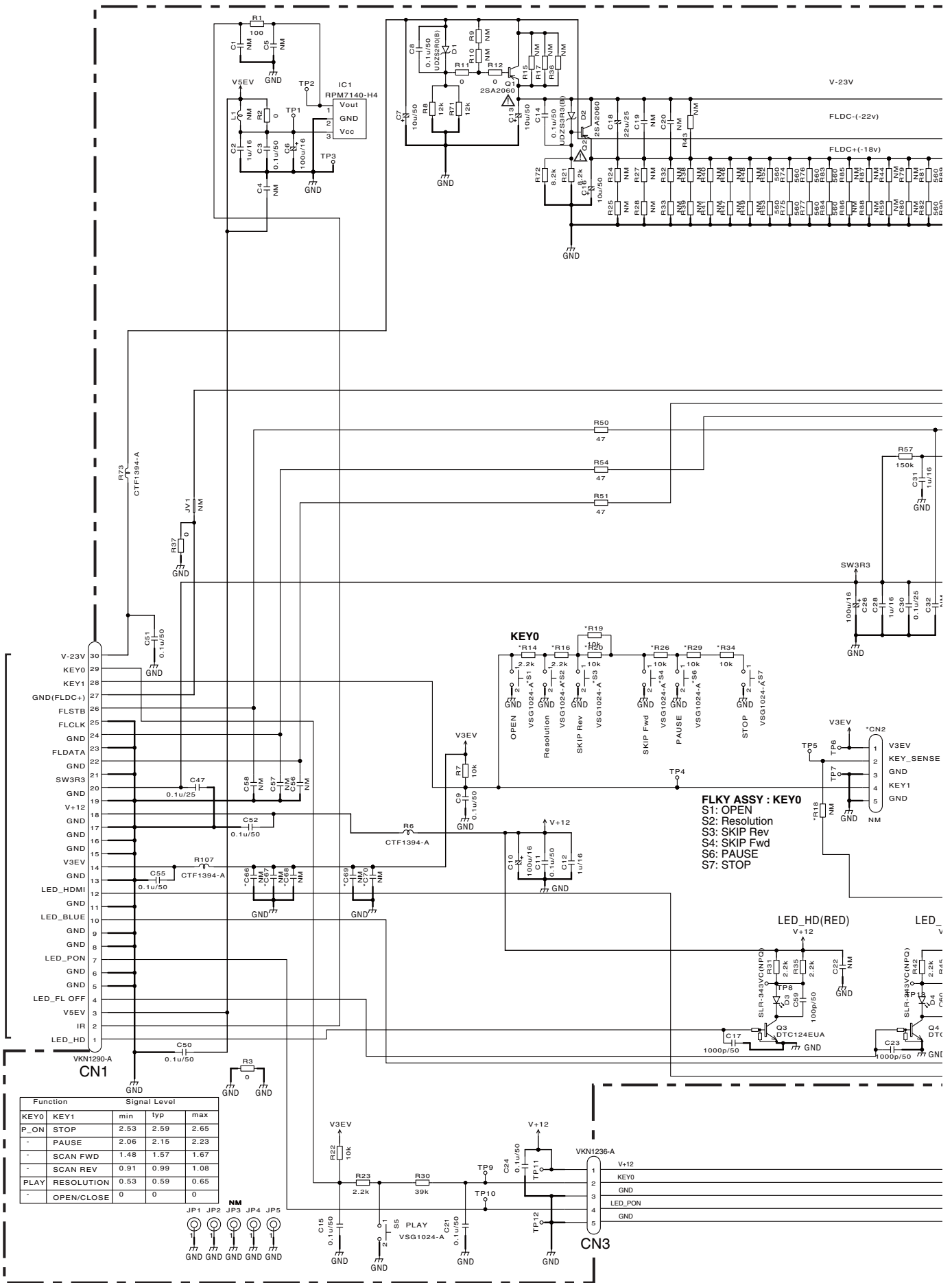

Function	Signal Level		
	KEY0	KEY1	
P_ON	STOP	2.53	2.59
-	PAUSE	2.06	2.15
-	SCAN FWD	1.48	1.57
-	SCAN REV	0.91	0.99
PLAY	RESOLUTION	0.53	0.59
-	OPEN/CLOSE	0	0

FLKY ASSY : KEY0
 S1: OPEN
 S2: Resolution
 S3: SKIP Rev
 S4: SKIP Fwd
 S6: PAUSE
 S7: STOP

BDP-51FD

B FLKY ASSY (VWG2625)

V-23V

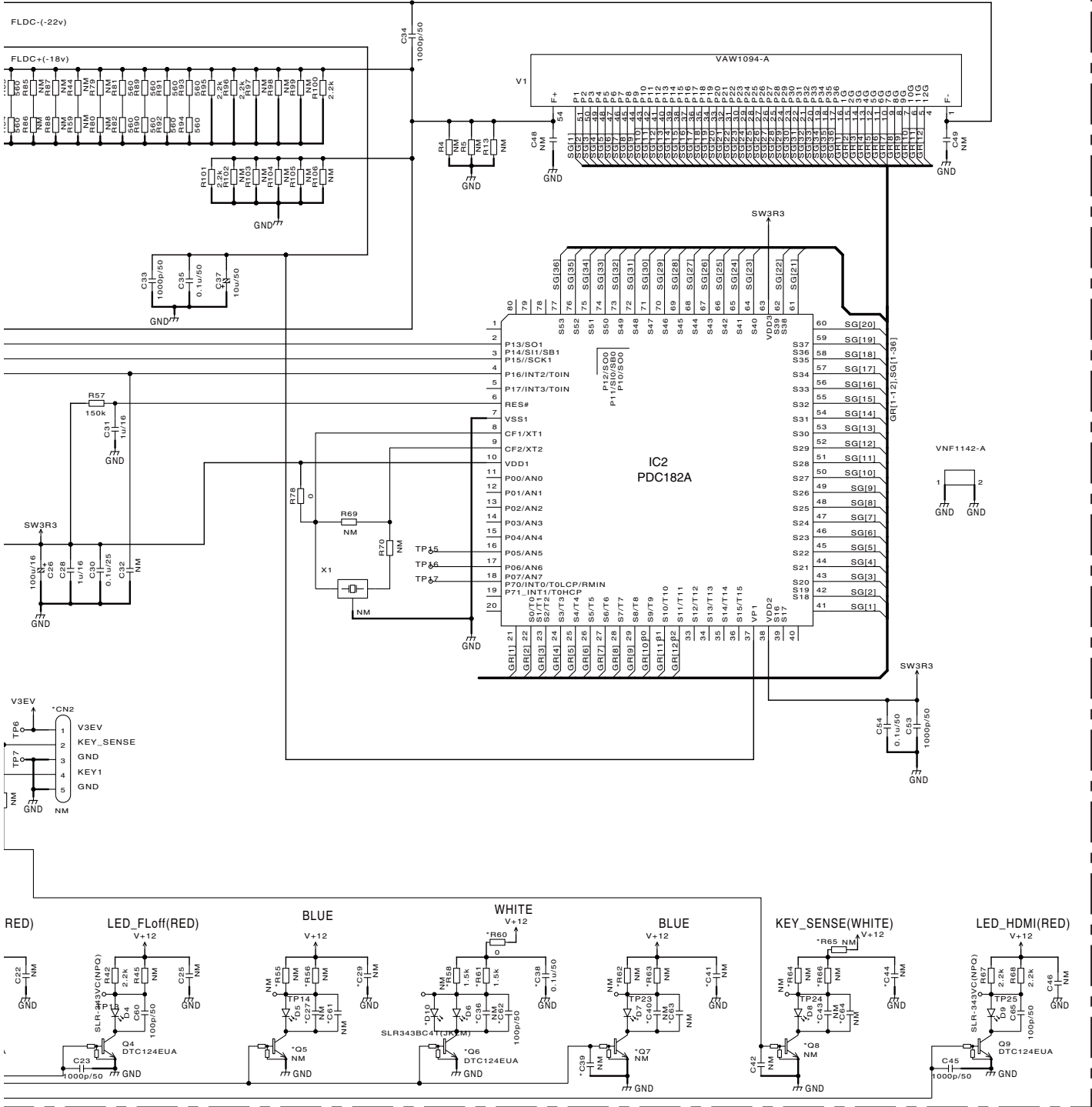

C PSWB ASSY (VWG2613)

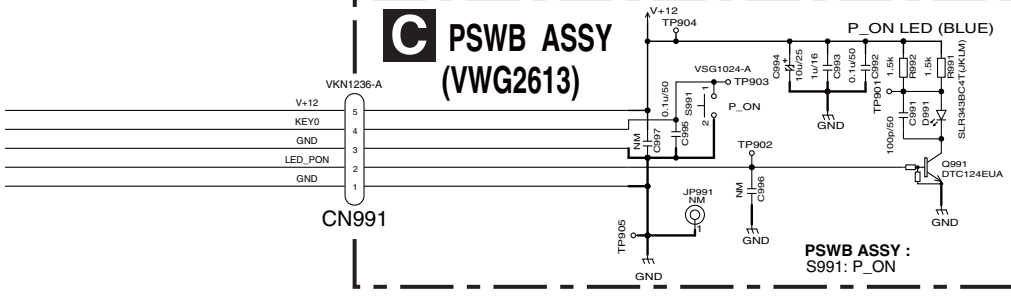

BDP-51FD

B C

10.12 AUJB ASSY (1/2)

1 2 3 4

A

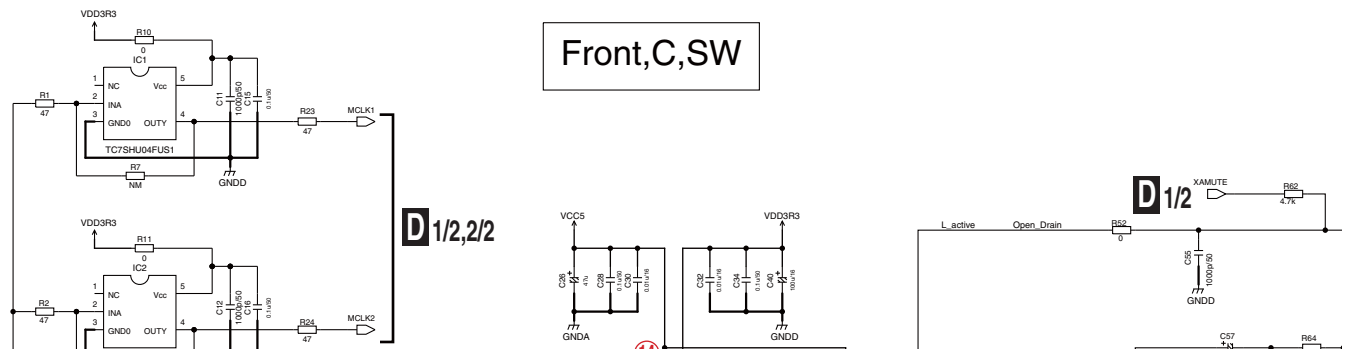

B

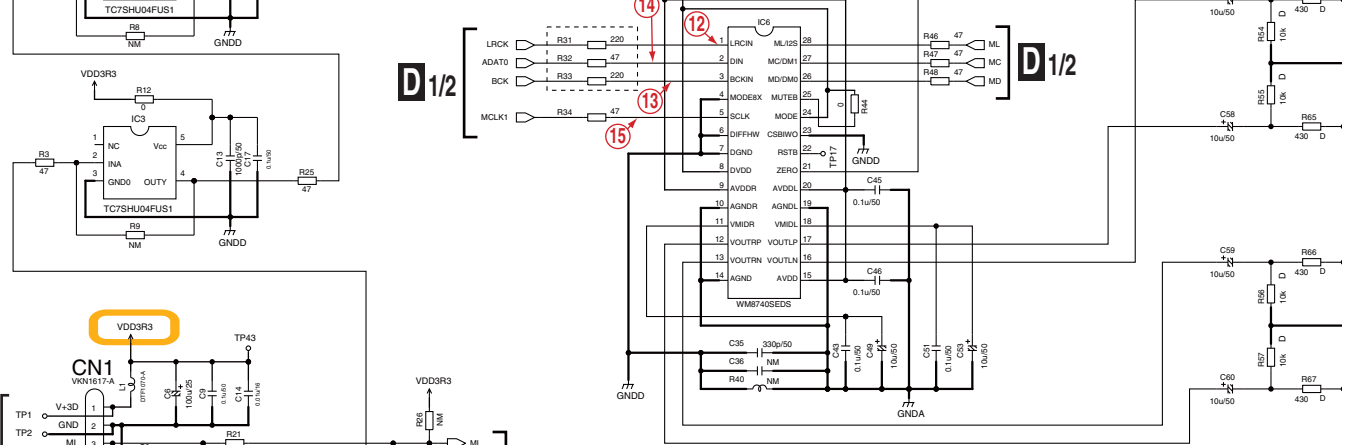

C

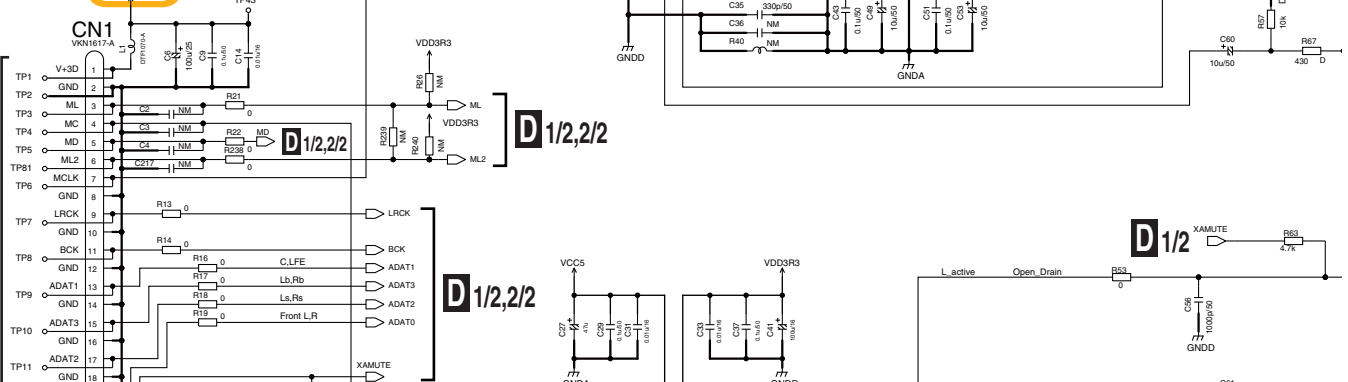

D

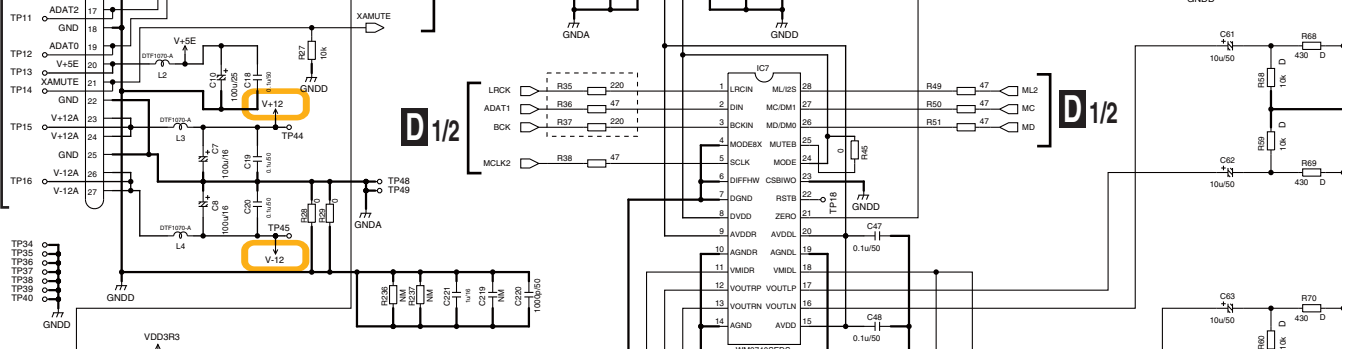

E

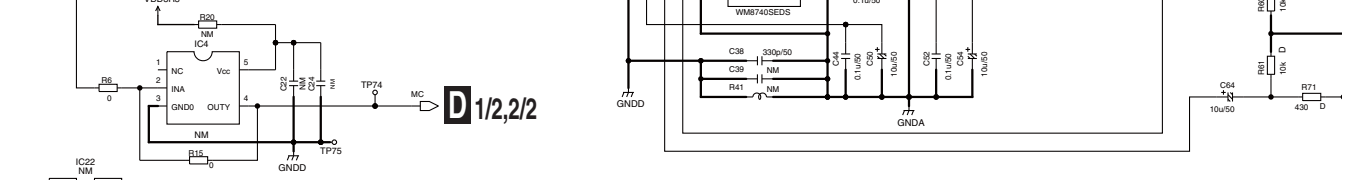

F

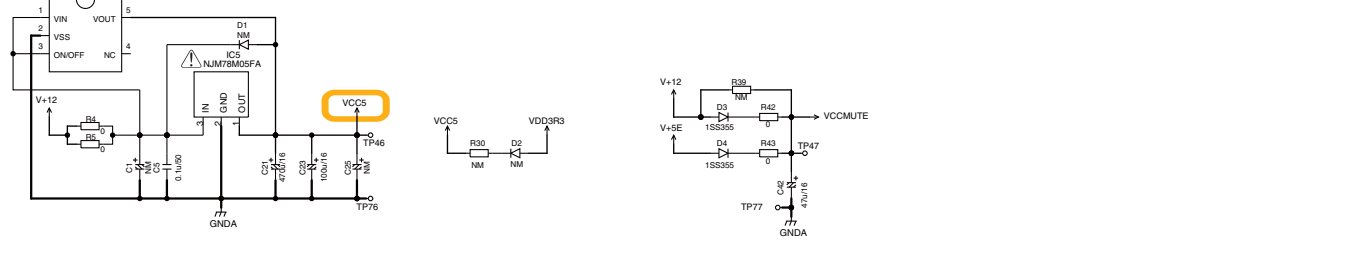

D 1/2

1 2 3 4

D1/2 AUJB ASSY (VWG2632)

VWG2632 : BDP-51FD	
JA1	VKB1159-A
JA2	VKB1159-A
JA3	VKB1130-A
JA4	VKB1265-A

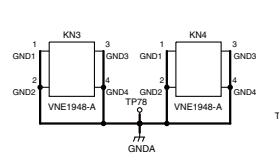
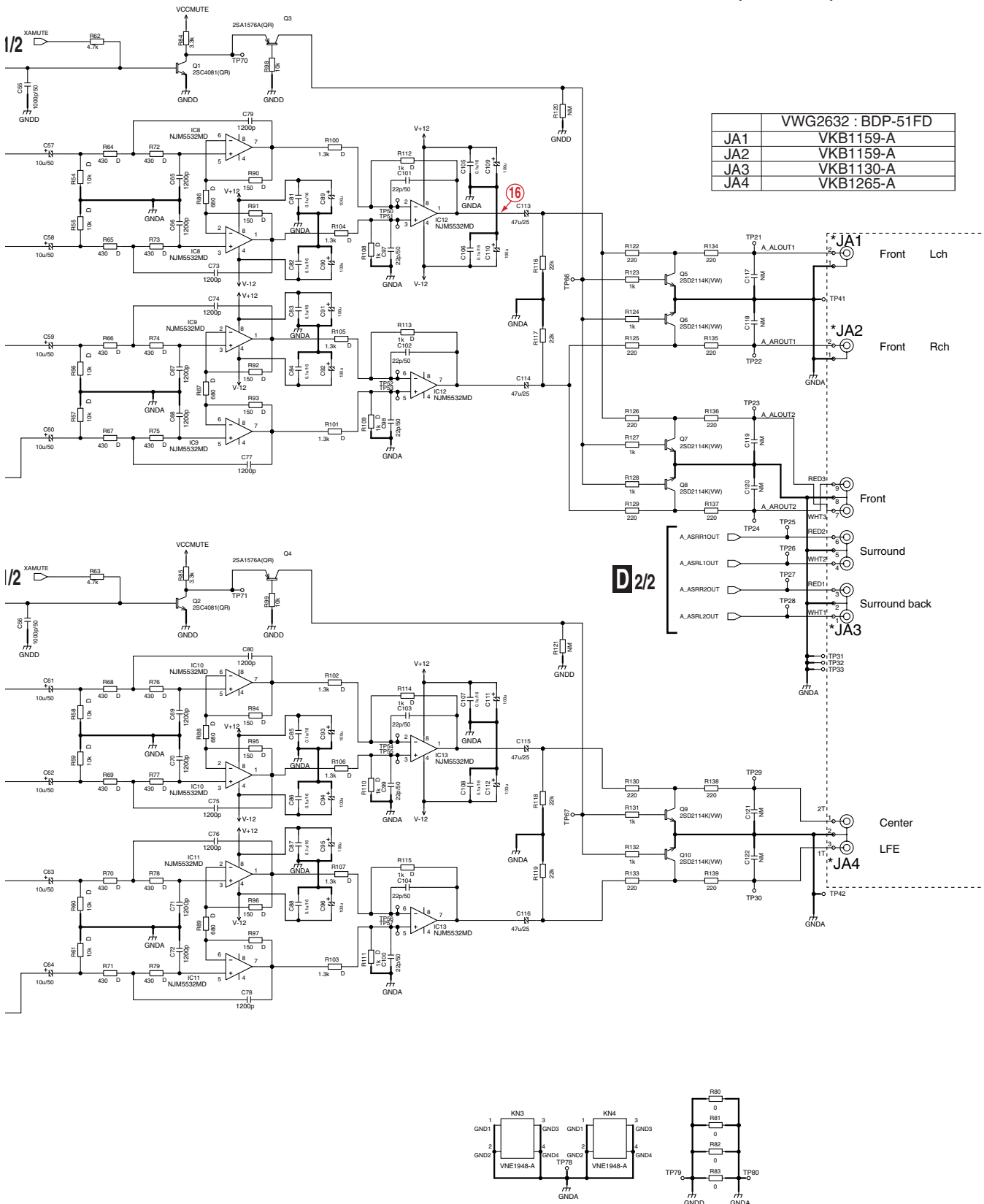

BDP-51FD

10.13 AUJB ASSY (2/2)

1 2 3 4

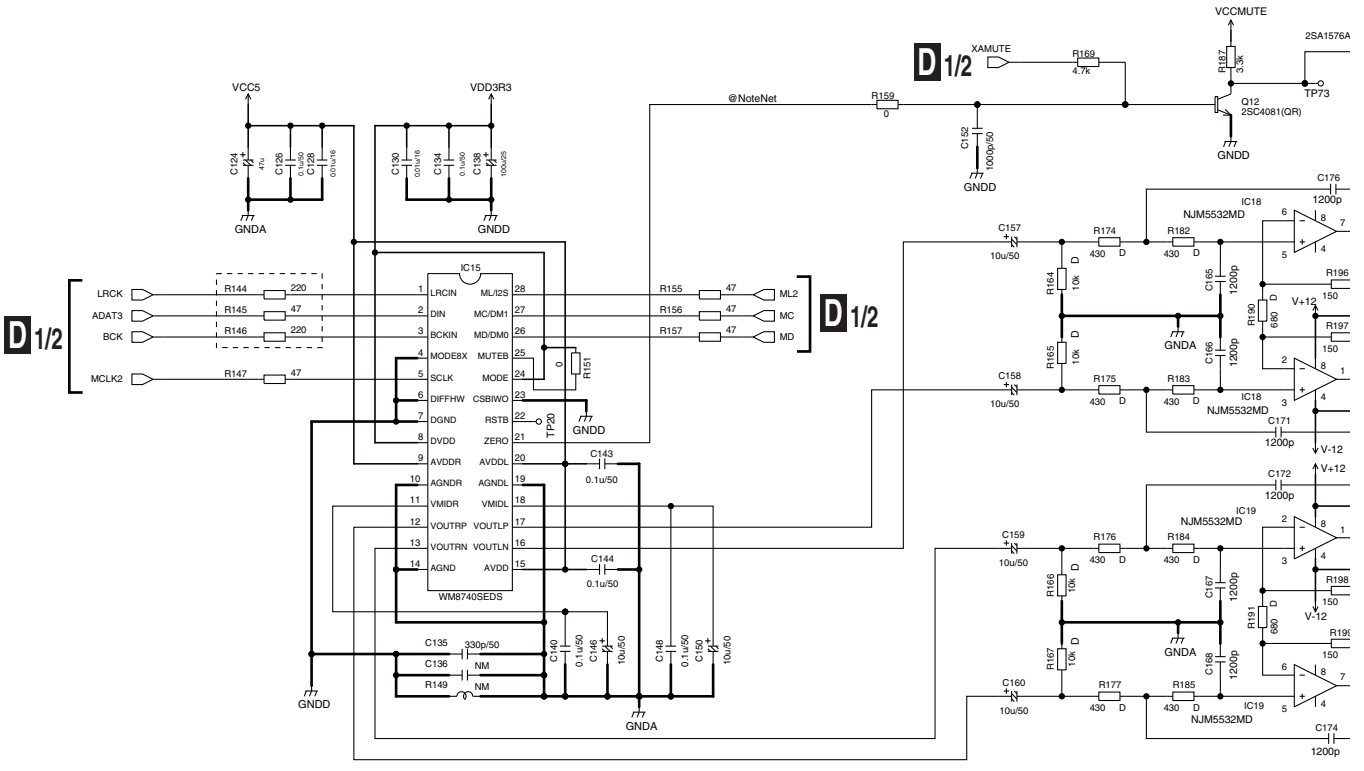
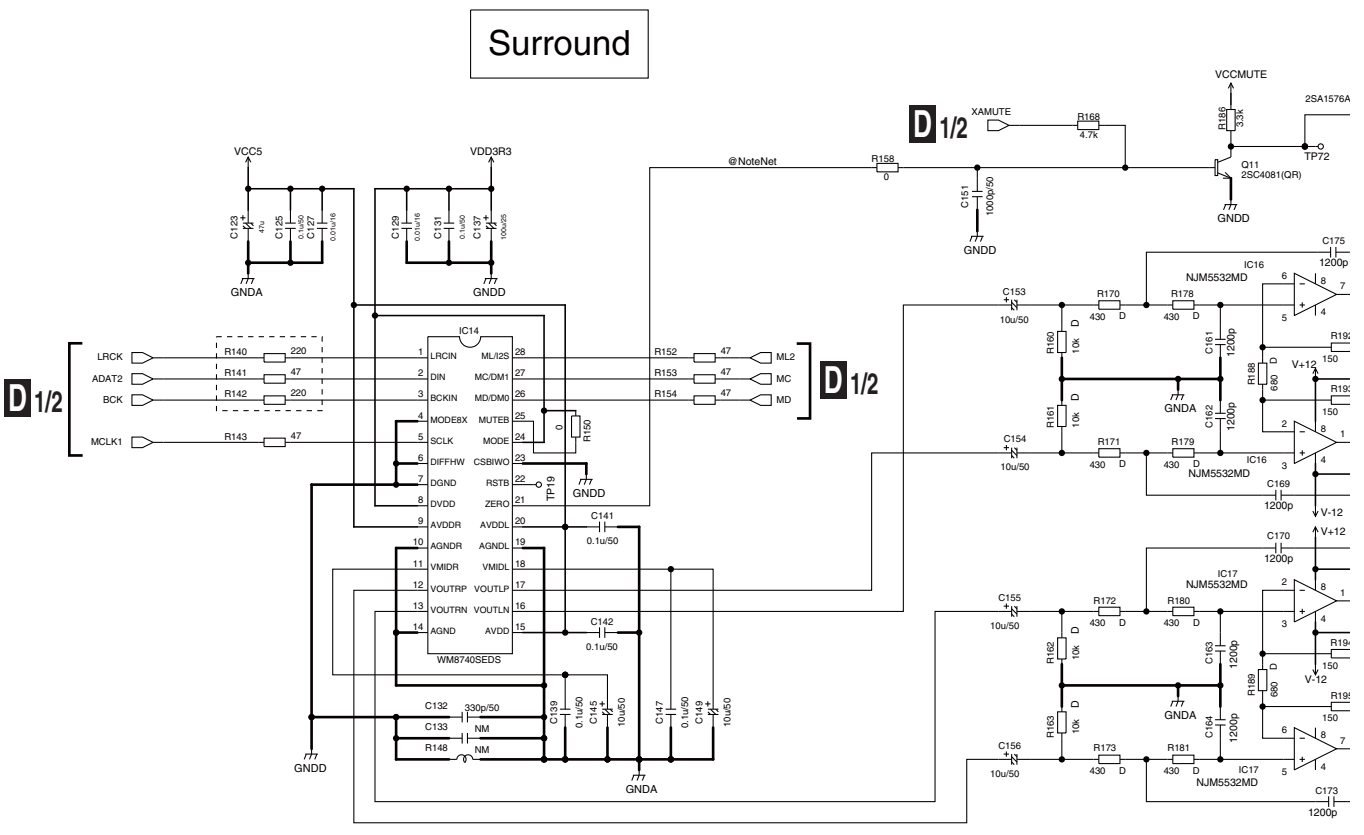

D2/2

1 2 3 4

D2/2 AUJB ASSY (VWG2632)

A
B
C
D
E
F

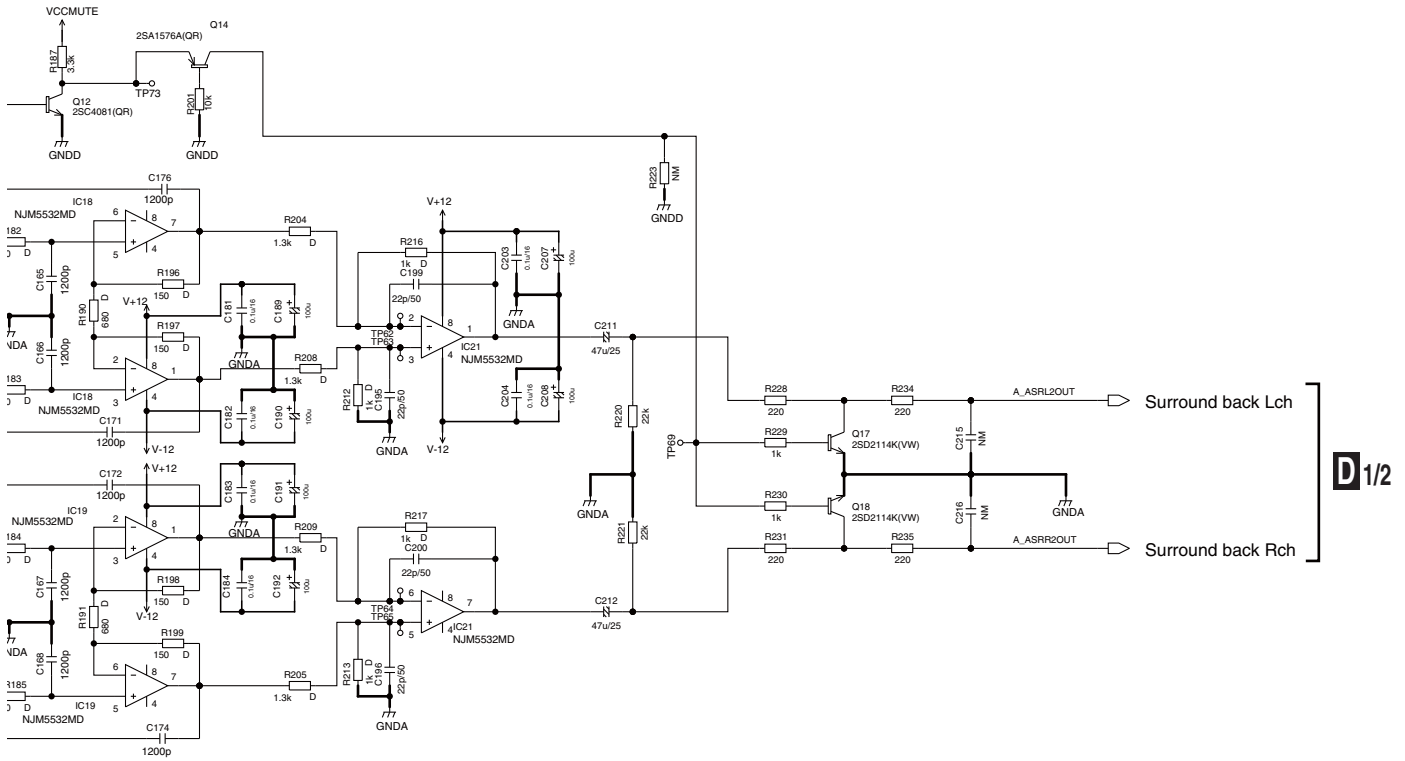
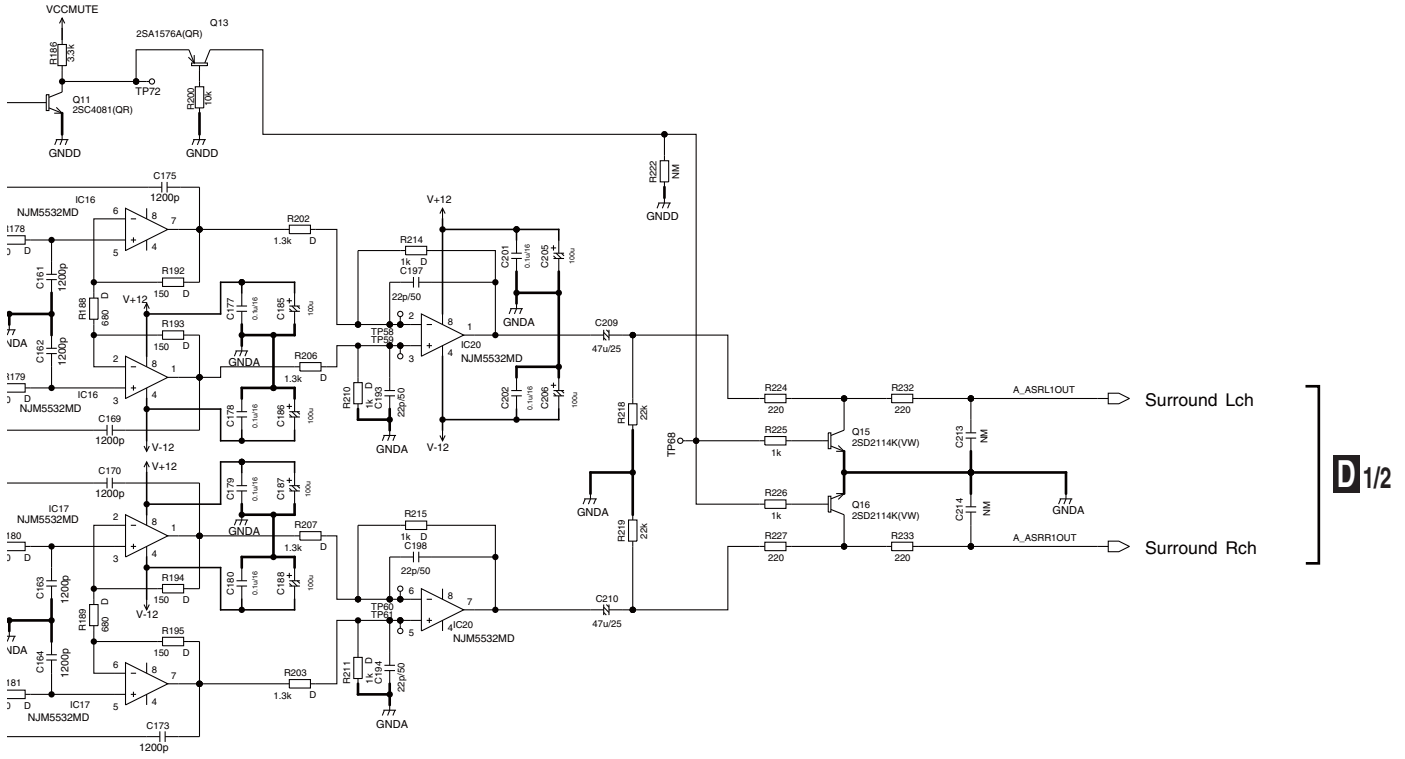

10.14 SYPS ASSY

SYPS ASSY (VWR1415)



TO AC POWER CORD

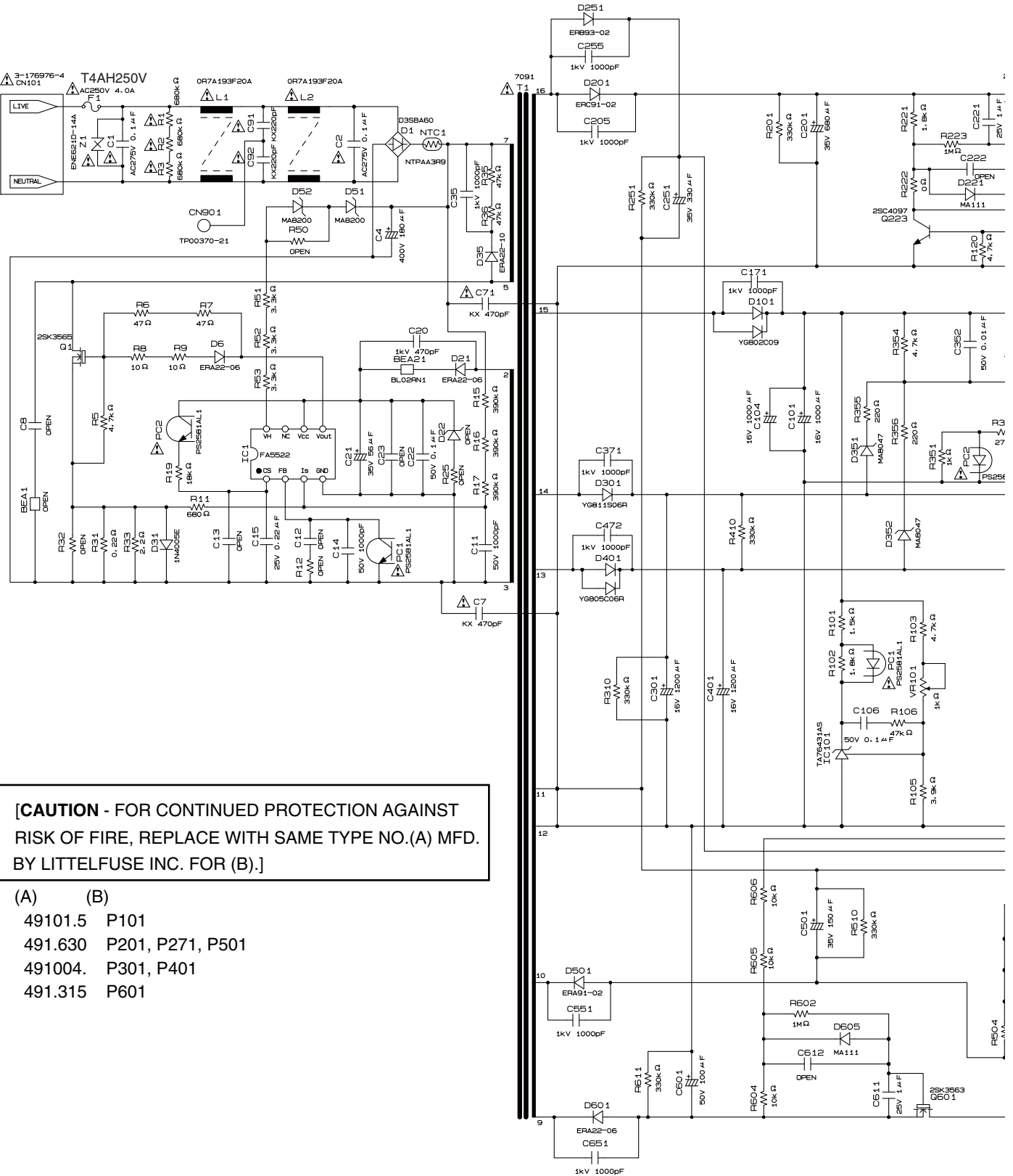

[CAUTION - FOR CONTINUED PROTECTION AGAINST RISK OF FIRE, REPLACE WITH SAME TYPE NO.(A) MFD. BY LITTELFUSE INC. FOR (B).]

- | | |
|---------|------------------|
| (A) | (B) |
| 49101.5 | P101 |
| 491.630 | P201, P271, P501 |
| 491004. | P301, P401 |
| 491.315 | P601 |



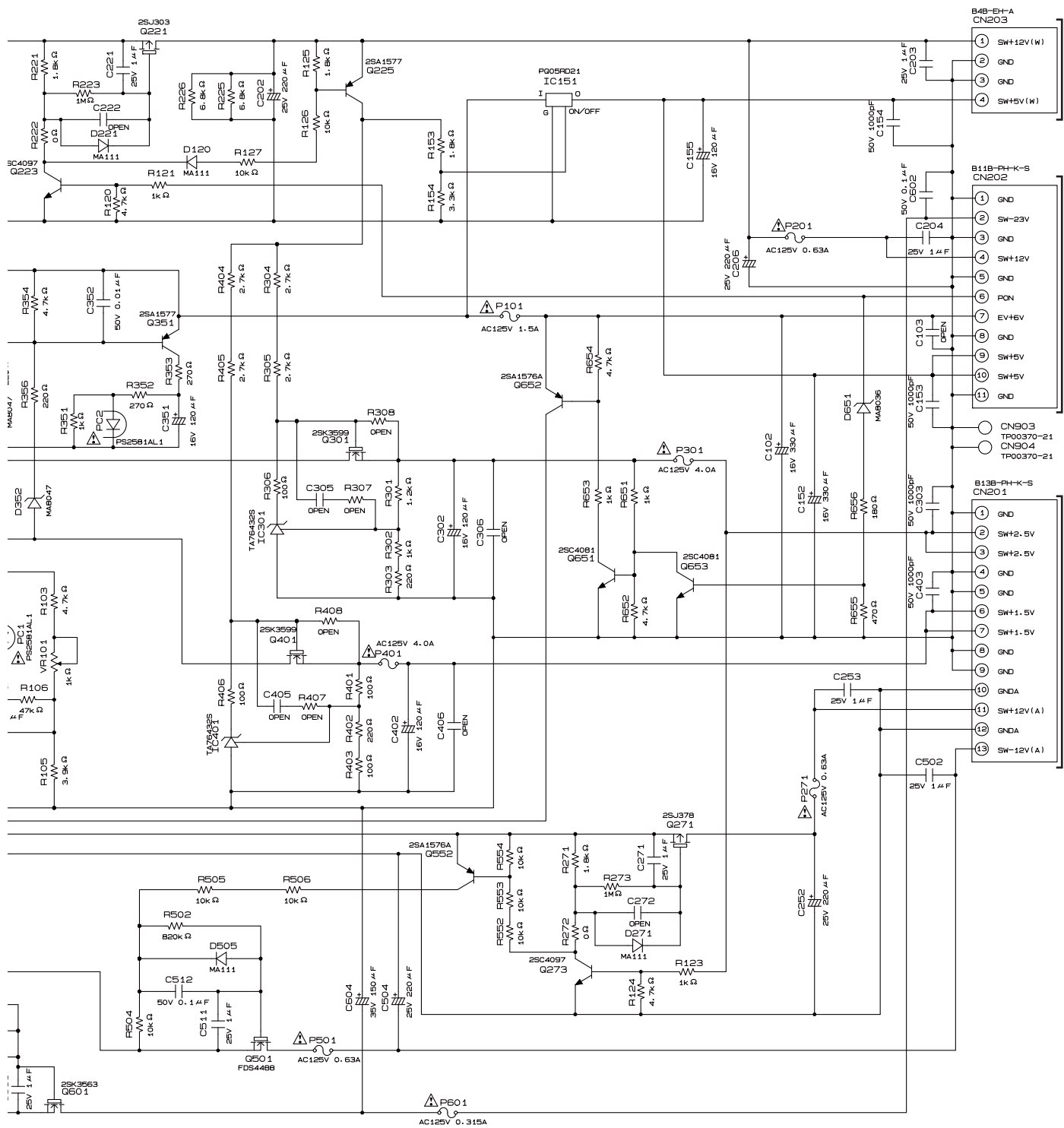

TO DRIVE

A810CN7002

A810CN7001



10.15 WAVEFORMS

Note : The encircled numbers denote measuring point in the schematic diagram.

A MAIN ASSY

① 27 MHz VMCLK
R1141_IC1001
P-ON

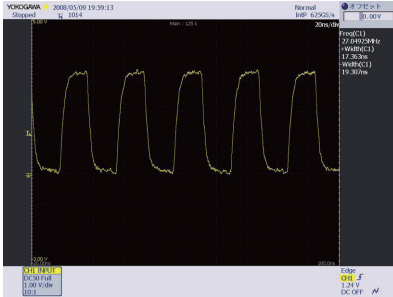

② 36.864 MHz AMCLK1
R1143_IC1001
P-ON



③ 33.8688 MHz AMCLK2
R1142_IC1001
P-ON



④ Video Out
IC6001_27pin
75% Color-bar A1 Disc 2-20

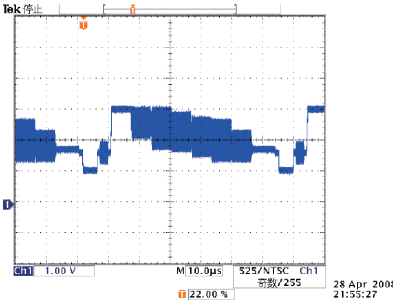

⑤ Y Out
IC6001_25pin
75% Color-bar A1 Disc 2-20

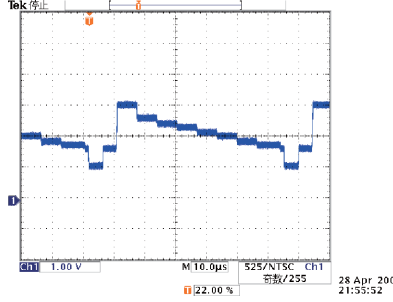

⑥ C Out
IC6001_29pin
75% Color-bar A1 Disc 2-20

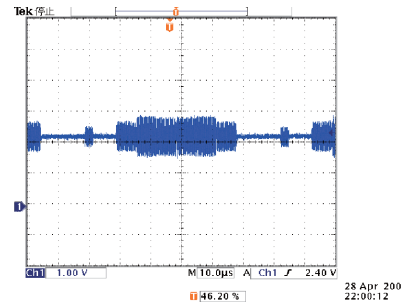

⑦ Component Y Out
IC6001_23pin
75% Color-bar A1 Disc 2-20

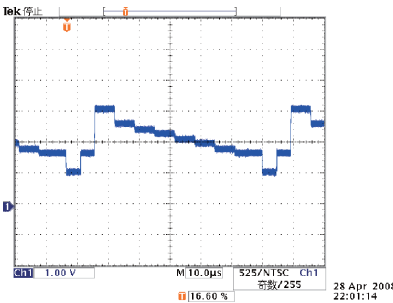

⑧ Cb Out
IC6001_21pin
75% Color-bar A1 Disc 2-20

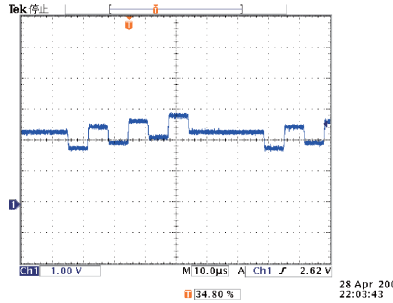

⑨ Cr Out
IC6001_18 pin
75% Color-bar A1 Disc 2-20

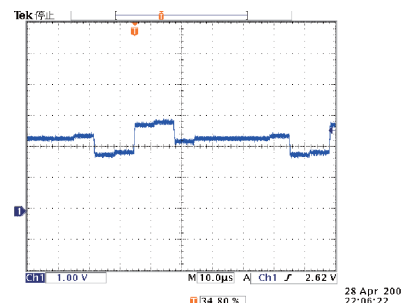

⑩ CoAxial Out
C8111_+ side
1kHz 2Vrms A1 Disc 2-1

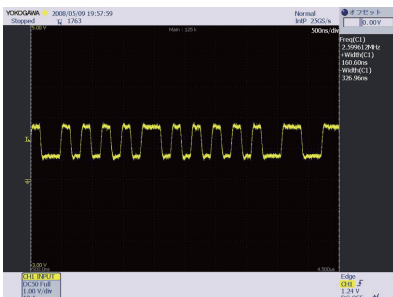

⑪ Optical Out
R8206_JA8001 side
1kHz 2Vrms A1 Disc 2-1



D AUJB ASSY

12 LRCK
IC6_1pin
1kHz 2Vrms

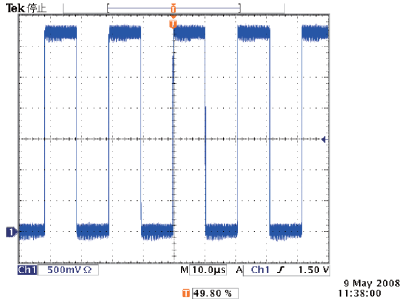

13 BCK
IC6_3pin
1kHz 2Vrms

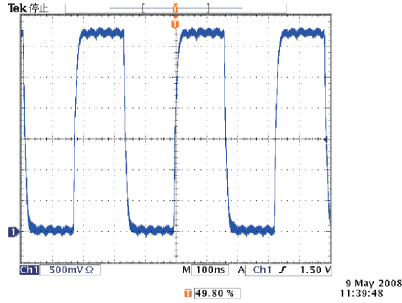

14 ADATA0
IC6_2pin
1kHz 2Vrms

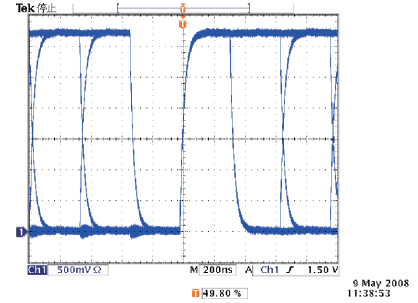

15 MCLK
IC6_5pin
1kHz 2Vrms

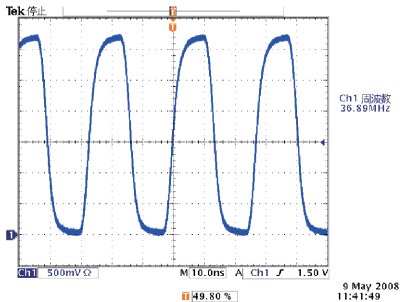

16 LOUT
IC12_1pin
1kHz 2Vrms

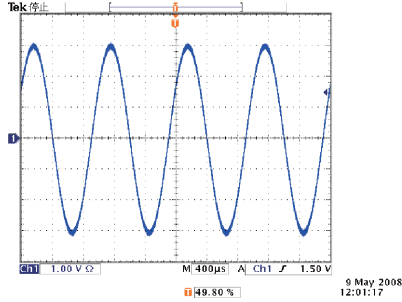

SIDE B

A

B

C

D

E

F

IC	Q
	Q5231
IC8011	Q5202
Q5232	
IC5321	Q6404
IC7501	Q6405
IC5811	Q5311
Q8201	
Q5035	
IC2151	Q6002
IC5812	
IC5803	
IC2601	
IC5802	
IC2101	
IC2199	
IC2661	
IC5401	
IC7421	
Q6501	
Q6502	
Q6503	
Q6504	
IC2401	
IC2499	
Q6505	
IC3861	
IC1621	
IC7201	
IC3361	
IC3301	Q4001
IC3551	Q4002
IC7301	
IC8801	Q4003
Q8702	
Q8801	
Q8811	
Q4004	
IC4001	Q8812

A MAIN ASSY

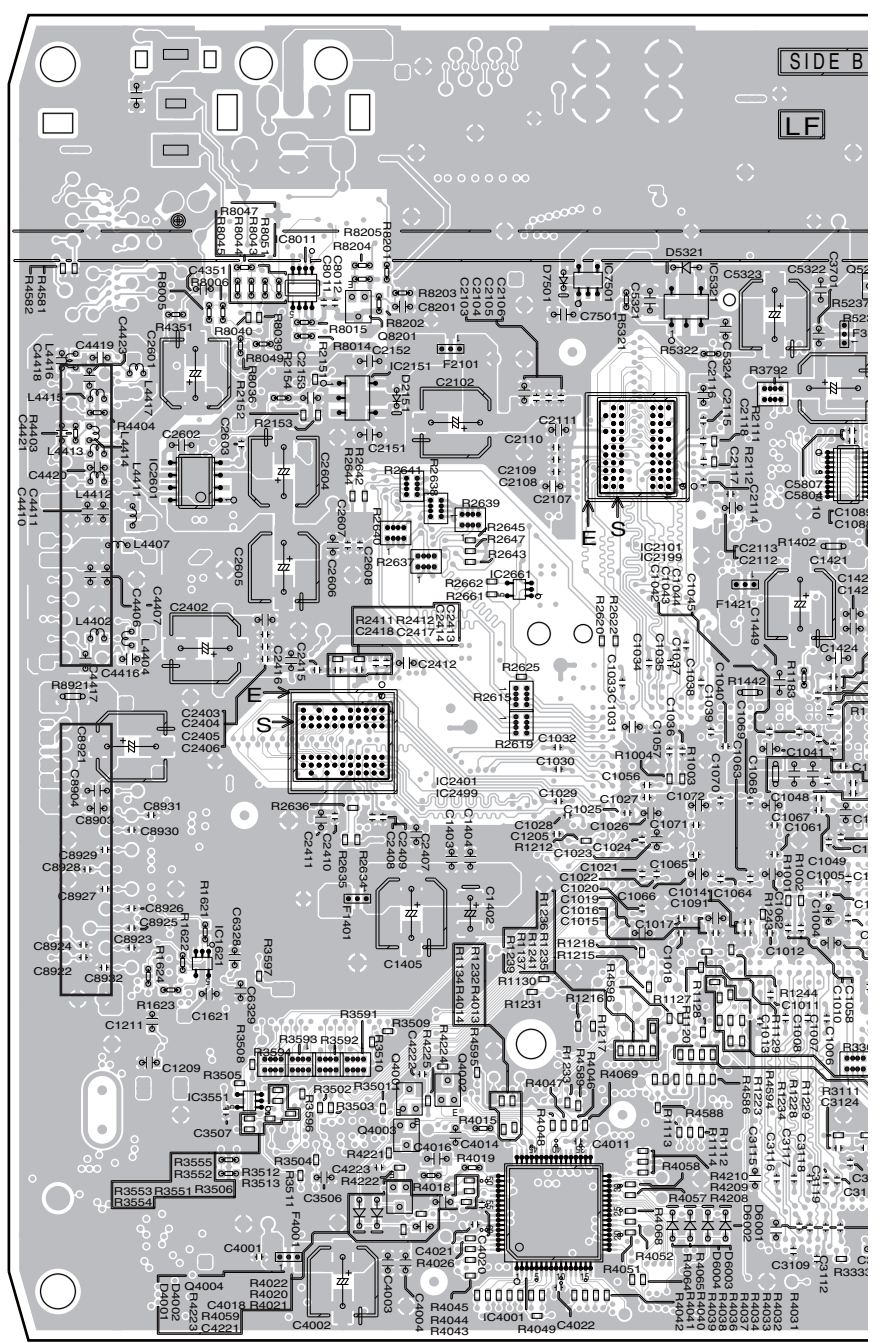

SIDE B

A

B

C

D

E

F

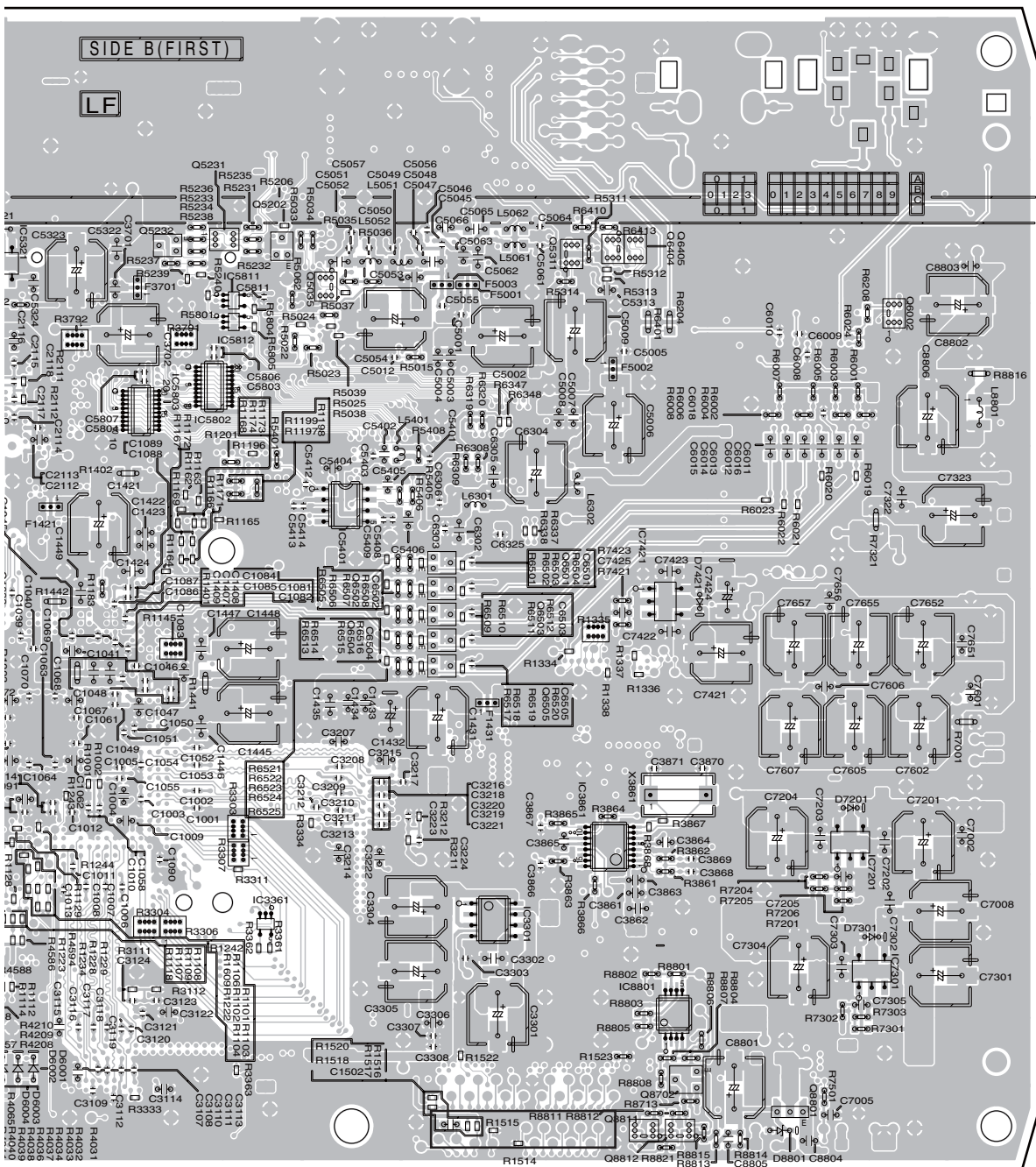

SIDE B (FIRST)

LF

CN1501

(VNP2080-C)

ATAB ASSY

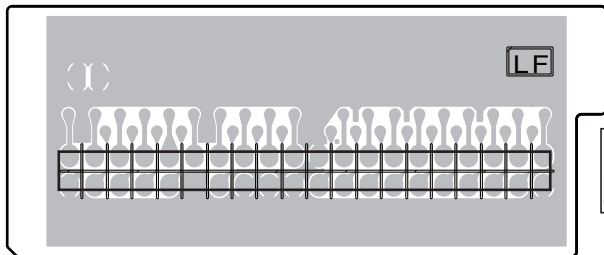

(VNP2080-C)

BDP-51FD

A

11.2 FLKY AND PSWB ASSYS

SIDE A

B FLKY ASSY

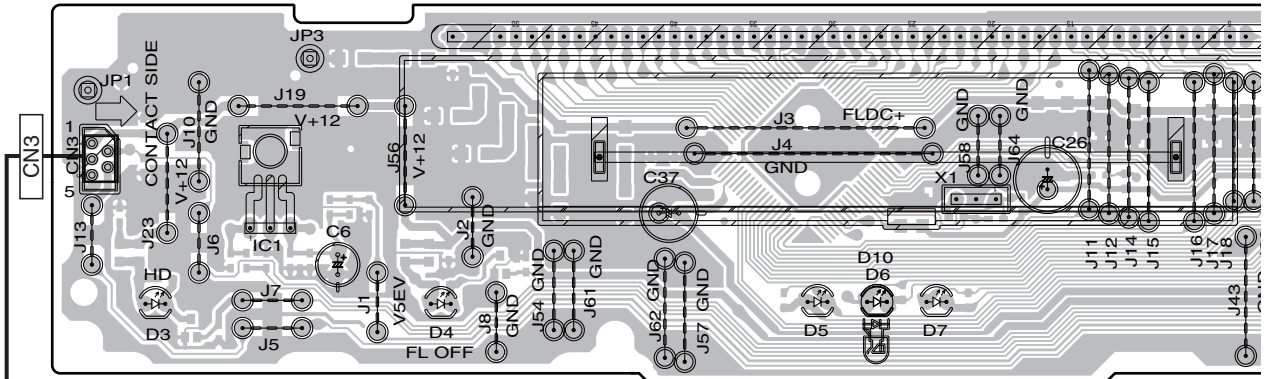

C PSWB ASSY

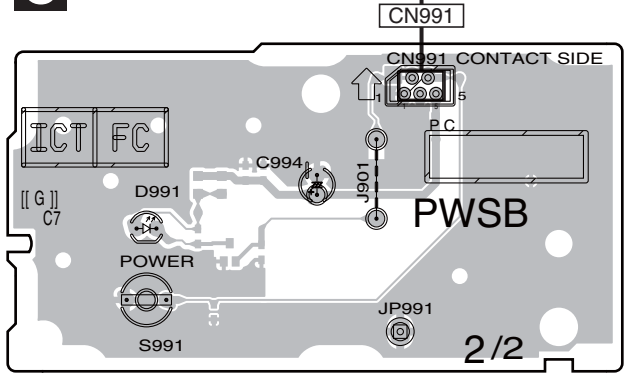

(VNP2106-B)

B C

SIDE A

A

B

C

D

E

F

B

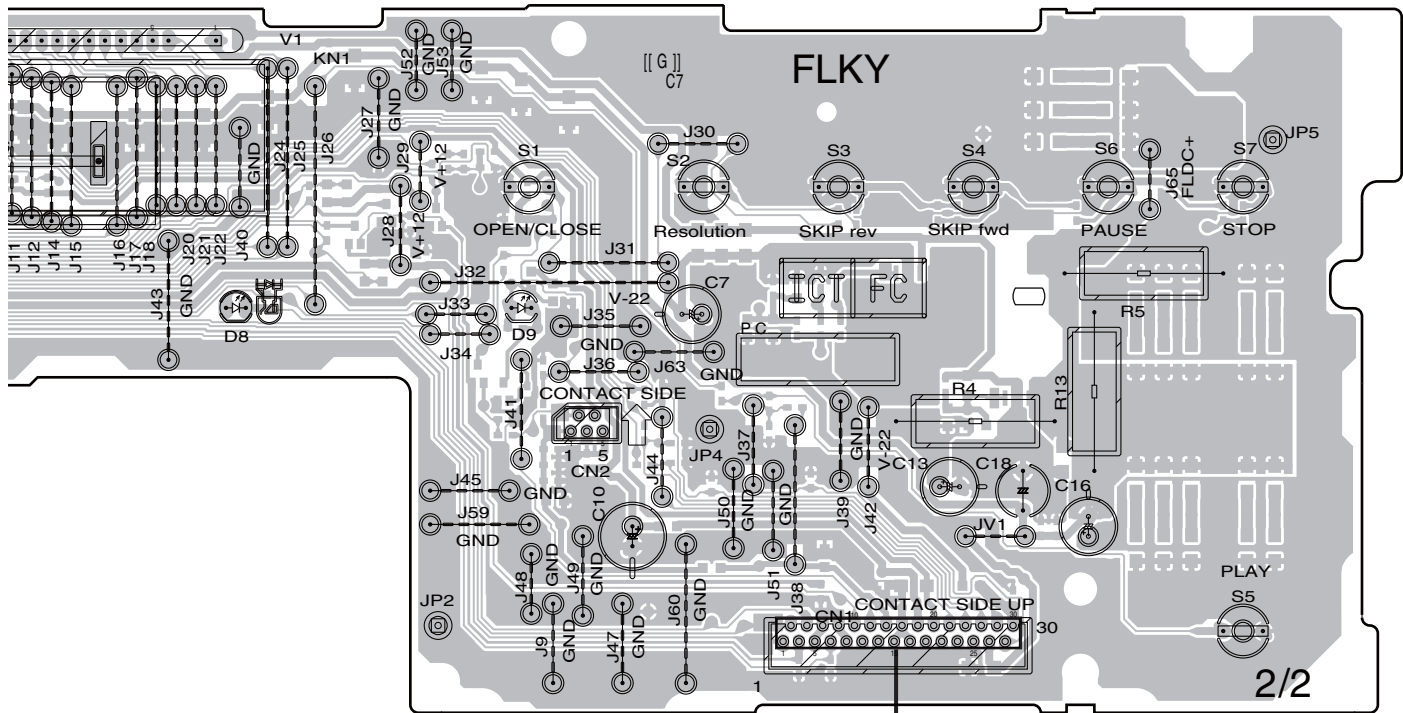

CN1

A CN4401

2/2

(VNP2106-B)

SIDE B

B FLKY ASSY

IC Q

IC2

Q6 Q7
Q5 Q4
Q1 Q3
Q9 Q8
Q2

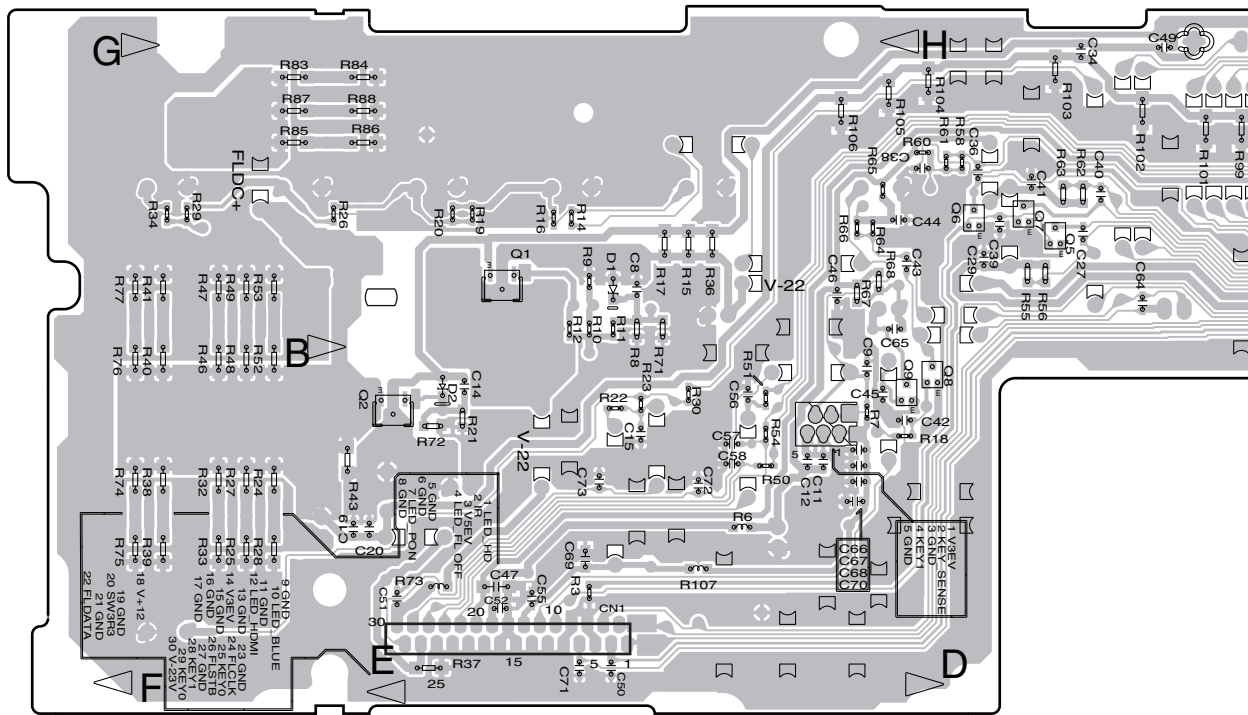

CN1

B

100

BDP-51FD

SIDE B

A

B

C

D

E

F

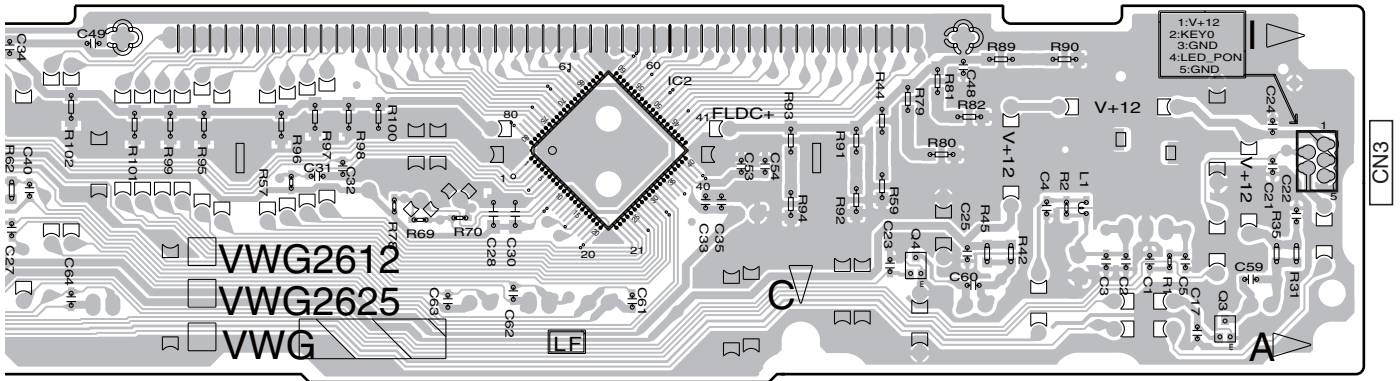

(VNP2106-B)

C PSWB ASSY

IC

Q

Q991

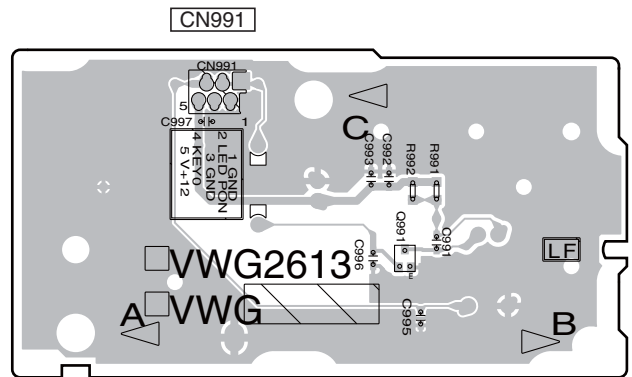

(VNP2106-B)

C B

SIDE B

SIDE B

A

B

C

D

E

F

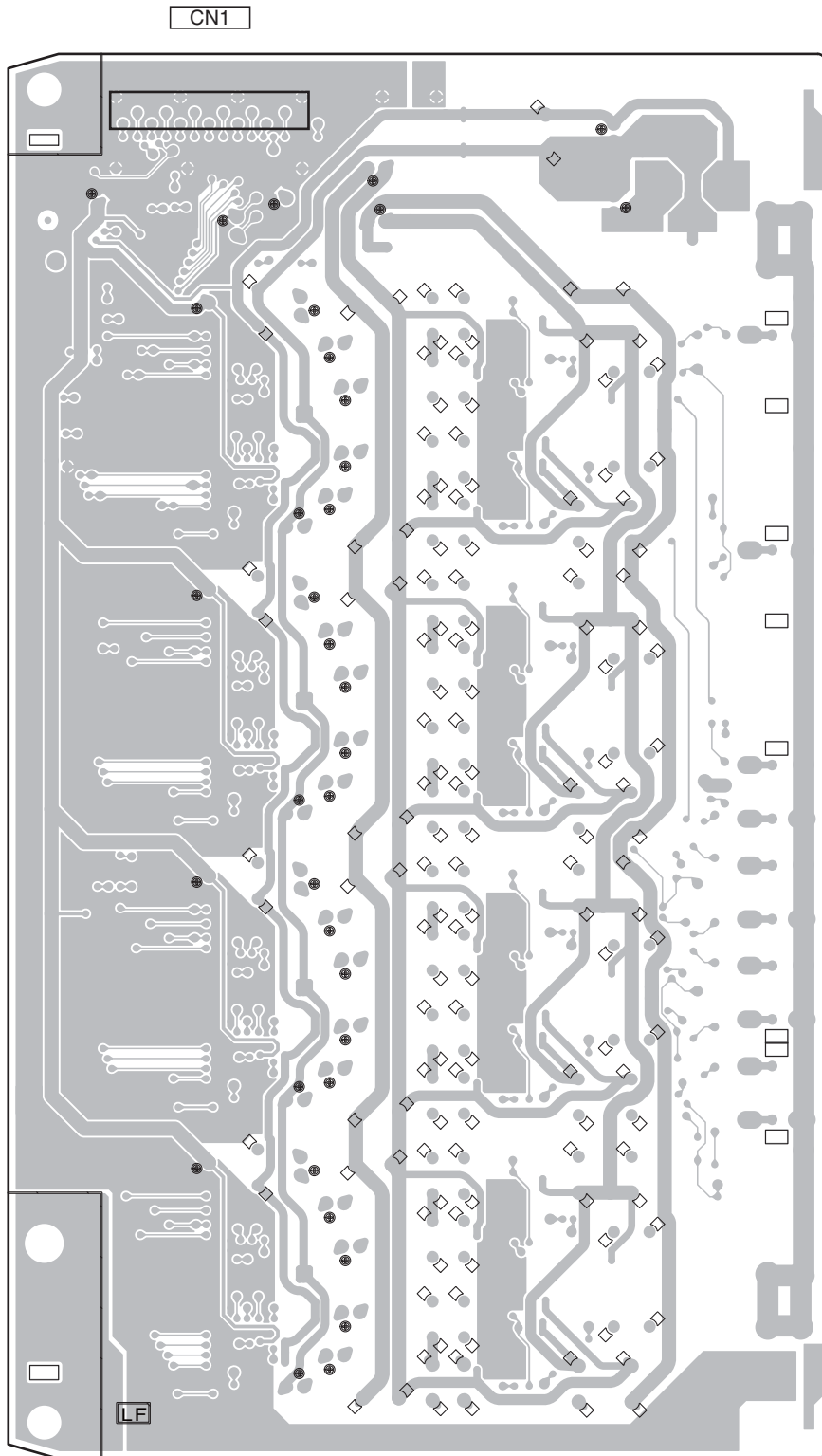

(VNP2107-A)

BDP-51FD

D

SIDE B

SIDE B

G SYPS ASSY

A

B

C

D

E

F

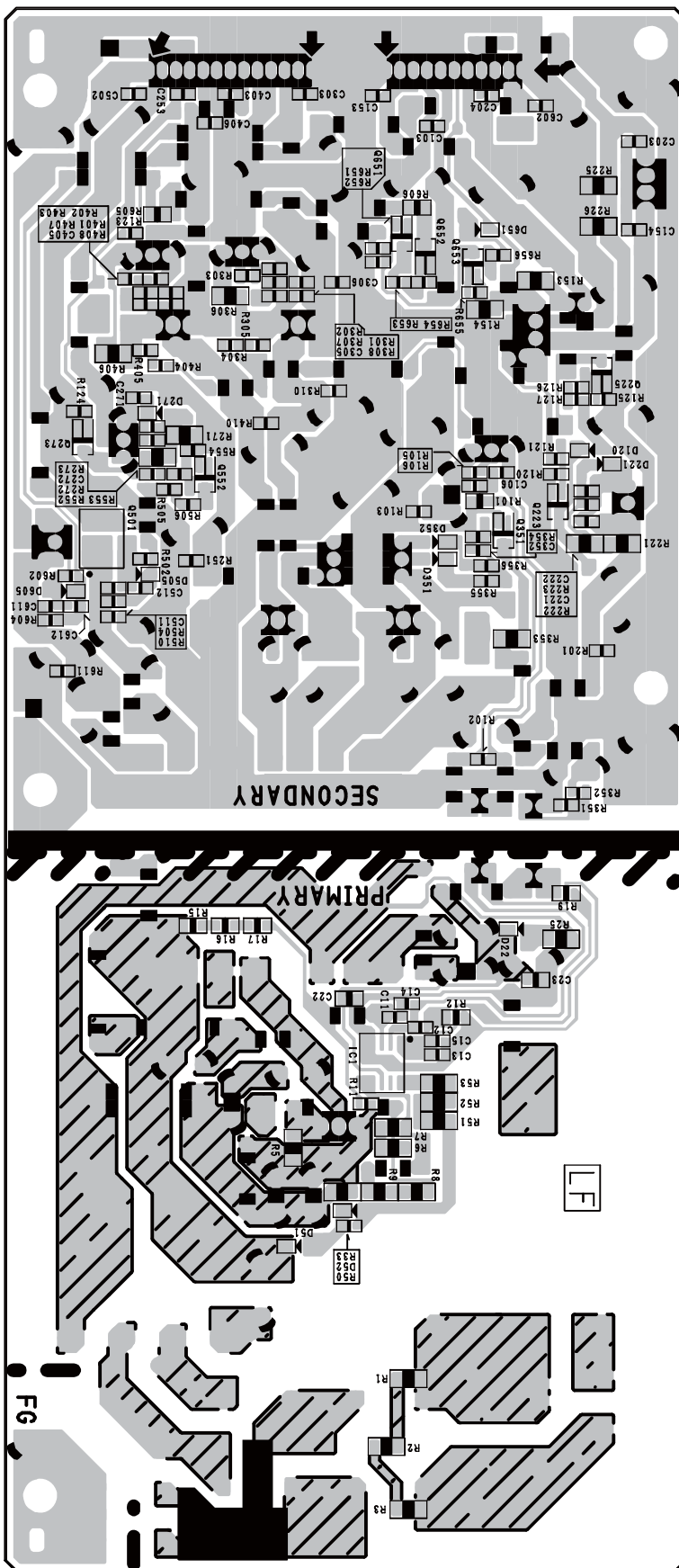

SECONDARY

PRIMARY

FG

G

G

BDP-51FD

12. PCB PARTS LIST

NOTES: ● Parts marked by "NSP" are generally unavailable because they are not in our Master Spare Parts List.

● The Δ mark found on some component parts indicates the importance of the safety factor of the part. Therefore, when replacing, be sure to use parts of identical designation.

● When ordering resistors, first convert resistance values into code form as shown in the following examples.

Ex.1 When there are 2 effective digits (any digit apart from 0), such as 560 ohm and 47 k ohm (tolerance is shown by J = 5%, and K = 10%).

560 Ω \rightarrow 56 $\times 10^1$ \rightarrow 561 RD1/APU $\boxed{5}$ $\boxed{6}$ $\boxed{7}$ J

47 k Ω \rightarrow 47 $\times 10^3$ \rightarrow 473 RD1/APU $\boxed{4}$ $\boxed{7}$ $\boxed{3}$ J

0.5 Ω \rightarrow R50 RN2H \boxed{R} $\boxed{5}$ $\boxed{0}$ K

1 Ω \rightarrow 1R0 RSIP $\boxed{1}$ \boxed{R} $\boxed{0}$ K

Ex.2 When there are 3 effective digits (such as in high precision metal film resistors).

5.62 k Ω \rightarrow 562 $\times 10^1$ \rightarrow 5621 RN1/4PC $\boxed{5}$ $\boxed{6}$ $\boxed{2}$ $\boxed{1}$ F

● Meaning of the figures and others in the parentheses in the parts list.

Example) IC 301 is on the point (face A, 91 of x-axis, and 111 of y-axis) of the corresponding PC board.

IC 301 (A, 91, 111) IC NJM2068V

Mark No.	Description	Part No.	Mark No.	Description	Part No.
LIST OF ASSEMBLIES					
	1..SERVICE MAIN ASSY	VXX3328	IC 8031		TC74VHC157FTS1
NSP	2..MAIN ASSY (BDP2.0)	VWV2375	IC 8101		LMH6658MMX
	2..ATAB ASSY (BDP2.0)	VWV2360	Q 4001,4004,5232		2SA1576A
			Q 4002,4003,5202		DTC124EUA
NSP	1..FLKB ASSY	VWM2481	Q 5201		UMB1N
	2..FLKY ASSY	VWG2625	Q 5211,5221		UMGK1N
	2..PSWB ASSY	VWG2613	Q 5231		HN1C03FU
			Q 6501-6505,8181		2SA1576A
NSP	1..AUJB ASSY	VWG2632	Q 8171		2SC4081
Δ	1..SYPS ASSY	VWR1415	Δ Q 8801		2SC5712
			Q 8812		UMD2N
			D 4001,4002		1SS355
	1..DRIVE ASSY BDY-103	VXX3325	D 4351,6001-6004		RB501V-40
			D 8801		UDZS7R5(B)

Mark No.	Description	Part No.	MISCELLANEOUS	
A MAIN ASSY (BDP2.0)			L 3801,3802,3814,8901	INDUCTOR CTF1384
SEMICONDUCTORS			L 4402-4406,4412-4417	INDUCTOR CTF1306
	IC 1001	R8A34019BG-RF4Z	L 4407,4408,4410,4411	INDUCTOR CTF1394
	IC 2101,2201,2301,2401	EDE5108AJBG-6E-E	L 4421,5051,5052,5061	INDUCTOR CTF1394
Δ	IC 2151,2351,3151,5301	S-1170B18UC-OTD	L 5062,5105,6001,6301	INDUCTOR CTF1394
Δ	IC 2601,3301	LP2996M	L 5106-5109	INDUCTOR CTF1306
	IC 3101,3201	EDE5116AJBG-6E-E	L 5401	INDUCTOR CTF1357
			F 1401,1421,1431,2101	EMI FILTER DTL1106
			F 2301,3101,3201,3501	EMI FILTER DTL1106
			F 3701,3801	EMI FILTER DTL1106
	IC 3501	VYW2414	F 4001,5001-5003,8001	EMI FILTER VTL1171
	IC 3551,4351	TC7SH08FUS1	F 5007-5010	EMI FILTER ATF1209
	IC 3801	PDJ015A	JA 3701	SDCARD SLOTCONNECTOR DKP3748
	IC 4001	PDC178A8	JA 4351	JACK RKN1004
	IC 4002	BD45282G	JA 5001	HDMI CONNECTOR AKP7220
Δ	IC 4101,7301,7311	S-1170B33UC-OTS	JA 6001	COMB.JACK(S+1P) AKB7146
	IC 4201	BU4809F	JA 6002	JACK VKB1165
	IC 5001	SIH9134CTU	JA 8001	JACK BOARD VKX1024
Δ	IC 5311	S-L2980A33MC-C6S	X 3801	CRYSTAL RESONATOR (27 MHz) VSS1226
Δ	IC 5321	NJM2370U1-05	X 4001	CERAMIC RESONATOR (12 MHz) VSS1216
			CN 1501	CONNECTOR VKN2050
	IC 5401,8001	ICS571MLF	CN 1601	11P CONNECTOR RKN1052
	IC 6001	NJM2566AV	CN 4401	30P CONNECTOR VKN1620
Δ	IC 7101	TPS74901KTW	CN 7001	CONNECTOR AKM1284
Δ	IC 7201	S-1170B18UC-OTD	CN 7002	CONNECTOR AKM1282
Δ	IC 7421	S-1170B50UC-OUJ	CN 8801	CONNECTOR AKM1273
Δ	IC 7501	S-L2980A50MC-C7J		
	IC 8011	TC7WH74FU		

Mark No.	Description	Part No.	Mark No.	Description	Part No.
CN 8901	27P CONNECTOR	VKN1617	R 6001,6007,7101,8181		RS1/16S332J
0	SD MEMORY CARD	VWX1233	R 6002,6008,7205		RS1/16S682J
			R 6003,6006,6010-6012		RS1/16SOR0J
			R 6201-6206		RS1/10S75R0F
RESISTORS					
R 1001-1004,2111,2112		RS1/16SS82R0F	R 6211-6216,7321,7601		RS1/10SOR0J
R 1105,1117,1119		RAB4CQ220J	R 6319,6320		RS1/16S392J
R 1111,1115,1183,1623		RS1/16S220J	R 6501,6505,6509,6513		RS1/16S1000F
R 1122-1124,1177		RAB4CQ220J	R 6517		RS1/16S1000F
R 1145,1146,1552-1555		RAB4CQ223J	R 7103		RS1/16S1201D
R 1166,1167		RS1/16SS1500F	R 7104		RS1/16S2701D
R 1171		RS1/16SS8200F	R 7105		RS1/16S3300D
R 1172		RS1/16SS1000F	R 7204,8051,8107,8108		RS1/16SOR0J
R 1176		RAB4CQ101J	R 7311,7421,8102		RS1/16S101J
R 1182,1184-1189,1193		RAB4CQ470J	R 7501,8001,8206		RS1/16S470J
R 1194,1211,1213,5026		RAB4CQ470J	R 7603,7651,7653,8112		RS1/10SOR0J
R 1201,3843,4352,7301		RS1/16S101J	R 8031,8035,8036,8048		RS1/16S220J
R 1214,1238,1252,1253		RAB4CQ103J	R 8101		RN1/16SE2201D
R 1251,2154,2354,3154		RS1/16SOR0J	R 8103		RN1/16SE6800D
R 1302,1327,1328		RAB4CQ330J	R 8104		RS1/16S331J
R 1332,1335		RAB4CQ472J	R 8105		RS1/16S152J
R 1401,1441-1445,1591		RS1/10SOR0J	R 8106		RN1/10SC75R0D
R 1502-1505,1513		RAB4CQ330J	R 8111		RS1/16S103J
R 1601,1602,1605,1606		RS1/16S221J	R 8121,8131,8132,8811		RS1/16SOR0J
R 1610,1611,1622,1651		RS1/16S221J	R 8171,8182		RS1/16S122J
R 1652,4351,4353		RS1/16S221J	R 8172		RS1/16S222J
R 2211,2212,2311,2312		RS1/16SS82R0F	R 8815		RS1/16S561J
R 2411,2412,3111,3112		RS1/16SS82R0F	R 8816,8921		RS1/10SOR0J
R 2615-2619,3303-3308		RAB4CQ220J	R 8821,8905-8910		RS1/16SOR0J
R 2637-2641,3341-3346		RAB4CQ750J	R 8901-8903,8924		RS1/16S470J
R 3211,3212		RS1/16SS82R0F	Other Resistors		RS1/16SS###J
R 3513,3833,4061,4317		RS1/16SOR0J	CAPACITORS		
R 3591-3594,3791,3792		RAB4CQ103J	C 1001,1003,1005,1006		VCG1063
R 3803,3804,3817,3819		RS1/16S220J	C 1002,1007,1010,1011		CKSSYF104Z16
R 3805,3806,4015,4016		RS1/16S103J	C 1004,1009,1016,1019		CKSRYP105Z10
R 3815,8002		RS1/16S330J	C 1008,1012,1013,1015		VCG1063
R 4017,4019,5234,5235		RS1/16S472J	C 1014,1018,1021,1029		CKSSYF104Z16
R 4024,8813		RS1/16S471J	C 1017,1020,1022,1024		VCG1063
R 4063		RAB4CQ223J	C 1023,1026,1031,1041		CKSRYP105Z10
R 4071		RS1/16S223J	C 1025,1027,1028,1030		VCG1063
R 4072,4316		RS1/16S104J	C 1032,1035-1037,1039		CKSSYF104Z16
R 4241,4355,7102,7206		RS1/16S103J	C 1033,1034,1038,1040		VCG1063
R 4354		RS1/16S224J	C 1042,1044,1046,1048		VCG1063
R 4583,4585,4591,4593		RAB4CQ103J	C 1043,1045,1049,1050		CKSSYF104Z16
R 4602,5015,5033,5034		RS1/16SOR0J	C 1047,1062,1066,1068		CKSRYP105Z10
R 5019,5030,5031,5043		RAB4CQ103J	C 1051-1053,1055-1058		VCG1063
R 5022,5023,5039		RS1/16S220J	C 1054,1064,1070,1082		CKSSYF104Z16
R 5035		RS1/16S180J	C 1061,1063,1065,1067		VCG1063
R 5036		RS1/16S6800F	C 1069,1071,1081,1084		VCG1063
R 5041,5044,5045		RAB4CQ220J	C 1072,1083,1301,1403		CKSRYP105Z10
R 5049-5052,8004-8006		RS1/16S220J	C 1085,1087,1089,1090		CKSSYF104Z16
R 5057,5211,5321,5401		RS1/16SOR0J	C 1086,1088,1091,1161		VCG1063
R 5226,5228		RS1/16SS2201F	C 1201-1203		CCSSCH180J50
R 5227		RS1/16SS4700F	C 1204,3712,8927		CCSSCH100D50
R 5231		RS1/16S473J	C 1209,1211,3823,3824		CCSRCH180J50
R 5232,8015		RS1/16S102J	C 1401,1441,2202,2302		VCH1234
R 5233,5237		RS1/16S272J	C 1404,3505,4352,4355		CKSRYP104Z50
R 5236		RS1/16S562J	C 1405,1421,1445,1448		CEVLW221M4
R 5238		RS1/16S472J	C 1406,1407,1409,1424		CGG1171
R 5405		RS1/16S22R0F	C 1408,3507,5011,5042		VCG1057
R 5406		RS1/16S62R0D			

Mark No. Description

Part No.

Mark No. Description

Part No.

	C	1422,1433,1443,1591	CKSRYP105Z10
	C	1423,1434,1444,1592	CCSRCH102J50
A	C	1431,4002,7204	VCH1269
	C	1435,1446,1447,1449	CCG1171
	C	1501,1603,1604	CCSRCH101J50
	C	1502	CCSRCH470J50
	C	1601,2103,2107,2111	CKSRYP105Z10
	C	1607-1610,1653,1654	CCSRCH101J50
	C	2102,2402,2601,2604	CEVLW221M4
	C	2104,2109,2114,2117	CKSSYP104Z16
	C	2105,2106,2108,2110	VCG1063
	C	2112,2116,2203,2207	CKSRYP105Z10
B	C	2113,2115,2205,2206	VCG1063
	C	2118,2204,2209,2214	CKSSYP104Z16
	C	2151,2152,2351,2352	CCG1171
	C	2153,2353,3153,4018	CCSRCH101J50
	C	2208,2210,2213,2215	VCG1063
	C	2211,2212,2216,2303	CKSRYP105Z10
	C	2217,2218,2304,2309	CKSSYP104Z16
	C	2305,2306,2308,2310	VCG1063
	C	2307,2311,2312,2316	CKSRYP105Z10
	C	2313,2315,2405,2406	VCG1063
	C	2314,2317,2318,2404	CKSSYP104Z16
C	C	2403,2407,2411,2412	CKSRYP105Z10
	C	2408,2410,2413,2415	VCG1063
	C	2409,2414,2417,2418	CKSSYP104Z16
	C	2416,2606,3103,3107	CKSRYP105Z10
	C	2602,3151,3152,3302	CCG1171
	C	2603,2607,3104,3109	CKSSYP104Z16
	C	2605,3305,5009,5323	CEVLW101M10
	C	2608,3105,3106,3108	VCG1063
	C	3102,3202,6001,7106	CCH1688
	C	3110,3111,3113,3116	VCG1063
	C	3112,3117,3120,3123	CKSSYP104Z16
D	C	3114,3115,3122,3203	CKSRYP105Z10
	C	3118,3119,3121,3205	VCG1063
	C	3124,3204,3209,3212	CKSSYP104Z16
	C	3206,3208,3210,3211	VCG1063
	C	3207,3214,3215,3222	CKSRYP105Z10
	C	3213,3216,3218,3219	VCG1063
	C	3217,3220,3223,3224	CKSSYP104Z16
	C	3221,3308,3503,4020	VCG1063
	C	3301,3304,3702,5002	CEVLW221M4
	C	3303,3307,4011,4021	CKSSYP104Z16
	C	3306,3504,3701,3803	CKSRYP105Z10
E	C	3501	CEVW221M4
	C	3502,3804,3862,4102	CCG1171
	C	3506,3703,3710,3711	CCSRCH102J50
	C	3802,5010,5407,7103	VCH1234
	C	3805-3808,4003,4004	CCSRCH102J50
	C	3821	CCSSCH130J50
	C	3822	CCSSCH120J50
	C	3861,4071,4601,5003	CKSRYP105Z10
	C	4012,4013,4402,4406	CCSRCH102J50
	C	4016	VCG1061
	C	4017,4019	CKSSYP103Z50
F	C	4022,4026,5014,5023	VCG1063
	C	4101,5321,5322,7422	CKSQYB225K10
	C	4201,4202,4222,4223	CKSSYP104Z16

C	4221,4356,5303,5313	CCSRCH101J50
C	4351	CCSRCH681J50
C	4401,4407,4409,4411	CKSRYP104Z50
C	4403-4405,8102	CCSRCH220J50
C	4408,7503	CEVW101M16
C	4410,4413,4416,5004	CCSRCH102J50
C	4412,6202,7001-7004	CKSRYP104Z50
C	4414,5324,7105,7107	CKSRYP105K16
C	4415	CEVW470M35
C	5006,5054,7304	CEVLW221M4
C	5007,5402	CKSRYP105Z10
C	5008,5053,5063,5066	CCSRCH102J50
C	5013,5021,5022,5045	CKSSYP104Z16
C	5041,5043,5056,5057	VCG1063
C	5044,5067,5805-5807	VCG1057
C	5046,5048-5051,5401	CKSSYP104Z16
C	5047,5052,5062,5065	CCG1171
C	5301,5302,5311,5312	CCG1171
C	5403,6002,8005,8011	VCG1063
C	5404,7005,7101,8003	CCSRCH102J50
C	5405	CCSRCH5R0C50
C	5409,5414,8926	CCSSCH101J50
C	5802-5804,5811,6018	CKSSYP104Z16
C	6003,6004,6006,6007	CCG1205
C	6011-6015,6017,7102	CCG1171
C	6201,6203-6206	CEVW102M6R3
C	6501-6505,8006,8012	VCG1057
C	7006,7007,7601,7603	CKSRYP104Z50
C	7008,7201,7301,7421	CEVLW101M10
C	7104,7202,7203,7302	CCG1171
C	7205	CKSRYP105K16
C	7303,7311,7312,7423	CCG1171
C	7305,7314,7425	CCSRCH101J50
C	7313	CCH1688
C	7501	CKSQYB225K10
C	7502	CCG1171
C	7602,7652,8801,8802	CEVLW470M16
C	7651,7653,8115	CKSRYP104Z50
C	8002	VCH1234
C	8004,8032,8175,8185	CCSRCH102J50
C	8031	CKSSYP104Z16
C	8101	CCSRCH820J50
C	8104,8901,8903,8905	CKSRYP104K50
C	8111	VCH1241
C	8117,8922-8924,8932	VCG1063
C	8171-8173,8181-8183	CKSRYP104Z50
C	8174,8184	VCH1267
C	8803-8805	CKSRYP104Z50
C	8906,8908	CCSQCH101J50
C	8907	CKSRYP104K50
C	8921	CEVLW101M10
C	8928-8931	CCSSCH101J50
C	8933	VCG1063

ATAB ASSY (BDP2.0)

MISCELLANEOUS

CN 9001 40P CONNECTOR	VKN1818
CN 9003 40P ATA CONECTOR	VKN1816

Mark No. Description**B FLKY ASSY****SEMICONDUCTORS**

IC 1
IC 2
△ Q 1,2
Q 3,4,6,9
D 1

D 2
D 3,4,9
D 10

MISCELLANEOUS

KN 1 FL HOLDER (FE)
V 1 FLUORESCENT TUBE
S 1-7 SWITCH
CN 1 30P CONNECTOR
CN 3 5P CONNECTOR

RESISTORS

R 6,73,107
R 8,71
R 21,72
R 31,35,42,67
R 37

R 52,53,74-77
R 68
R 81-84,89-94
R 95,96,100,101
Other Resistors

CAPACITORS

C 2,12,31
C 3,8,9,11
C 6
C 7,13,16,37
C 10,26

C 14,15,21,24
C 17,23,33,34
C 18
C 28
C 30,47

C 35,38,50-52
C 45,53
C 54,55
C 59,60,62,65

C PSWB ASSY**SEMICONDUCTORS**

Q 991
D 991

MISCELLANEOUS

S 991 SWITCH
CN 991 5P CONNECTOR

RESISTORS

All Resistors

CAPACITORS

C 991
C 992,995

Part No.

RPM7140-H4
PDC182A
2SA2060
DTC124EUA
UDZS2R0(B)

UDZS3R3(B)
SLR-343VC(NPQ)
SLR343BC4T(JKLM)

VNF1142
VAW1094
VSG1024
VKN1290
VKN1236

CTF1394
RS1/10S123J
RS1/10S822J
RS1/10S222J
RS1/4SA0R0J

RS1/4SA561J
RS1/10S222J
RS1/4SA561J
RS1/4SA222J
RS1/16S###J

CKSRYB105K16
CKSRYB104K50
CEAT101M16
CEAL100M50
CEAL101M16

CKSRYB104K50
CKSRYB102K50
CEJQNP220M25
CKSYB105K16
CKSYB104K25

CKSRYB104K50
CKSRYB102K50
CKSRYB104K50
CCSRCH101J50

DTC124EUA
SLR343BC4T(JKLM)

VSG1024
VKN1236

RS1/10S###J

CCSRCH101J50
CKSRYB104K50

Mark No. Description

C 993
C 994

D AUJB ASSY**SEMICONDUCTORS**

IC 1-3
△ IC 5
IC 6,7,14,15
IC 8-13,16-21
Q 1,2,11,12

Q 3,4,13,14
Q 5-10,15-18
D 3,4

MISCELLANEOUS

L 1-4 CHIP BEADS
JA 1,2 JACK
JA 3 JACK
JA 4 JACK
KN 3,4 SCREW PLATE

CN 1 27P CONNECTOR

RESISTORS

R 1,2,23-25
R 3
R 4,5,10-12
R 15,28,29
R 54-61,160-167

R 62,63,168,169
R 64-79,170-185
R 80-83
R 84,85,186,187
R 86-89,188-191

R 90-97,192-199
R 98,99,200,201
R 100-107,202-209
R 108-115,210-217
Other Resistors

CAPACITORS

C 5,9,15-18
C 6,10,137,138
C 7,8,23,40
C 11-13,55,56
C 14,30-33

C 21
C 26,27,123,124
C 28,29,34,37
C 35,38,132,135
C 41

C 42
C 43-48,51,52
C 49,50,53,54
C 57-64,153-160
C 65-80,161-176

C 89-96,109-112
C 97-104,193-200
C 113-116,209-212
C 125,126,131,134
C 127-130

CKSRYB105K16
CEJQ100M25

TC7SHU04FUS1
NJM78M05FA
WM8740SEDS
NJM5532MD
2SC4081

2SA1576A
2SD2114K
1SS355

DTF1070
VKB1159
VKB1130
VKB1265
VNE1948

VKN1617

RS1/16S470J
RS1/16S101J
RS1/10S0R0J
RS1/16S0R0J
RS1/16S1002D

RS1/16S472J
RS1/16S4300D
RS1/16S0R0J
RS1/16S332J
RS1/16S6800D

RS1/16S1500D
RS1/16S103J
RN1/16SE1301D
RN1/16SE1001D
RS1/16S###J

CKSRYB104K50
CEHAZL101M25
CEHAZA101M16
CKSSYB102K50
CKSSYB103K16

CEHAZL471M16
VCH1249
CKSRYB104K50
CKSSYB331K50
CEHAZA101M16

CEAT470M16
CKSRYB104K50
CEHAZL100M50
CEAT100M50
VCE1053

VCH1247
CCSSCH220J50
CEANP470M25
CKSRYB104K50
CKSSYB103K16

Mark No. Description

Part No.

C 139-144,147,148
 C 145,146,149,150
 C 151,152,220
 C 185-192,205-208
 C 221

CKSRYB104K50
 CEHAZL100M50
 CKSSYB102K50
 VCH1247
 CKSRYB105K16

A



SYPS ASSY has no service part.

B

■

C

■

D

■

E

■

F