

6

5

4

3

2

1

REVISION RECORD			
LTR	ECO NO:	APPROVED:	DATE:

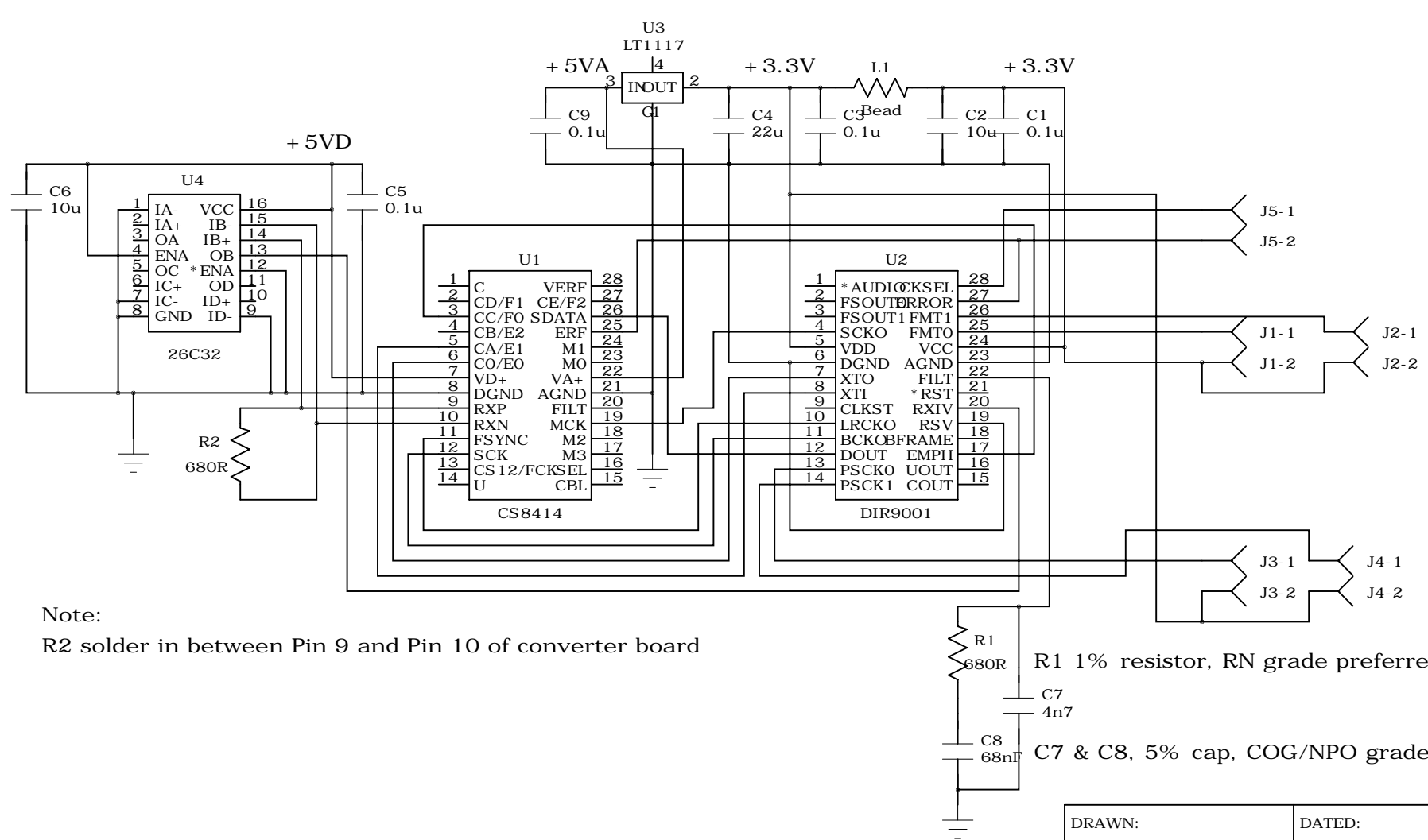

Jumper selection:

Default Open - PLL mode
Clk Select: Short-Auto; Open-PLL

Output Bit Select
J1 = FMT0, J2 = FMT1
16bit output: J1 and J2 both Open
24 Bit output: J1 short and J2 open
24bit I2S: J1 & J2 both short
SHORT = "H", OPEN = "L"

Output Freq Select
J3 = PSCK0, J4 = PSCK1
256Fs: J3 Short, J4 open
SHORT = "H", OPEN = "L"

Note:
R2 solder in between Pin 9 and Pin 10 of converter board

R1 1% resistor, RN grade preferred

C7 & C8, 5% cap, COG/NPO grade

COMPANY:

TITLE:
DIR9001 to CS8412

DRAWN:	DATED:
CHECKED:	DATED:
QUALITY CONTROL:	DATED:
RELEASED:	DATED:

CODE:	SIZE:	DRAWING NO:	REV:
SCALE:			SHEET: OF

D

D

C

C

B

B

A

A